

Canadian Best Practice Guidelines for the Prevention and Management of Pressure Ulcers in People with Spinal Cord Injury

A Resource Handbook for Clinicians

February 2013

DISCLAIMER

Limitations and Appropriate Use of the Best Practice Guidelines

- The Best Practice Guidelines are for educational and informational purposes only.
- The Best Practice Guidelines are not intended to be a fixed protocol or to dictate an exclusive course of treatment or procedure to be followed. The Best Practice Guidelines should not be considered inclusive of all proper approaches or methods, or exclusive of other acceptable approaches or methods of care.
- The Best Practice Guidelines are provided to facilitate a healthcare professional's decisions about healthcare for specific clinical scenarios. These recommendations may not be pertinent for use in all situations. The Best Practice Guidelines cannot guarantee a successful outcome and do not establish a standard of care.
- The decision to implement any particular recommendation presented in the Best Practice Guidelines must be made by a healthcare professional based on the healthcare professional's independent medical judgement, considering available resources and the situation and clinical data presented by the individual patient. Nothing contained in the Best Practice Guidelines is to be considered medical advice for specific situations nor as a substitute for the advice or professional judgement of a healthcare professional.
- Neither the authors of the Best Practice Guidelines (the "Authors"), the Ontario Neurotrauma Foundation ("ONF") nor the Rick Hansen Institute ("RHI"), Western University (Western), Lawson Health Research Institute ("LHRI") makes any representation, warranty, condition or guarantee, and hereby expressly disclaims any such representation, warranty, condition or guarantee, express or implied, statutory or otherwise, with respect to the reliability, preciseness, completeness, accuracy, clinical efficacy or effectiveness of the Best Practice Guidelines or the studies referenced in the Best Practice Guidelines.
- The Best Practice Guidelines were developed using information available prior to the time of publication. As research and technical knowledge in this field change, the present recommendations in the Best Practice Guidelines are subject to change and may be incorrect or incompatible with the current knowledge or future research in this field. It is incumbent upon the healthcare professional to stay current and maintain a current working knowledge of all advances in this field.
- Generic names of products are provided. The Best Practice Guidelines do not endorse the use of any specific products, procedures, manufacturers, services or companies.
- The Authors, LHRI, Western, ONF and RHI make no representation, warranty, condition or guarantee, and hereby expressly disclaim any such representation, warranty, condition or guarantee, whether express or implied, statutory or otherwise, with respect to the Best Practice Guidelines and the information it provides, including any representation, warranty, condition or guarantee regarding merchantability and fitness for a particular use or purpose.
- The Authors, LHRI, Western, ONF and RHI shall not be liable for any direct, special, consequential, incidental or indirect damages, liabilities, losses, costs (including legal fees and disbursements), expenses, claims, fines, penalties, demands, suits, actions, proceedings or judgments, howsoever caused, on any theory of liability, in any way related to the Best Practice Guidelines or the use of the information contained in the Best Practice Guidelines.

To obtain a printed copy of this publication, please contact:
Katika Integrated Communications Inc.
240 Brunel Rd. Mississauga ON Canada L4Z 1T5
905.949.1020, 1.866.741.5807
info@katika.com www.katika.com

This publication is also available online in HTML at:
www.onf.org

ISBN 978-0-9919094-0-7

This publication is intended to be used widely, reproduction of the resource is encouraged.

© Copyright 2013

Foreword

In 2009 a panel of experts was convened by the Rick Hansen Institute to develop a research agenda for the prevention and management of pressure ulcers in people with spinal cord injury. The panel's very first recommendation was to establish a set of evidence-informed best practice guidelines for pressure ulcer care. The intent of the new clinical practice guidelines was to build upon previous work by incorporating more current evidence and, while making them specific to the Canadian context, to also make them generally applicable to a more global audience. Thus, the mandate included revisiting many of the traditional domains of practice but also establishing guidelines on the use of telerehabilitation to meet the needs of patients in geographically remote locations. Similarly, new material on self-management was encouraged reflecting the priority given to self-actualization for individuals with spinal cord injuries. It was anticipated that these guidelines would not only inform practice and policy but also help identify gaps in knowledge to inform a research agenda.

With funding and leadership from the Rick Hansen Institute and the Ontario Neurotrauma Foundation, a panel of authorities from different disciplines set about the task of developing these Guidelines, using state-of-the-art process, including extensive external consultation and stakeholder feedback. The group worked diligently under the skilled leadership of Drs Pamela Houghton and Karen Campbell and are to be gratefully recognized for their expertise, time commitment, and the comprehensive and well documented Guidelines that have been produced.

I have no doubt these Guidelines will prove to be an invaluable resource to clinicians in many settings providing current, evidence-based, direction as to how best prevent and manage this far too common medical complication of spinal cord injury.

A handwritten signature in black ink that reads "Keith C Hayes". The signature is written in a cursive style with a large, stylized 'K' and 'H'.

Keith C Hayes PhD
Ontario Neurotrauma Foundation

Preface

Pressure ulcers are one of the most common complications affecting people living with spinal cord injury (SCI). Recent surveys suggest that the majority of people with SCI will have at least one pressure ulcer at some time point post SCI injury. The impact on the quality of life of people who develop a pressure ulcer is substantial. This is especially true for sitting acquired pressure ulcers since they significantly interfere with an individual's ability to participate in daily activities and occupation. Some people with SCI have described the experience of a pressure ulcer as impactful on their lifestyle as was the original spinal cord injury. There is a tremendous need to improve the care of these largely preventable complications so that fewer people are affected and those who are affected are impacted for the shortest time possible.

It is with great pleasure that we present to you the first ever Canadian based Best Practice Guideline for people with pressure ulcers and spinal cord injury (SCI). This publication represents the culmination of over two years work and the effort of many people. It came out of an identified need for a resource that brings together information about wound management and the care of people with SCI. Having attended national conferences and meetings of academics, clinicians, and consumers in the wound care world and more recently with those involved in the SCI community, it became evident that information about critical issues, research evidence, or clinical practices was seldom shared between individuals working in these specialized fields. Rather, each of these areas of practice (wound care and SCI rehabilitation) require a unique set of knowledge and clinical skills. Seldom does a clinician possess both sets of skills and expertise simultaneously.

We have compiled information from several existing resources including: 1) SCIRE, 2) several recently completed Best Practice Guidelines for Pressure Ulcer treatment (RNAO, CAWC and EPUAP/NPUAP) and 3) the previous document produced by the Consortium of Spinal Cord Medicine in 2000. This resource is meant to update SCI specific guidelines related to pressure ulcers, to identify areas of in existing guidelines in wound care that can be applied to people with SCI, and where we felt the situation was unique for people with SCI, we have written new sections. In the new sections, we have taken the research evidence that was collated in SCIRE and added practices that are more empirically-based. Collectively we hope this provides a very comprehensive approach to skin and wound care for the SCI population and will ultimately help prevent and better manage pressure ulcers in this group of individuals.

The collation of the information provides one of the first comprehensive resources that serves a need for all professionals working with people who have pressure sores and SCI. This resulted in a much larger resource than anticipated and there was even more that could have been included. We hope we have captured the views of the many different health care professions and several hundred individuals who reviewed this document. There should be something for everyone working in this area.

We hope this resource will support clinicians who choose to introduce best practices into their local practice setting. We recommend you select a section or a few recommendations (preferably the ones with higher level of research evidence) and tailor them to your local setting for implementation.

Good Luck

Sincerely

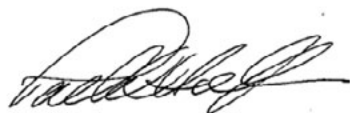

Pamela Houghton, PT, PhD

and



Karen E. Campbell, RN, MScN, PhD

Panel Members

Project leaders

Pamela Houghton, PT, PhD

Professor, School of Physical Therapy
Faculty of Health Sciences
Western University
London, ON

Karen Campbell, RN, MScN, PhD,

School of Physical Therapy
Western University
Wound Care Project Manager
Aging, Rehabilitation & Geriatric Care Research Ctr
Lawson Health Research Institute
St. Joseph's Health Care London
London, ON

Expert panel and major contributors

Susan Andrews, BSN, CWOCN

Westminster, BC

Peter Athanasopoulos

SCI Network and Service Manager,
Canadian Paraplegic Association Ontario
Toronto, ON

Jennifer Birt, OT Reg(MB)

Rehabilitation Day Program
Specialized Seating Services
Health Sciences Centre
Rehabilitation Hospital
Winnipeg, MBa

Alba Casalino, BScPT Physiotherapist

Spinal Cord Injury Rehabilitation
Parkwood Hospital
London, Ontario

Lincoln D'Souza, RN, BScN, Med

Senior Advisor and Manager, Wound and
Stoma Program
McGill University Health Centre
Montreal, QCO

Martin Ferguson-Pell, PhD

Dean, Faculty of Rehabilitation Medicine
University of Alberta
Edmonton, Alberta

Chris Fraser, HBSc, RD

Spinal Cord Injury and
Acquired Brain Injury Rehabilitation
Parkwood Hospital
London, ON

David Keast, BSc, MSc, MD, FCFPc

Director, Aging, Rehabilitation &
Geriatric Care Ctr
Lawson Health Research Institute
Medical Director
Wound Management Clinic
Parkwood Hospital
London, ON

James Mahoney, MD

Medical Director, Wound Care Program &
Perioperative Services
St. Michael's Hospital
Professor of Surgery
University of Toronto,
Toronto, ON

**Mary Ann Regan RN,
BScN, CNN (c), CRN (c),**

Spinal Cord Injury Rehabilitation,
Parkwood Hospital, London, ON

Laura Titus, BScOT, PhD (cand)

Health & Rehabilitation Sciences
Graduate Program
Western University
London, ON

**Scott Worley, MD, BScPT, FRCPC,
CSCN Diplomate (EMG)**

Physical Medicine & Rehabilitation
Stan Cassidy Centre for Rehabilitation
Fredericton, NB

Acknowledgements

The co-leads Drs Houghton and Campbell are employees of Western University and Lawson Health Research Institute. We are grateful for the infrastructure and salary support provided throughout this project.



The authors wish to thank each of the panel members (on previous page) who in addition to giving up a weekend for the consensus meeting, they spent countless hours reading articles, attending teleconference meetings, or reviewing and re writing drafts of the document. The thought put into designing the content was outstanding and the integrity with which you prepared the document was phenomenal. Thank you for all your hard work.

Joanna Gorski was the medical writer for this document. She stuck with the project to the end even though the document ended up being 90,000 words instead of 18,000. Her experience writing guidelines was invaluable and creating a document that was laid out ready for production. Thank you for your patience and for being willing to incorporate the points of view of the panel members (and there were several at times). Good advice to “let it go” when the document was ready for production.

Tom Pridding, produced all the diagrams included in the document. Thank you Tom for your prompt and very accommodating service.

Gerry Jenkinson was the copy editor on the final document. Thank you for your accurate review of the document. .

There were several undergraduate students from Western University who conducted research placements or summer student opportunities. This involved conducting literature searches, retrieving articles, making summary tables, and sending out packages to reviewers

Thank you to the following students:

Anabela Ribeiro Lopes	Hoden Ismail
Caitlin Shaw	Jennifer Brock
Jillian Struyf	Tylir Wisdom
Sandy Girgis	Jessica Seibert

The authors are grateful for the grant support provided by the Ontario Neurotrauma Foundation and the Rick Hansen Institute.



Stakeholders

The following people provided their names and credentials at the time that they submitted their review of the document. The authors also wish to thank reviewers who provided their helpful comments and did not identify themselves.

Anna Kras-Dupuis, RN	Diane Leber, RN
Brenlee Mogul-Rotman	Carly Rivers, PhD
Carol Scovil, PhD	Isabelle Robidoux, pht
Carole Neufeldt, RN, BN, CRN(c)	Marie-Therese Laramee, pht, MSc
Manouche Casimir	Eleanor Bardget, RN, ET, MCISc(WH)
Chris Murphy, RN, ET, MCISc(WH)	Eisha Watanabe, OT Reg. (MB)
Cathy Craven, MD	Ethne Nussbaum, PT, PhD
Deirdre O'Sullivan - Drombolis	Heather Flett, MSc, BScPT, BA
Janet L Brown, PT, Med	Joanne Yip, BSR, OT Reg (BC)
Marilyn Humphrey, PT	Joyce Black, PhD, RN, CWCN, FAAN
James Middleton, MBBS, PhD, FAFRM(RACP), FACRM	James Mulligan, MD
Jennifer Smith, RD	Laura Teague, RN, MN, NP-Adult
Janet Hunt, RD	Laurie Goodman, RN, BA, MHScN
Janet Kuhnke, RN	Lynne MacGregor, MD
Jennifer Holmes, OT Reg. (Ont)	Mary Mark, RN, MCISc(WH)
Laurie Rappl, PT, DPT, CWS	Colleen McGuillvray, MD
Lisa Malenfant, OT Reg (MB)	Morty Eisenberg, MD
Louise Kelly	Nancy Parslow, RN, ET, MCISc(WH)
Lyndsay Orr, BScPT, MCISc(WH)	Patrick Potter, MD
Rudy Neibuhr, BMR, PT	Shawn Brewer, RD
Susan Crawford, RD	Toba Miller, RN, MScN, MHA, GNC(c), ET
Sarah McDonald, MScOT, OT Reg (Ont.)	

Guideline Development Process

PROJECT RATIONALE

In Canada, clinical practice guidelines (CPGs) for the assessment, prevention, and treatment of pressure ulcers have been developed by the Registered Nurses' Association of Ontario (RNAO) in collaboration with the Canadian Association of Wound Care (CAWC).⁽¹⁻³⁾ The National Pressure Ulcer Advisory Panel (NPUAP) in the United States (US), and the European Pressure Ulcer Advisory Panel (EPUAP), representing many countries throughout Europe, collaborated on an international consensus that outlines recommended practices for pressure ulcer assessment, prevention, and treatment.⁽⁴⁾ Effective implementation of these guidelines has been shown to improve patient outcomes.⁽⁵⁾ These guidelines, however, do not consider the unique needs of the spinal cord injury population and are not helpful to rehabilitation clinicians.

In 2000, the Consortium of Spinal Cord Medicine produced guidelines for the assessment, prevention, and treatment of pressure ulcers. These guidelines were tailored to the specific needs of the spinal cord injury population with pressure ulcers. Separate documents meet the needs of clinicians and consumers, and both are distributed by the Paralyzed Veterans Association (PVA) in the US in hardcopy and electronic formats.⁽²²⁾ ⁽⁶⁾ Most spinal cord injury rehabilitation clinicians are aware of these guidelines, but regional differences and local needs are key barriers that have been demonstrated to limit the adoption of international CPGs.⁽⁵⁵⁾⁽⁷⁾

A need exists for Canadian guidelines reflecting the unique situation in the publically funded, universally available Canadian healthcare system and for updated guidelines considering research evidence published in the past 10 years. In addition, the physical and human geography of Canada and the concentration of healthcare providers in larger urban centres present complex challenges to equitable healthcare delivery. The evolution of the Canadian healthcare system to meet these challenges has increased the importance of certain approaches, such as self-management and telehealth, which are incorporated into this guideline.

Within Canada, a concerted effort to collect and critically appraise current research literature related to practices and treatments provided to people with spinal cord injury resulted in an important resource that is regularly updated: Spinal Cord Injury Rehabilitation Evidence (SCIRE).⁽⁵⁶⁾⁽⁸⁾ SCIRE addresses many topics important in spinal cord injury, including pressure ulcers, and provides an excellent overview of current research, but it does not deal with many empiric practices used in spinal cord injury and wound care. The management of pressure ulcers requires a comprehensive approach to all aspects of care that brings together interprofessional team members who address multifactorial issues, consider the social and environmental context, and provide an individualized and effective prevention program and treatment plan. This guideline uses and references relevant information in other guidelines that is applicable to the spinal cord injury population and uses research summaries provided in SCIRE to support recommended practices when evidence is available.



Effective prevention and management of pressure ulcers in people with spinal cord injury relies on expertise in both wound care and spinal cord injury

In Canada, this level of expertise is rarely present in the same individual, and few interprofessional clinics exist to address the multiple issues involved in the task. Furthermore, important differences between people with spinal cord injury and the general population have a substantial impact on pressure ulcer risk and management.

This guideline aims to provide experts in spinal cord injury with the wound care information they require and wound care experts with the spinal cord injury information they need to deal effectively with this

special population. One important objective of this guideline is to provide a common framework for spinal cord experts and wound care specialists that can improve communication between these groups. Improved communication can enhance pressure ulcer prevention and management strategies across the continuum of care for people with spinal cord injury, improving their quality of life and generating healthcare savings.

BEST PRACTICES IMPLEMENTATION

The Rick Hansen Institute has a national goal of standardized best practices implementation for key conditions in spinal cord injury, including pressure ulcer. The Ontario Neurotrauma Foundation and the Rick Hansen Institute are coordinating best practices implementation in spinal cord injury for Ontario and Quebec that includes achieving the following objectives:

- Establishing collaborative networks to identify and validate best practices
- Promoting the adoption and use of best practices

INTERPROFESSIONAL EXPERT PANEL

As part of its commitment to achieving these objectives, the Rick Hansen Spinal Cord Injury Solutions Network funded the development of this guideline. The guideline steering committee:

- Developed the framework, process, and scope of the proposed Canadian guidelines
- Identified Canadian experts in the relevant disciplines
- Invited them to join an interprofessional Canadian expert panel and participate in a consensus conference

The panel included representatives from consumer advocacy, nursing, physiotherapy, occupational therapy, dietetics, rehabilitation engineering, medicine (experts in wound care, physical medicine, and rehabilitation), surgery, and the Spinal Cord Injury Network. The panel was responsible for reviewing the spinal cord injury-specific guidelines and the new literature and identifying any guidelines that should be updated or revised to reflect the Canadian context. To facilitate this process, the panel was divided into working groups, according to areas of expertise and guideline topic. Before the consensus conference, the working group members individually reviewed the assigned guideline topics and the corresponding papers. After the group work, a group member presented recommendations to the entire panel to solicit input from and encourage discussion with other specialty areas, adding an interprofessional perspective to the research evaluation process.

LITERATURE SEARCH

The steering committee developed a literature search strategy with the assistance of a medical librarian (Appendix 1A). The CINAHL, Embase, PubMed, Scopus, and Cochrane databases were searched for relevant new literature to identify additional research relevant to the area and not represented in SCIRE. Papers reviewed in the Consortium for Spinal Cord Medicine Clinical Practice Guidelines (2001) or SCIRE Version 2.0 (2008) were excluded from the review list.⁽⁵⁶⁾⁽⁸⁾ The updated SCIRE recommendations were, however, reviewed at the meeting.



Published articles were included in the review list for the new guideline if they described well-designed trials with a study population that included a population of at least 50% with spinal cord injury.

Well-designed trials were defined as prospective trials in which results of the intervention were compared with an appropriate control group. Only research papers and systematic reviews or meta-analyses were included. The search identified an initial list of 520 articles. These were divided into topic areas, each of which was associated with specific guideline topics. Panel members were encouraged to submit additional articles relevant to their topics.

CONSENSUS CONFERENCE AND GUIDELINE PROCESS

Consensus Meeting of Panel Members

The interprofessional Canadian expert panel met for a consensus conference in Toronto, Ontario, October 23–25, 2010, to continue the guideline development process. At the conference, working groups first met separately to discuss recommendations for new guidelines and to reach a consensus on the wording of each guideline and the level of evidence, using the RNAO grading system (Table 1).^{(51,52)(1,2)} Where no spinal cord injury–specific research was identified, the recommendation was based on existing pressure ulcer guidelines such as those prepared by the RNAO,^{(51,52)(1,2)} the CAWC,⁽⁵³⁾⁽³⁾ NPUAP and EPUAP,⁽²³⁾⁽⁴⁾ and expert opinion.

Table 1. RNAO Levels of Evidence

Ia	Evidence from meta-analysis or systematic review of randomized controlled trials
Ib	Evidence from at least one randomized controlled trial
IIa	Evidence from at least one well-designed controlled study without randomization
IIb	Evidence from at least one other type of well-designed quasi-experimental study without randomization
III	Evidence from well-designed non-experimental descriptive studies, such as comparative, correlation, and case studies
IV	Evidence from expert committee reports or opinions and/or clinical experiences of respected authorities

The entire panel then reviewed the working group recommendations and came to a consensus on the new guidelines and supporting levels of evidence. Discussion at the meeting demonstrated the need for additional guidelines dealing with positioning and support surfaces over a full 24-hour day; the steering committee formed a task force to address these topics in more depth. The group also agreed that additional information should be provided to promote the development of dual expertise among Canadian clinicians. The panel provided input on organization, format, and content of the guideline document. The manuscript was drafted by topic sections, which were reviewed first by the steering committee and then by the working groups. The entire expert panel then reviewed a complete revised draft. After revisions from the entire panel were

incorporated, the document was circulated to a broad group of stakeholders for external review. The document was then finalized.

Stakeholder review

A total of 131 individuals were asked to comment on the completed guideline. These individuals were selected based on recommendation of panel members and located across Canada as well as in the United States (n=6) and Australia (n=2). Fifty five individuals provided their input over a 3 month collection period. These reviewers represented 9 different health care professions as well as researchers and consumers. Thirteen to sixteen percent of respondents were nurses, physicians, physiotherapists, or occupational therapists. Nine percent of respondents (or 5 individuals) were registered dietitians. Only one SCI consumer responded to our request for feedback.

Ninety-five percent of respondents indicated that they either approved or strongly approved with the recommendations in the guideline. Suggestions provided by reviewers centered around clarifying some of the wording and terminology and condensing some of the areas that appeared repetitive. Overall the guideline was warmly received by all reviewers and they thanked the panel for the tremendous amount of work that went into the document.

Pilot testing

The guidelines will undergo pilot testing as part of an Ontario Neurotrauma Foundation knowledge mobilization project (Appendix 1B).

REFERENCES

1. Registered Nurses' Association of Ontario. Risk assessment and prevention of pressure ulcers 2002. Available at <http://www.rnao.org>. Accessed November 20, 2011.
2. Registered Nurses' Association of Ontario. Assessment and Treatment of Stage I to IV pressure ulcers 2007. Available at <http://www.rnao.org>. Accessed November 20, 2011.
3. Keast DH, Parslow N, Houghton PE, Norton L, Fraser, C. Best practice recommendations for the prevention and treatment of pressure ulcers. *Adv Skin Wound Care* 2007;20:390–405.
4. European Pressure Ulcer Advisory Panel and National Pressure Ulcer Advisory Panel. Pressure ulcer prevention: quick reference guide. Washington, DC: National Pressure Ulcer Advisory Panel; 2009. Available at http://www.epuap.org/guidelines/Final_Quick_Prevention.pdf. Accessed November 20, 2011.
5. Campbell KE, Labate T, LeMesurier A, Woodbury MG, Houghton PE. Implementation of best practice in the prevention of heel pressure ulcers in the acute orthopaedic population. *Int Wound J* 2010;7:28–40.
6. Consortium for Spinal Cord Medicine Clinical Practice Guidelines. Pressure ulcer prevention and treatment following spinal cord injury: a clinical practice guideline for health-care professionals. *J Spinal Cord Med* 2001;24(Suppl 1):S40–101.
7. Thomason SS, Evitt CP, Harrow JJ, Love L, Moore H, Mullins MA, et al. Provider's perceptions of spinal cord injury pressure ulcer guidelines. *J Spinal Cord Med* 2007;30:117–26.
8. Regan M, Teasell RW, Keast D, Mortenson WB, Aubut JL, et al. Pressure ulcers following spinal cord injury. In: Eng JJ, Teasell RW, Miller WC, Wolfe DL, Townson AF, Hsieh JTC, et al, eds. *Spinal Cord Injury Rehabilitation Evidence*, 2008. Version 2.0.

CONTENTS

FOREWORD	iii
PREFACE	iv
PANEL MEMBERS	v
ACKNOWLEDGEMENTS	vi
STAKEHOLDERS	vii
GUIDELINE DEVELOPMENT PROCESS	viii
PROJECT RATIONALE	viii
BEST PRACTICES IMPLEMENTATION	ix
INTERPROFESSIONAL EXPERT PANEL	ix
LITERATURE SEARCH	ix
CONSENSUS CONFERENCE AND GUIDELINE PROCESS	x
Consensus Meeting of Panel Members	x
Stakeholder review	xi
Pilot testing	xi
REFERENCES	xi
CONTENTS	xii
INTRODUCTION	1
CONTENTS	1
SPINAL CORD INJURY: IMPACT ON THE BODY	3
NEUROANATOMY: THE SPINE, SPINAL CORD, AND SPINAL NERVE ROOTS	3
Spinal cord injury classification and level	3
Anatomic and physiologic changes after spinal cord injury	3
Nervous system	3
<i>Autonomic dysreflexia</i>	3
Other body systems	4
<i>Effect of spinal cord injury on the skin</i>	4
PRESSURE ULCERS	5
OVERVIEW	5
PREVALENCE	5
IMPACT OF PRESSURE ULCERS ON PEOPLE WITH SPINAL CORD INJURY	6
COSTS	6
REFERENCES	7
CHAPTER 1	
PRESSURE ULCER PREVENTION AND THE INTERPROFESSIONAL TEAM	9
CONTENTS	9
INTERPROFESSIONAL TEAM	10
PRINCIPLES	10
Challenge of pressure ulcer prevention	10
Need for improved prevention and treatment	10
Interprofessional spinal cord injury teams	10
Evidence	11
INTERPROFESSIONAL TEAM ACROSS THE CONTINUUM OF CARE	11
Acute care and rehabilitation: specialized units	11
Evidence	11
Community phase: specialized outpatient or outreach services	12
Evidence	12

PRESSURE ULCER RISK FACTORS	12
PRINCIPLES	12
Definitions	12
IDENTIFICATION OF PRESSURE ULCER RISK FACTORS	13
Risk according to etiology of spinal cord injury	14
Risks associated with specific phases of care	14
Prehospital management	14
Acute care	14
Inpatient rehabilitation	15
Community phase	16
PRESSURE ULCER RISK FACTOR ASSESSMENT	18
Risk assessment tools	18
Is it worth using risk assessment scales for pressure ulcers in people with spinal cord injury?	18
Assessment of specific factors affecting risk	20
Deep Tissue Injury	20
CONCLUSIONS	21
REFERENCES	21

CHAPTER 2

HUMAN FACTORS AFFECTING PRESSURE ULCER PREVENTION

CONTENTS

SKIN CARE	25
NEUROLOGICALLY IMPAIRED SKIN	25
Maintaining skin integrity	25
CONTINUUM OF CARE	26
Pressure ulcer prevention during acute care	26
Evidence	27
Prevention during rehabilitation and the community phase	27
Skin inspection	27
Pressure-redistributing activities	29
PSYCHOSOCIAL FACTORS	29
INTERACTION BETWEEN PSYCHOSOCIAL FACTORS AND PRESSURE ULCERS	29
Psychosocial risk factors	29
Quality of life after spinal cord injury	29
Pain	30
Depression	31
Psychosocial impairment	32
Personality disorder	32
Psychosocial interventions	32
LIFESTYLE	33
RISK FACTORS, PREVENTION, AND INTERVENTIONS	33
Principles explaining pressure ulcer development	34
Clinical lifestyle intervention program	34
BELIEFS AND BEHAVIOURS	35
BELIEFS	35
Skin care beliefs	35
Pressure ulcer experience	36
BEHAVIOURS	37
Testing the theory of planned behaviour	37
Pressure ulcer prevention behaviours	37
Behavioural responses to pressure ulcer	38

EDUCATION AND BEHAVIOUR CHANGE	39
INTERVENTIONS	39
Education	39
Evidence	39
Behaviour-contingent structured education	40
Structured education and follow-up	40
Risk assessment and feedback	41
SELF-MANAGEMENT	41
CONCEPTS AND APPROACHES	41
5-A conceptual framework	42
Skin Management needs assessment checklist	42
Peer support	43
Perceptions of pressure ulcer prevention	43
Educational needs	43
SELF-MANAGEMENT PROGRAMS	44
Registered Nurses' Association of Ontario	44
British Columbia Paraplegic Association Provincial Peer Program	44
SCI-U	44
SpinalCordConnections.ca	44
Spinal Cord Injury Solutions Alliance	45
INFORMATION SOURCES FOR PEOPLE WITH SPINAL CORD INJURY	45
CONCLUSION	45
REFERENCES	46

CHAPTER 3

BODY WEIGHT, NUTRITION, AND HEMATOLOGIC AND

BIOCHEMICAL PARAMETERS OF HEALING

CONTENTS

BODY WEIGHT AND NUTRITION	51
PRINCIPLES	51
Role of nutrition in pressure ulcer risk and healing	51
Registered dietitian	51
Resources	51
Nutrition screening tools	52
NUTRITIONAL ASSESSMENT	52
Anthropomorphic measures: underweight, overweight, and obesity	52
Weight loss	53
Overweight and obesity	53
Dietary intake and losses	54
Calorie intake	54
Protein status	55
Hydration	55
Micronutrients	55
Nutrition- and hydration-related blood work	56
INTERVENTIONS	56
Nutritional management	56
Factors influencing nutritional status	56
Calories	56
Protein	57
Hydration	57

Amino acid supplementation	58
Micronutrients	58
<i>Vitamin A</i>	59
<i>Vitamin C</i>	59
<i>Vitamin E</i>	59
<i>Iron</i>	59
<i>Zinc</i>	59
Contraindications and precautions to supplementation	60
Enteral and total parenteral nutrition	60
HEMATOLOGIC AND BIOCHEMICAL PARAMETERS OF HEALING	61
RECOMMENDED BLOOD WORK	61
Evidence	61
Anemia	62
Inflammatory markers	62
Endocrine factors	63
Glucose metabolism	63
Thyroid function	63
CONCLUSIONS	64
REFERENCES	64
CHAPTER 4	
PRINCIPLES OF PRESSURE MANAGEMENT	67
CONTENTS	67
INTRODUCTION	69
GENERAL PRINCIPLES	69
CONTEXT	69
INDIVIDUALIZED APPROACH	69
INTERPROFESSIONAL TEAM	70
ASSESSMENT PRINCIPLES FOR THE 24-HOUR APPROACH	70
ASSESSMENT USING THE 24-HOUR APPROACH TO PRESSURE MANAGEMENT	70
Goal of the sitting assessment or reassessment	71
STEPS IN THE COMPREHENSIVE ASSESSMENT	71
1. Understanding the individual	72
2. Performing a physical assessment	72
3. Analyzing and interpreting the findings	73
4. Formulating a collaborative plan of action	73
CRITICAL ASSESSMENT CONSIDERATIONS	73
Positioning	73
Support surfaces	74
Mobility	74
Role of pressure mapping in pressure management	75
INTERVENTION PRINCIPLES FOR THE 24-HOUR APPROACH	75
DEVELOPING AN INTERVENTION PLAN	75
PRESSURE-REDISTRIBUTION STRATEGIES: TERMS AND DEFINITIONS	76
Pressure redistribution through functional movement	76
Active weight shifts	76
Dynamic weight shifts	76
REASSESSMENT	77
Pressure ulcer: an indication for reassessment and treatment	77

PREVENTION AND TREATMENT CONSIDERATIONS	78
Level of spinal cord injury	78
Higher cervical injuries	78
Lower cervical and upper thoracic injuries	79
Lower thoracic injuries	79
Continuum of care	79
Acute spinal cord injury phase	79
Rehabilitation phase	80
Community phase	81
Long-term spinal cord injury phase	81
CONCLUSION	82
REFERENCES	82
CHAPTER 5	
BEDS, MATTRESSES, AND RECUMBENT POSITIONING	85
CONTENTS	85
RECUMBENT POSITIONING	87
PRINCIPLES	87
Supine position	88
Preventing heel ulcers	89
Side-lying position	90
Prone position	91
Reclining position	92
Elevating the head of the bed	92
Sitting position in bed	93
INTERVENTION	94
Prevention of pressure ulcers during recumbent positioning	94
Bed repositioning	94
Prevention during acute care	95
Pressure management in individuals with a pressure ulcer	96
Avoiding sustained bed rest for pressure ulcer treatment	96
SUPPORT SURFACES	97
PRINCIPLES	97
Support surfaces for people with pressure ulcers	97
Reactive technologies	97
Active technologies	98
Selection considerations	98
Type of ulcer and goals of ulcer care	99
INTERVENTION	100
Support surface selection tools	101
Support surface selection	101
Reassessment	102
CONSIDERATIONS	103
Force and microclimate characteristics	103
Impact on function and safety	103
CONCLUSIONS	103
REFERENCES	104

CHAPTER 6

WHEELCHAIRS AND OTHER SEATING 107

CONTENTS 107

SITTING SUPPORT SURFACES INCLUDING WHEELCHAIRS 109

PRINCIPLES IN ASSESSMENT AND INTERVENTION 109

Neutral pelvic position 109

Sitting posture changes due to spinal cord injury 109

 Pelvic and trunk asymmetry 110

 Postural instability 110

 Spinal deviations 110

 Spasticity 111

Microclimate 111

 Additional layers 111

 Clothing and shoes 112

Sitting posture and positioning principles 112

 Evidence 112

Principles of support surface and equipment trial and prescription 113

SITTING ASSESSMENT 114

Goals of sitting assessment or reassessment 114

Specialized seating clinics 115

Components of a comprehensive sitting assessment 115

SITTING INTERVENTION 116

Steps in selecting an appropriate seating support surface 116

 1. Seating goals 116

 2. Seating simulation and trial 116

 4. Follow-up 117

WHEELCHAIR PRESCRIPTION 117

Impact of lifestyle and wheelchair use on wheelchair prescription 118

Wheelchair back supports 119

Wheelchair cushions 119

 Evidence 121

Dynamic weight-shifting technology for pressure redistribution 122

OTHER SEATING 124

Bathroom surfaces 124

 Commode/toilet 124

 Shower bench 125

Travel surfaces 126

 Road travel 126

 Air travel 126

Other activities and recreation 126

REASSESSMENT OF SEATING SYSTEMS 127

CONCLUSIONS 128

REFERENCES 128

CHAPTER 7

MOBILITY, ACTIVITY, AND CONDITIONING 131

CONTENTS 131

PRINCIPLES 133

 FOCUS ON THE PERSON WITH SPINAL CORD INJURY 133

Optimizing independence through training	133
Challenges to skin integrity	133
Physical conditioning	133
Role of mobility in pressure ulcer prevention	133
ASSESSMENT OF MOBILITY	134
INTERPROFESSIONAL APPROACH	134
Overview of assessment	134
Pressure ulcer risks associated with mobility and activity	135
Reassessment of mobility	136
INTERVENTION	136
GROSS MOTOR SKILLS TRAINING	136
Bed mobility	137
Repositioning in bed	138
Transitional movements	138
Transfers	138
Approaches to repositioning and transfers	140
Wheelchair skills and propulsion	140
Pressure-redistribution strategies	141
Pressure redistribution using functional movements	141
Intentional weight-shifting strategies	142
Standing	145
Walking	145
EXERCISE AND CONDITIONING	146
Health risks of inactivity	146
Exercise for pressure ulcer prevention	146
Muscle length and joint range of motion	146
Exercise and circulation	147
Focus on function	147
GLUTEAL NEUROMUSCULAR STIMULATION	147
Surface electric stimulation	147
Implanted percutaneous electrodes: a case study	148
Implanted electric stimulation system	148
CONCLUSIONS	149
REFERENCES	149

CHAPTER 8

ASSESSMENT AFTER DEVELOPMENT OF A PRESSURE ULCER	151
CONTENTS	151
PRINCIPLES	153
ASSESSMENT	153
THE INDIVIDUAL	153
Components of a comprehensive assessment	153
Re-evaluation of pressure and other forces	154
THE ULCER	155
WOUND INFECTION	156
Complications of wound infection	157
REASSESSMENT	158
EVIDENCE	159
CONCLUSIONS	159
REFERENCES	160

CHAPTER 9

PRESSURE ULCER TREATMENT	161
CONTENTS	161
PRINCIPLES	163
Interprofessional team	163
Pressure ulcer causes and contributing factors	164
Bed rest and pressure ulcer healing	164
PRESSURE MANAGEMENT	165
Need for comprehensive reassessment	165
Need for short-term rehabilitation	166
Sitting Schedules and Positioning	166
Support surfaces	166
Selection of recumbent support surfaces	166
Assessment of sitting support surfaces and equipment	167
NONSURGICAL TREATMENT	168
WOUND CARE	168
RNAO recommendations	168
Cleansing and antiseptics	169
Debridement	169
Dressings	169
Wound infection	170
ADJUNCTIVE THERAPY	170
Electrical stimulation	170
Evidence	170
Other adjunctive therapies	171
Electromagnetic energy	172
Ultraviolet-C light	172
Noncontact nonthermal acoustic pressure therapy	172
Topical oxygen	172
Maggot therapy	172
Topical recombinant growth factors	172
Recombinant human erythropoietin	173
Anabolic steroids	173
Activated factor XIII	173
Tension therapy	173
Hyperbaric oxygen	174
Adjunctive therapies not recommended for treatment of pressure ulcers in people with spinal cord injury	174
Ultrasound	174
Negative pressure wound therapy	174
Lasers	174
Topical phenytoin	174
SURGICAL TREATMENT	175
PRINCIPLES	175
Interprofessional team	175
Criteria for surgical closure of a pressure ulcer	175
PREOPERATIVE CONSIDERATIONS	177
Infection	177
Nutrition	177
Incontinence	178
Spasticity and contractures	178
Comorbidities	179

Previous pressure ulcer surgery	179
Smoking	179
Osteomyelitis	179
Urinary tract infection	180
Heterotopic ossification	180
SURGICAL PROCEDURES	180
Debridement	180
Flap surgery	181
Ischial pressure ulcer repair	182
Sacral pressure ulcer repair	182
Perineal pressure ulcer repair	183
Olecranon pressure ulcer repair	183
Repair of complex back wounds	183
Amputation and salvage surgery	184
POSTOPERATIVE MANAGEMENT	185
Surgical complications	185
CONCLUSIONS	186
REFERENCES	187
<i>CHAPTER 10</i>	
TELEREHABILITATION	191
CONTENTS	191
PERSPECTIVES ON TELEREHABILITATION	193
RELEVANT EXAMPLES	193
Wound care	193
Pressure ulcers in spinal cord injury	194
Spinal cord injury	195
CANADIAN RESEARCH INITIATIVE	195
CONCLUSIONS	195
REFERENCES	196
<i>CHAPTER 11</i>	
CONTENTS	197
APPENDIX 1:	199
GUIDELINE DEVELOPMENT PROCESS	199
A. Search Terms	199
Scopus	199
Cochrane	199
Embase & cinahl	199
Pubmed	199
B. PILOT TESTING SITES	200
Ontario Neurotrauma Foundation	200
APPENDIX 2:	201
IMPACT OF SPINAL CORD INJURY ON THE BODY	201
A. NEUROANATOMY	201
B. AMERICAN SPINAL INJURY ASSOCIATION (ASIA) IMPAIRMENT SCALE	204
C. TETRAPLEGIA AND PARAPLEGIA	204
Tetraplegia	204
Paraplegia	205
D. AUTONOMIC DYSREFLEXIA	205

E. ANATOMIC AND PHYSIOLOGIC CHANGES AFTER SPINAL CORD INJURY	206
Pain	206
Bone	206
Skeletal muscle	206
Endocrine system	206
Body weight	207
Cardiovascular system	207
Skin	207
Peripheral vascular perfusion	207
Lungs	207
Immunity	208
Aging	208
REFERENCES	208
USEFUL RESOURCES	208
APPENDIX 3:	209
NATIONAL PRESSURE ULCER ADVISORY PANEL; INTERNATIONAL PRESSURE ULCER CLASSIFICATION SYSTEM 2009	209
Stage I: Non-blanchable erythema	209
Stage II: Partial-thickness skin loss	209
Stage III: Full-thickness skin loss.	210
Stage IV: Full thickness tissue loss	210
Unstageable or unclassified	211
Suspected deep tissue injury	211
APPENDIX 4:	212
SUPPORT SURFACES	212
A. TERMS AND DEFINITIONS RELATED TO SUPPORT SURFACES 2007	212
Physical concepts related to support surfaces	212
Components of support surfaces	213
Features of support surfaces	213
Categories of support surfaces.	214
B. SUPPORT SURFACE SELECTION TOOL	214
C. REACTIVE SUPPORT SURFACE SELECTION TOOL	215
D. ACTIVE SUPPORT SURFACE SELECTION TOOL	215
APPENDIX 5:	216
GRADUATED SITTING PROTOCOL FOR PRESSURE ULCER MANAGEMENT	216
APPENDIX 6:	217
LEVINE METHOD FOR WOUND SWAB FOR CULTURE AND SENSITIVITY	217
APPENDIX 7:	218
MOBILIZATION PROTOCOL AFTER FLAP SURGERY	218
APPENDIX 8:	219
SPECIALIZED ASSESSMENT FORMS	219
A. PHYSIOTHERAPY ASSESSMENT FORM	219
B. PRESSURE MANAGEMENT ASSESSMENT TOOL	222
C. WINNIPEG HEALTH SCIENCES CENTRE	236
D: NEW SOUTH WALES STATE SPINAL CORD INJURY SERVICE, SPINAL SEATING PROFESSIONAL DEVELOPMENT PROJECT	258
RESOURCES	278
SUMMARY OF RECOMMENDATIONS	279

CONTENTS

SPINAL CORD INJURY: IMPACT ON THE BODY 3

NEUROANATOMY: THE SPINE, SPINAL CORD, AND SPINAL NERVE ROOTS 3

 Spinal cord injury classification and level 3

 Anatomic and physiologic changes after spinal cord injury 3

 Nervous system 3

Autonomic dysreflexia 3

 Other body systems 4

Effect of spinal cord injury on the skin 4

PRESSURE ULCERS 5

 OVERVIEW 5

 PREVALENCE 5

 IMPACT OF PRESSURE ULCERS ON PEOPLE WITH SPINAL CORD INJURY..... 6

 COSTS 6

REFERENCES 7

Spinal cord injury: impact on the body

NEUROANATOMY: THE SPINE, SPINAL CORD, AND SPINAL NERVE ROOTS

Understanding the implications of spinal cord injury levels relies on knowing the injury definitions, the correspondence between vertebral and spinal cord segments, and the location of the spinal nerve roots in relation to these segments (*Appendix 2A*).

For the most part, spinal cord segments do not line up with vertebral segments of the same number. For example, lumbar spinal cord segments (L1–L5) occupy the T9 to T11 vertebral space, and sacral cord segments (S1–S5) are located at the T12–L1 vertebral level.

The spinal roots of the first seven pairs of cervical nerves leave the vertebral column *proximal* to the vertebral segment of the same number, but C8 and the remaining pairs of spinal nerve roots exit distal to the corresponding vertebral body. The dorsal nerve roots carry afferent sensory fibres, whereas the ventral roots carry efferent motor fibres. Each pair of spinal nerves innervates the corresponding dermatome and myotome (*Appendix 2A*).

Spinal cord injury classification and level

The American Spinal Injury Association (ASIA) Impairment Scale is the standard for describing the degree of spinal cord injury and documenting sensory and motor impairment following spinal cord injury. ASIA is based on neurologic responses and strength in 10 key muscles on each side of the body (*Appendix 2B*).⁽¹⁾ In the more distal parts of the spine, discrepancy exists between cord and vertebral segment levels, with spinal nerve roots corresponding more closely to the vertebral than the cord segment number. For example, damage to the thoracolumbar vertebral junction primarily affects the sacral cord segments and the roots of T12. It is not the bony level of injury but the neurologic level that is relevant.

Anatomic and physiologic changes after spinal cord injury

NERVOUS SYSTEM

Changes to the nervous system are the most profound results of spinal cord injury. These include loss of muscle function that causes functional impairment of upper and/or lower extremities, known as tetraplegia and paraplegia. The level of neurologic injury affects the individual's ability to function independently and the susceptibility to pressure ulcer development.

 **APPENDIX 2C** provides a description of typical functional outcomes associated with paraplegia and tetraplegia.

AUTONOMIC DYSREFLEXIA

Autonomic dysreflexia is a serious and potentially life-threatening problem that can occur in people with spinal cord injury with neurologic level of injury at or above T5 or T6.⁽²⁾ It can also occur in individuals with incomplete injuries.

Although autonomic dysreflexia can be asymptomatic, typical signs and symptoms include a sudden blood pressure increase of up to 30 mm above baseline, reflex bradycardia, anxiety, blurred vision, headache, flushing, and sweating above the level of injury.⁽³⁾ Autonomic dysreflexia is triggered by stimuli below the level of injury, such as a pressure ulcer, and usually resolves once the stimulus is eliminated. Swift recognition and treatment

are required to relieve the inciting stimulus; treatment may include changing position, emptying the bladder or bowels, and removing or loosening tight clothing or devices, such as a leg bag holder or abdominal binder.⁽²⁾

 **APPENDIX 2D** explains the mechanisms underlying autonomic dysreflexia.

OTHER BODY SYSTEMS

Spinal cord injury also has profound anatomic and physiologic effects. Many of the structural and physiologic changes that occur after spinal injury affect homeostatic mechanisms, decreasing the body's ability to maintain skin integrity when pressure ulcer risk factors accumulate. A brief summary of the changes occurring after spinal cord injury is provided below, and changes affecting the skin and pressure ulcer susceptibility and healing are discussed in this section.

 **APPENDIX 2E** provides a more detailed description of these anatomic and physiologic changes.

- Neurologic injury affects the ability to function independently and increases the susceptibility to pressure ulcer development.
- Injury at or above T5 or T6 produces autonomic dysreflexia; the reflex sympathetic surge from the thoracolumbar sympathetic nerves causes widespread vasoconstriction and arterial hypertension that can result in stroke, seizures, heart attack, or death.
- Most people with spinal cord injury experience some type and degree of pain that is affected by the level of injury. Pressure ulcers are often associated with pain.⁽⁴⁾
- Osteoporosis, a complication of spinal cord injury, affects mostly the pelvis and legs. Fragility fracture, the most important complication of osteoporosis, is frequently seen at the supracondylar femur and the proximal tibia.⁽⁵⁾
- Muscle atrophy reduces the natural protective cushioning that muscles provide over bony areas, increasing the risk of pressure ulcer formation.⁽⁶⁾
- Muscle atrophy and inactivity after spinal cord injury change body composition, promoting development of metabolic syndrome, an important risk factor for both cardiovascular disease and diabetes.⁽⁷⁾
- Obesity is a risk factor for pressure ulcer development, and approximately two-thirds of people with spinal cord injury are obese.^(8,9)
- Cardiovascular disease has double the expected incidence among people with spinal cord injury, decreases tissue oxygenation, and may increase the risk of pressure ulcers.⁽¹⁰⁾
- Pulmonary dysfunction reduces tissue oxygenation, which is important for maintenance of tissue viability under applied pressure.
- Spinal cord injury depresses immune system function.^(11,12)
- In all body systems, spinal cord injury hastens the physical decline and functional loss associated with aging, beginning 10 to 20 years after injury.⁽¹³⁾

EFFECT OF SPINAL CORD INJURY ON THE SKIN

Denervation produces a variety of metabolic and physiologic changes affecting the skin of individuals with spinal cord injury.⁽¹⁴⁾ Rappal et al summarized the effect of spinal cord injury on the function of skin and its ability to respond to injury. Changes that occur soon after denervation affect virtually every aspect of the healing process. Persistent inflammatory signals significantly alter circulating inflammatory mediators, depress immune response, and change metabolic function.^(15,16) Vascular changes decrease the inflammatory phase of healing and reduce oxygen levels. A decrease in fibronectin reduces fibroblast activity and extracellular matrix and collagen formation, leading to a change in the type of collagen formed. Large thick bundles of type I collagen predominate in the dermis, and small elastic type III collagen fibres decrease in the epidermis.⁽¹⁷⁾ Thickened and indurated skin, which is commonly seen in people with spinal cord injury, may be related to dermal fibrosis.⁽¹⁸⁾

Several studies have documented reduced skin temperature and transcutaneous oxygen levels in the sacral region of people with spinal cord injury in comparison with age-matched controls. Cotie et al detected increased resting skin temperature and decreased skin temperature reactivity in the legs of people with spinal cord injury who were participating

in supported standing.⁽¹⁹⁾ Baseline levels of skin perfusion are further reduced with short periods of pressure loading, and the reactive hyperemia response to pressure in sacral skin blood flow is weaker.^(20,21) Prolonged pressure associated with extensive wheelchair use or bed rest has been associated with increased skin temperature and sweating in some subjects and is unrelated to pressure amount and duration. Variable and dramatic skin temperature changes in response to pressure loading indicate subcutaneous blood flow dysregulation secondary to loss of autonomic nervous system control.



Physiologic changes stemming from spinal cord injury may contribute to the difficulty in healing pressure ulcers in people with spinal cord injury.  *Additional detail about the impact of spinal cord injury on skin is found in: Consortium for Spinal Cord Medicine Clinical Practice Guidelines. Pressure ulcer prevention and treatment following spinal cord injury: a clinical practice guideline for health-care professionals. J Spinal Cord Med 2001;24(Suppl 1):S40–101*

Pressure ulcers

OVERVIEW

Pressure ulcers (also called bedsores, decubitus ulcers, and chronic pressure wounds) are defined as a localized injury to the skin and/or underlying tissue as a result of pressure, or pressure in combination with shear and/or friction.⁽²³⁾ The high wheelchair use in the population with spinal cord injury is responsible for the prevalence of seating-acquired pressure ulcers in the buttock region over the ischial tuberosities or sacrum. Pressure ulcer formation is a complex process that is still not completely understood, and recent reviews have highlighted altered pathophysiologic processes precipitating pressure ulcers in skin that has been denervated due to spinal cord injury.⁽¹⁴⁾ Many factors interact to predispose an individual to pressure-related skin breakdown.

 **APPENDIX 3** describes staging of pressure ulcers by depth and severity.

PREVALENCE

Pressure ulcers are considerably more common among people with spinal cord injury than in the general population.⁽²⁴⁾ These breaks in the skin are consistently identified as one of the most common secondary medical complications plaguing people living with spinal cord injuries.^(25,26) The annual incidence of pressure ulcers has been reported between 23 and 37%.^(27–31) According to Model Spinal Cord Injury Care Systems in the United States (US), 33% of people with spinal cord injury develop at least one pressure ulcer during initial hospitalization.^(32–33) The prevalence of pressure ulcers in those with spinal cord injury was 8% after 1 year, increasing to 9% after 2 years and 32% at 20 years post spinal cord injury.⁽³³⁾

A cohort study (n=118) by Garber et al, using interviews, questionnaires, and physical examinations 3 years apart, found pressure ulcer risk in the 12 months before each set of interviews to be just over 30%.⁽²⁷⁾ This level of self-reported pressure ulcers was much lower than the pressure ulcer prevalence rate of 59% obtained when healthcare professionals performed a full-body skin assessment. The discrepancy is likely due to the difficulty individuals have in detecting stage I pressure ulcers, which represented 27% of pressure ulcers identified by clinicians in the Garber study.⁽²⁷⁾

Chen et al suggested that even after factoring in age and other medical complication rates, pressure ulcer prevalence rates increase steadily over a 10-year period.⁽³⁴⁾ Fortunately, the majority of pressure ulcers identified in prevalence surveys are not severe (stage I or II).

Up to 95% of people with spinal cord injury will experience a pressure ulcer sometime during their lifetime.⁽³⁵⁾ A cross-sectional survey (n=218) of people with paraplegia living in Japan found 85.7% had experienced pressure ulcers and 46.3% had undergone multiple surgical procedures for ulcer treatment.⁽³⁶⁾ The complication rates of persons with spinal cord injury with pressure ulcers who have surgery is very high.⁽³⁷⁾ A study of people with spinal cord injury by Krause and Broderick reported that 17% of participants had at least one new pressure ulcer every 2 years, and 4% had pressure ulcers almost constantly.⁽³⁸⁾

IMPACT OF PRESSURE ULCERS ON PEOPLE WITH SPINAL CORD INJURY

Pressure ulcers are known to disrupt rehabilitation, prevent individuals with spinal cord injury from attending work or school, and interfere with community reintegration. The presence of a pressure ulcer can limit a person's ability to participate in meaningful activities.⁽³⁹⁾ In addition, a fear of pressure ulcers instilled at the time of rehabilitation has the potential to challenge a person's ability to experience a full and satisfying life. The reduced activity and prolonged bed rest that often accompany pressure ulcer treatment significantly affect quality of life and can lead to clinical depression.^(40,41) The occurrence of a pressure ulcer can also lead to rehospitalization, often with extended lengths of stay.⁽⁴²⁾ Although pressure ulcers are not considered life-threatening medical conditions, it should be recognized that, left untreated or poorly treated, serious complications, including septicemia, can ensue. Pressure ulcers may be the direct cause of 7 to 8% of premature deaths in people with spinal cord injury.⁽⁴³⁾

COSTS

It has been estimated that pressure ulcers account for one-quarter of the cost of care for people with spinal cord injury. Chen et al found that unhealed pressure ulcers were among the leading causes of unplanned hospitalization after spinal cord injury.⁽³⁴⁾ In Canada, Jaglal reported a 27.5% rehospitalization rate within a year of rehabilitation, with pressure ulcers identified as a primary reason for readmission.⁽⁴⁴⁾ Pressure ulcers increase length of stay (average 62.3 days) and the cost of treatment more than other medical conditions.⁽⁴²⁾

In the United Kingdom (UK), a month of treatment starts at over \$2,000 for uncomplicated early pressure ulcers and escalates to over \$12,000 for ulcers complicated by osteomyelitis.⁽⁴⁵⁾ Estimates to heal a pressure ulcer from the US range between \$5,000 and \$25,000, with a healthcare-acquired pressure ulcer adding \$10,845 to the hospital bill.^(46,47) Should surgical closure be required, in the US costs escalate to an average of \$70,000 per person.⁽⁴⁸⁾ The overall health system cost of managing pressure ulcers in Canada has not been determined, but the economic impact of this often preventable problem is substantial. Allen and Houghton, reporting on a pressure ulcer case, found that 3 months of community care cost \$27,000, with half of these costs borne by the patient.⁽⁴⁹⁾ Chan et al followed a small sample of people with spinal cord injury who were living in two Canadian urban centres and receiving home care for chronic pressure ulcers at a monthly cost of \$4,745.⁽⁵⁰⁾ Considering the longstanding nature of these pressure ulcers in this sample (average duration 3.5 years) and the fact that the treatment did not heal the wounds, the cumulative cost to treat chronic pressure ulcers in the Canadian healthcare system is likely enormous.

REFERENCES

1. SCRIRE. International standards for neurological classification of spinal cord injury. Available at: <http://www.scireproject.com/outcome-measures/american-spinal-injury-association-international-standards-neurological-classificat>. Accessed November 29, 2012.
2. Paralyzed Veterans of America/Consortium for Spinal Cord Medicine. Acute management of autonomic dysreflexia: individuals with spinal cord injury presenting to health care facilities. Washington, DC: Paralyzed Veterans of America (PVA); July, 2001. Reviewed January, 2006 and current.
3. Cragg J, Krassioukov A. Five things to know about autonomic dysreflexia. *CMAJ* 2012;184:66.
4. Ragnarsson KT, Stein AB, Spungen AM, Bauman WA. Medical complications after spinal cord injury: spasticity, pain, and endocrine/metabolic changes. *Top Spinal Cord Inj Rehabil* 2004;10:86–106.
5. Weiss D. Osteoporosis and spinal cord injury. Available at <http://www.emedicine.medscape.com/>. Accessed December 10, 2010.
6. Linder-Ganz E, Gefen A. Stress analysis coupled with damage laws to determine biomechanical risk factors for deep tissue injury during sitting. *J Biomech Eng* 2009;131:011003.
7. Scelsi R. Skeletal muscle pathology after spinal cord injury: our 20 year experience and results on skeletal muscle changes in paraplegics, related to functional rehabilitation. *Basic Appl Myol* 2001;11:75–85.
8. Gater DR. Obesity after spinal cord injury. *Phys Med Rehabil Clin N Am* 2007;18:333–51.
9. Kocina P. Body composition of spinal cord injured adults. *Sports Med* 1997;23:48–60.
10. Szlachcic Y, Carrothers L, Adkins R, Waters R. Clinical significance of abnormal electrocardiographic findings in individuals aging with spinal injury and abnormal lipid profiles. *J Spinal Cord Med* 2007;30:473–6.
11. Bauman WA, Spungen AM. Metabolic changes in persons after spinal cord injury. *Phys Med Rehabil Clin N Am* 2000;11:109–40.
12. Nash MS. Known and plausible modulators of depressed immune functions following spinal cord injuries. *J Spinal Cord Med* 2000;23:111–20.
13. Menter RR, Hudson LM. Spinal cord injury clinical outcomes. In: Stover S, ed. *The Model Systems*. New York, NY: Aspen Pubs; 1995. p. 272.
14. Rappl LM. Physiological changes in tissues denervated by spinal cord injury tissues and possible effects on wound healing. *Int Wound J* 2008;5:435–44.
15. Rebhun J, Madorsky JG, Glovsky MM. Proteins of the complement system and acute phase reactants in sera of patients with spinal cord injury. *Ann Allergy* 1991;66:335–8.
16. Cruse JM, Lewis RE, Dilioglou S, Roe DL, Wallace WF, Chen RS. Review of immune function, healing of pressure ulcers, and nutritional status in patients with spinal cord injury. *J Spinal Cord Med* 2000;23:129–35.
17. Stover SL, Gay RD, Koopman W, Sahgal V, Gale LL. Dermal fibrosis in spinal cord injury patients. A scleroderma variant? *Arthritis Rheum* 1980;23:1312–17.
18. Stover SL. Skin complications other than pressure ulcers following spinal cord injury. *Research Update Newsletter* 1993. Available at <http://www.spinalcord.uab.edu/>. Accessed December 10, 2010.
19. Cotie LM, Geurts CLM, Adams MME, MacDonald MJ. Leg skin temperature with body-weight-supported treadmill and tilt-table standing training after spinal cord injury. *Spinal Cord* 2011;49:149–53.
20. Sae-Sia W, Wipke-Tevis DD, Williams DA. The effect of clinically relevant pressure duration on sacral skin blood flow and temperature in patients after acute spinal cord injury. *Arch Phys Med Rehabil* 2007;88:1673–80.
21. Thorfinn J, Sjoberg F, Lidman D. Sitting pressure and perfusion of buttock skin in paraplegic and tetraplegic patients, and in healthy subjects: a comparative study. *Scand J Plast Reconstr Surg Hand Surg* 2002;36:279–83.
22. Consortium for Spinal Cord Medicine Clinical Practice Guidelines. Pressure ulcer prevention and treatment following spinal cord injury: a clinical practice guideline for health-care professionals. *J Spinal Cord Med* 2001;24(Suppl 1):S40–101.
23. European Pressure Ulcer Advisory Panel and National Pressure Ulcer Advisory Panel. Pressure ulcer prevention: quick reference guide. Washington, DC: National Pressure Ulcer Advisory Panel; 2009. Available at http://www.epuap.org/guidelines/Final_Quick_Prevention.pdf. Accessed November 20, 2011.
24. Woodbury MG, Houghton PE. Prevalence of pressure ulcers in Canadian health-care settings. *Ostomy Wound Manage* 2004;50:22–38.
25. Anson CA, Shepard C. Incidence of secondary complications in spinal cord injury. *Int J Rehabil Res* 1996;19:55–66.

26. Hizig SL, Tonack M, Campbell KA, McGillvray CF, Boschen KA, Richards K, Craven BC. Secondary health complications in an aging Canadian spinal cord injury sample. *Am J Phys Med Rehabil* 2008;87:545–55.
27. Garber SL, Rintala DH, Hart KA, Fuhrer MJ. Pressure ulcer risk in spinal cord injury: predictors of ulcer status over 3 years. *Arch Phys Med Rehabil* 2000;81:465–71.
28. Raghavan P, Raza WA, Ahmed YS, Chamberlain MA. Prevalence of pressure sores in a community sample of spinal injury patients. *Clin Rehabil* 2003;17:879–84.
29. New PW, Rawicki BH, Bailey M. Nontraumatic spinal cord injury: demographic characteristics and complications. *Arch Phys Med Rehabil* 2002;83:996–1001.
30. Fuhrer MJ, Garber SL, Rintala DH, Clearman R, Hart KA. Pressure ulcers in community-resident persons with spinal cord injuries: prevalence and risk factors. *Arch Phys Med Rehabil* 1993;74:1172–7.
31. Jones ML, Mathewson CS, Adkins VK, Ayllon T. Use of behavioral contingencies to promote prevention of recurrent pressure ulcers. *Arch Phys Med Rehabil* 2003;84:796–802.
32. National Spinal Cord Injury Statistical Center (NSCISC). Annual Report for the Model Spinal Cord Injury Care Systems. Birmingham, AL: NSCISC; 2005
33. Yarkony GM, Heinemann MW. Pressure ulcers. In: Stover SL, DeLisa JA, Whiteneck GG, eds. *Spinal Cord Injury: Clinical Outcomes from the Model Systems*. Gaithersburg, MD: Aspen Publishing; 1995.
34. Chen Y, DeVivo MJ, Jackson AB. Pressure ulcer prevalence in people with spinal cord injury: age-period-duration effects. *Arch Phys Med Rehabil* 2005;86:1208–13.
35. Rintala CH, Garber SL, Friedman JD, Holmes SD. Preventing recurrent pressure ulcers in veterans with spinal cord injury: impact of a structured education and follow-up intervention. *Arch Phys Med Rehabil* 2008;89:1429–41.
36. Sumiya T, Kawamura K, Tokuhiro A, Takechi H, Ogata H. A survey of wheelchair use by paraplegic individual in Japan. Part 2: prevalence of pressure sores. *Spinal Cord* 1997;35:595–8.
37. Wilhelmi BJ. Surgical treatment of pressure ulcers. Available at <http://emedicine.medscape.com/article/1293724-overview#a05>. Accessed November 29, 2012.
38. Krause JS, Broderick L. Patterns of recurrent pressure ulcers after spinal cord injury: identification of risk and protective factors 5 or more years after onset. *Arch Phys Med Rehabil* 2004; 85:1257–64.
39. Cutajar R, Roberts A. Occupations and pressure sore development in Saudi men with paraplegia. *Br J Occup Ther* 2005;68:307–14.
40. Dorsett P, Geraghty T. Depression and adjustment after spinal cord injury: A three-year longitudinal study. *Top Spinal Cord Inj Rehabil* 2004;9(4):43–46.
41. Allman RM. Pressure ulcer prevalence, incidence, risk factors, and impact. *Clin Geriatr Med* 1997;13:421–36.
42. New PW, Rawicki HB, Bailey MJ. Nontraumatic spinal cord injury rehabilitation: pressure ulcer patterns, prediction, and impact. *Arch Phys Med Rehabil* 2004;85:87–93.
43. Maslauskas, K, Samsanavicus D, Rimdeika R, Kaikaris V. Surgical treatment of pressure ulcers: an 11-year experience at the Department of Plastic and Reconstructive Surgery of Hospital of Kaunas University of Medicine. *Medicina (Kaunas)* 2009;45:269–75.
44. Jaglal SB, Munce SEP, Guilcher SH, Couris CM, Fung K, Craven BC, Verrier M. Health system factors associated with rehospitalizations after traumatic spinal cord injury: a population-based study. *Spinal Cord* 2009;47:604–9.
45. Bennett G, Dealy C, Posnett J. The cost of pressure ulcers in the UK. *Age Ageing* 2004;33:230–5.
46. Gentzkow GD, Pollak SV, Kloth LC, Stubbs HA. Improved healing of pressure ulcers using Dermapulse, a new electrical stimulation device. *Wounds* 1991;3:158–70.
47. Zhan C, Miller MR. Excess length of stay, charges, and mortality attributable to medical injuries during hospitalization. *JAMA* 2003;290:1868–74.
48. Garber SL, Rintala DH, Hart KA, Fuhrer MJ. Pressure ulcers in veterans with spinal cord injury: a retrospective study. *J Rehabil Res Dev* 2003;4:433–41.
49. Allen J, Houghton PE. Electrical stimulation: a case study for a stage III pressure ulcer. *Wound Care Canada*. 2004;2:34–6.
50. Chan BS, Nanwq N, Mittmann N, Coyte PC, Bryant DB, Houghton PE. The average cost of pressure ulcer management in a community dwelling spinal cord injury population. *Int Wound J* (in Press).

CONTENTS

INTERPROFESSIONAL TEAM	10
PRINCIPLES	10
Challenge of pressure ulcer prevention	10
Need for improved prevention and treatment	10
Interprofessional spinal cord injury teams	10
Evidence	11
INTERPROFESSIONAL TEAM ACROSS THE CONTINUUM OF CARE	11
Acute care and rehabilitation: specialized units	11
Evidence	11
Community phase: specialized outpatient or outreach services	12
Evidence	12
PRESSURE ULCER RISK FACTORS	12
PRINCIPLES	12
Definitions	12
IDENTIFICATION OF PRESSURE ULCER RISK FACTORS	13
Risk according to etiology of spinal cord injury	14
Risks associated with specific phases of care	14
Prehospital management	14
Acute care	14
Inpatient rehabilitation	15
Community phase	16
PRESSURE ULCER RISK FACTOR ASSESSMENT	18
Risk assessment tools	18
Is it worth using risk assessment scales for pressure ulcers in people with spinal cord injury?	18
Assessment of specific factors affecting risk	20
Deep Tissue Injury	20
CONCLUSIONS	21
REFERENCES	21

Interprofessional team

PRINCIPLES

Challenge of pressure ulcer prevention

Anatomic and physiologic changes occurring as a result of spinal cord injury substantially increase the risk of pressure ulcers. Effective prevention and management of pressure ulcers in this population requires a level of knowledge of both wound care and spinal cord injury that is rarely present in the same individual. Furthermore, relatively few interprofessional clinics exist to apply this combined expertise to the clinical challenge of maintaining skin integrity in people with spinal cord injury.

Need for improved prevention and treatment

Several recent reports have found pressure ulcers among the most common reasons for hospital readmission in people with spinal cord injury.⁽¹⁾ Considering this finding in conjunction with the prolonged length of stay required for pressure ulcer treatment illustrates the significant personal and healthcare system impact of pressure ulcers.

A telephone interview study (n=54) performed by Cox et al identified a substantial need for interprofessional specialist outreach services among community-dwelling individuals with spinal cord injury.⁽²⁾ This needs assessment identified several deficient or absent areas in current community care, including limited local expert knowledge, complicated care processes, and fragmented service delivery.

A group of clinicians who were concerned with the consequences of inadequate care received by some people with spinal cord injury after discharge from the regional spinal cord injury centre published a description of the deficiencies in management of people with spinal cord injury and health problems to draw attention to these issues.⁽³⁾ *These deficiencies highlight the importance of formally comparing clinical outcomes, specifically the incidence of new pressure ulcers and healing time of existing pressure ulcers, that are currently achieved in community-based and problem-based primary care and those provided by a specialized outpatient interprofessional centre.*

Interprofessional spinal cord injury teams

The optimal approach to managing pressure ulcers in people with spinal cord injury is with an interprofessional team with dual expertise in wound care and spinal cord injury. Such a team has the skills to manage the complexities of pressure ulcer prevention and treatment in this population. At a minimum, the team should comprise a physiatrist or other physician specially trained in the management of spinal cord injury care, a nurse with experience in spinal cord injury, an expert wound care clinician with advanced wound care skills, an occupational therapist with knowledge of seating and other adaptive equipment and strategies for people with spinal cord injury, a physiotherapist with knowledge of neurorehabilitation and with both interest and expertise in treating people with chronic wounds, a dietitian with experience in managing people with spinal cord injury and wounds, and a social worker or other counsellor, such as a psychologist or psychiatrist, who can implement and support education in this population.

1.1 Spinal cord injury interprofessional team

Develop an interprofessional spinal cord injury team that includes, at a minimum, a physiatrist (or physician with spinal cord injury training), occupational therapist, physiotherapist, wound care clinician, nurse, psychologist, social worker, and dietitian. Include additional members as local resources allow. Ensure that all team members have knowledge of spinal cord injury and pressure ulcer prevention and care.

RECOMMENDATION LEVEL III



EVIDENCE

Forming interprofessional teams to achieve specific clinical objectives can enhance pressure ulcer prevention and management strategies across the continuum of care for people with spinal cord injury and improve their quality of life. The benefits provide a strong rationale for developing interprofessional spinal cord injury and skin care teams, and, where sufficient need exists, interprofessional clinics.

Mathewson et al described an interprofessional, interdepartmental, multifocused skin care program developed to fit the needs of people with spinal cord injury.⁽⁴⁾ A centre-wide skin care team was developed to evaluate and improve management of people with spinal cord injury across the continuum of care. The team included an inpatient rehabilitation skin team, outpatient wound clinic, medical–surgical skin team, and the research department, including telemedicine projects. This approach improved outcomes and resource use and created a more effective approach to care.⁽⁵⁾

Interprofessional collaboration has been described as involving “interactions of two or more disciplines involving professionals who work together, with intention, mutual respect, and commitment for the sake of a more adequate response to a human problem.”⁽⁶⁾ Interprofessional collaboration goes beyond transdisciplinary cooperation to include not just traditional discipline boundaries but also nontraditional roles, so that professional identities and traditional roles are actively negotiated, rather than being prescribed. Participants in an interprofessional collaboration transcend the perspectives of their individual disciplines to combine resources, including tools, methods, and procedures, to address common problems or concerns. Interprofessional collaborative practice allows a team of healthcare professionals to work together in partnership with a patient in a participatory, collaborative, and coordinated approach to share decision-making around health and social issues and to develop a shared plan of care.⁽⁷⁾

INTERPROFESSIONAL TEAM ACROSS THE CONTINUUM OF CARE

Acute care and rehabilitation: specialized units

1.2: Rapid admission to specialized care

Admit people with spinal cord injury as soon as possible to a specialized spinal cord injury unit staffed by an experienced interprofessional team.

RECOMMENDATION LEVEL III

EVIDENCE

Prevention of common secondary complications such as pressure ulcers, urinary tract infections, and chronic pain begins with optimal rehabilitation provided soon after spinal cord injury⁽¹⁾ An integrated, comprehensive program focused on optimal patient care can provide the needed care with a high level of expertise⁽⁸⁾ Specialized centres with experienced interprofessional teams produce better outcomes than general hospitals. Functional gains are greater and occur more rapidly. Secondary complications, including pressure ulcers, are lower when people with spinal cord injury receive interprofessional rehabilitation.⁽⁹⁾ Delaying⁽³⁴⁾ access to specialized care may result in increased occurrence of pressure ulcers in the future.

Early evaluation also increases the skin management ability of people with spinal cord injury. *Additional research is needed to determine whether these enhanced abilities translate into pressure ulcer reduction in the long term.*



Community phase: specialized outpatient or outreach services

1.3: Community phase: outpatient services

Provide adequate outpatient services where people with spinal cord injury who are living in the community can access an interprofessional team of clinicians with expertise in the management of individuals with spinal cord injury. Ensure that routine follow-up appointments provide preventive care to reduce secondary complications and improve quality of life.

RECOMMENDATION LEVEL III

EVIDENCE

The expertise required to help people with spinal cord injury and pressure ulcers is seldom available in primary care or through community care services. Speciality clinics or outreach services from spinal cord injury centres allow interprofessional team members to communicate more effectively, benefit from each other's expertise, and assess and treat patients more efficiently.

An exploratory study by Dunn et al of providing routine outpatient care in a specialized interprofessional clinic, rather than the usual problem-based primary care setting, found people with spinal cord injury treated in these clinics had improved quality of life, an absence of depression, and fewer and less severe secondary complications, including pressure ulcers.⁽¹⁰⁾ Conversely, the use of a transmural nurse to liaise between community-based healthcare professionals and people with spinal cord injury who were living at home did not improve clinical outcomes.⁽¹¹⁾ This program was plagued with problems in implementing and coordinating community-based services. Difficulty coordinating spinal cord injury-specific services in the community has already been well documented.⁽²⁾

A large (n=127) prospective controlled study performed in three centres in Europe investigated the utility of telemedicine videoconferencing to provide expertise and services to community-dwelling people with spinal cord injury.⁽¹²⁾ No reduction in secondary complications was seen overall, but the site that evaluated the majority of participants reported significant functional gains and fewer pressure ulcers.

Research is necessary to substantiate the benefits of long-term management of people with spinal cord injury by a specialized interprofessional spinal cord injury and skin care team and to explore patterns and trends associated with causative factors for pressure ulcer development.

Pressure ulcer risk factors

PRINCIPLES

Definitions



Pressure is the force per unit area perpendicular to the plane of interest. Pressure at the interface between bone and underlying soft tissue is diffused as the pressure is transmitted toward the interface of the body and the supporting surface.⁽¹³⁾ The amount of pressure diffusion determines the tissue stress, with wider redistribution decreasing stress. Shear stress results from tissue strain or deformation. Tissue deformation depends to a certain extent on the mechanical properties of the tissue and supporting surface, with softer tissues being more susceptible to shear forces. Both pressure and shear forces increase the risk of injury. The pathogenesis of deep tissue injury involves primarily internal tissue stress and strain and differs from that of superficial pressure ulcers.



Several finite element models have demonstrated stress and strain to be greatest in the deeper tissues near the bone rather than at the skin surface.⁽¹³⁾ As a result, deep tissue injury may occur before any damage to superficial tissue.

To investigate the effectiveness of wheelchair cushions, Linder-Ganz and Gefen created three-dimensional models of human buttocks representing progressive severities of muscle atrophy and ischial tuberosity flattening, both of which occur in people with spinal cord injury.⁽¹⁴⁾ The authors developed an algorithm linking finite element modelling, damage laws, and an injury threshold to predict deep tissue injury for different anatomies and cushions of varying stiffness. The volume of damaged muscle increased exponentially with the degree of muscle atrophy, and the rate of progression of deep tissue injury increased substantially. Ischial tuberosity flattening increased muscle injury, producing a larger area of damage and a faster rate of damage than a sharper ischial tuberosity.

Obesity is common among people with spinal cord injury and it is important to determine the impact of obesity on pressure ulcer risk. It has been argued that obesity increases pressure ulcer risk because it increases pressure in deep tissues. It has also been stated that obesity exerts a protective effect by providing an additional cushion over bony prominences. Elsner and Gefen developed computational finite element models of buttocks with different degrees of obesity to investigate this issue.⁽¹⁵⁾ The authors found that obesity had both the postulated effects, but that higher internal stresses and strains overshadowed any cushioning effects of increased adiposity. In addition, the concurrent muscle atrophy seen in spinal cord injury exacerbated the problem, increasing the risk of deep tissue injury.



In addition to pressure and shear, the development of superficial pressure ulcers involves microclimate factors, such as skin surface temperature, humidity, moisture, and air movement, which affect friction.⁽¹⁶⁾ Friction is the resistance to motion in a parallel direction relative to the common boundary of two surfaces.

Gefen performed a modelling study to investigate the effects of microclimate on the susceptibility of the skin to damage from pressure.⁽¹⁷⁾ The study determined that increases in skin temperature, ambient temperature, and relative humidity all increased susceptibility to superficial pressure ulcers. Decreased permeability of materials in contact with, or close to, the skin, such as mattress and wheelchair cushion covers and clothing, are associated with friction. The coefficient of friction of these materials increases with increasing moisture, including perspiration. Friction increases skin susceptibility to superficial pressure ulcers. Ideal textiles have a low coefficient of friction with skin, are permeable, and conduct heat.

IDENTIFICATION OF PRESSURE ULCER RISK FACTORS

The identification of specific pressure ulcer risk factors differs between studies. The Consortium for Spinal Cord Medicine Clinical Practice Guidelines and Spinal Cord Injury Rehabilitation Evidence (SCIRE) found the following pressure ulcer risk factors were more consistently identified in people with spinal cord injury^(18,19):

- **Demographic factors:** increasing age, increasing duration of spinal cord injury, male sex, and lower education level
- **Spinal cord injury-related factors:** higher level and completeness of injury, low level of activity (involvement), immobility, urinary and fecal incontinence, both increased (SCIRE) and decreased spasticity (Consortium for Spinal Cord Medicine), autonomic dysreflexia, lack of sensation, muscle atrophy, and ischial tuberosity flattening
- **Medical and nutritional factors:** number of comorbidities, renal disease, pulmonary disease, sepsis, previous pressure ulcer, decreased protein and albumin, anemia, decreased lymphocyte count, poor nutritional status, being underweight, and increased tissue temperature

- *Physical factors:* physical activity and conditioning, participation in skin health practices, sources of mechanical trauma (pressure, friction, and shear). For example: high sitting pressures and tissue interface pressure; reduced local blood flow; and inability to transfer and perform appropriate pressure relief strategies, as discussed in Chapter 7, Mobility, activity, and conditioning
- *Psychological factors:* depression and anxiety, smoking, and poor motivation
- *Education and self-management:* lack of knowledge and understanding of pressure ulcers, risk factors and preventive strategies, health behaviours, and self-management
- *Organization and system factors:* access to care

Risk according to etiology of spinal cord injury

Using a retrospective cross-sectional design, Taghipoor et al evaluated pressure ulcer risk according to two aspects of spinal cord injury: complete or incomplete injury with spared sensory function, and traumatic or nontraumatic cause of injury.⁽²⁰⁾ The analysis included data on 3,791 cases of traumatic injury and 2,110 people with nontraumatic spinal cord injury. Pressure ulcers were common, occurring in 39.2% of the population evaluated. The traumatic injury group included significantly more males, and the median age was significantly younger than in the nontraumatic group. Congenital injury constituted 40% of the nontraumatic causes of spinal cord injury, contributing to the longer duration of injury in that group. Age was a risk factor only in people with nontraumatic causes of injury, whereas unemployment and lower education level were factors only in people with traumatic spinal cord injury. Traumatic cause, increasing age, male sex, single status, and injury within the previous year were significant pressure ulcer risk factors on logistic regression. The authors speculated that delayed admission to rehabilitation could have accounted for recent injury being a risk factor.

Risks associated with specific phases of care

PREHOSPITAL MANAGEMENT

The strong association between the use of spine boards for immobilization in the acute care setting and the risk of pressure ulcers makes it critical to identify ways of limiting the amount of time a person is kept on a spine board and to develop alternative board designs that protect skin, rather than cause pressure ulcers.

Ahn et al performed a systematic review of studies of prehospital management of people with possible spinal cord injury, focusing on initial immobilization.⁽²¹⁾ Traditional unpadded spine boards produced the highest pressures at the occiput and sacrum, compared with other forms of stretchers. No studies evaluated a safe duration of immobilization or correlated time on a rigid board with pressure ulcer development. Recommendations included minimizing time on hardboards and using padded spine boards or inflatable bean bag boards to reduce the risk of pressure damage without compromising biomechanical immobilization.

ACUTE CARE

Gélis et al performed a systematic review of the literature to identify pressure ulcer risk factors during the acute, rehabilitation, and chronic stages of spinal cord injury. Six studies dealing with the acute stage and no studies dealing with rehabilitation met the inclusion criteria.⁽²²⁾ Of the six studies, five were historical cohort (chart review) studies and one was a prospective cohort study. These studies included 1,061 people. Risk factors for pressure ulcer development during the acute post-injury stage were associated primarily with medical management. Moderate evidence supported transport time and time on a long spine board as pressure ulcer risk factors. Although length of stay appeared to increase pressure ulcer risk, insufficient evidence was available to define length of stay as a risk factor. The only clinical factor identified was low blood pressure on arrival at the emergency room, with a moderate level of evidence.

Sae-Sia et al evaluated the impact of a 2-hour duration of pressure loading on sacral skin blood flow and temperature in the following groups: 20 people with spinal cord injury, 24 to 96 hours after injury; 35 people with acute orthopedic



trauma; and 47 healthy individuals.⁽²³⁾ Baseline skin temperature was higher ($p < .05$) in people with spinal cord injury than in the other groups. Over the 2-hour period, sacral skin blood flow decreased ($p < .01$) and skin temperature increased ($p < .001$) less in people with spinal cord injury relative to the other groups. After pressure release, reactive hyperemia occurred significantly more rapidly and to a greater degree in people with spinal cord injury than in the other groups.

The findings indicate microvascular dysfunction in people with acute spinal cord injury, suggesting vessel collapse and decreased ability to maintain skin blood flow during pressure loading. Mean interface pressures were approximately 24 mm Hg, theoretically below the capillary closing pressure.



These data suggest that a 2-hour turning interval for people with acute spinal cord injury may not be optimal, especially when these data are considered in conjunction with the high frequency of pressure ulcer development during acute care.

CHAPTER 5, *Beds, mattresses, and recumbent positioning, includes recommendations for repositioning schedules and pressure ulcer preventive strategies during acute care.*

INPATIENT REHABILITATION

A retrospective study of pressure ulcers in 134 people undergoing initial rehabilitation or readmission for nontraumatic spinal cord injury found 31.3% of people had a pressure ulcer at admission, and 2.2% developed a pressure ulcer during rehabilitation.⁽²⁴⁾

The only predictor significantly increasing the risk of pressure ulcer among people undergoing initial rehabilitation was age, whereas significant predictors among people readmitted to rehabilitation were ASIA grade and anemia. The high incidence of pressure ulcers during acute treatment of spinal cord injury demands improved awareness and preventive strategies during acute care.

Verschueren et al performed a multicentre prospective cohort study to evaluate the occurrence and predictors of pressure ulcers in people with spinal cord injury during initial inpatient rehabilitation, comprising acute and functional rehabilitation.⁽²⁵⁾ This study, which includes data on 193 people at eight centres, provides the first insights into risk factors during this period. Acute rehabilitation, beginning at admission to the rehabilitation facility, had a median duration of 35 days. Functional rehabilitation, beginning when the person could sit in a wheelchair for 3 to 4 hours, lasted a median 191 days. People were assessed at the beginning of functional rehabilitation and at discharge. The prevalence of pressure ulcers was 36.5% during acute rehabilitation and 39.4% during functional rehabilitation. Significant pressure ulcer risk factors during functional rehabilitation were complete injury, tetraplegia, pressure ulcer during acute rehabilitation, pneumonia or pulmonary disease, and low scores on the Functional Independence Measure subscales for self-care, continence, transfers, locomotion, and total motor score. The strongest risk factor was occurrence of pressure ulcer during acute rehabilitation.

Specialized centres with experienced interprofessional teams produce better outcomes than general hospitals. Functional gains are greater and occur more rapidly. Secondary complications, including pressure ulcers, are lower when people with spinal cord injury receive interprofessional rehabilitation.⁽²⁶⁾

Early specialized evaluation also increases the skin management ability of people with spinal cord injury, but additional research is needed to determine whether these enhanced skin management abilities translate into pressure ulcer reduction in the long term.



COMMUNITY PHASE

A telephone survey of 58 men with paraplegia investigated the link between decreased participation in occupational activities and pressure ulcers.⁽²⁷⁾ The study found significant associations between unemployment and pressure ulcers requiring hospitalization, and between independence in activities of daily living and decreased number of pressure ulcers experienced during the previous 2 years. Individuals who participated more frequently in leisure activities had fewer pressure ulcers.

A survey adapting questions from the Behavioral Risk Factor Surveillance System survey to people with spinal cord injury was mailed to veterans with spinal cord injuries and disorders.⁽²⁸⁾ Smith et al used data from 2,574 respondents to evaluate pressure ulcer occurrence and risk factors in this population.⁽²⁸⁾ No significant difference was seen between individuals with pressure ulcers (36%) and those without pressure ulcers (64%) over the previous 12 months in age, race, education, neurologic level, or duration of injury. Factors significantly associated with pressure ulcer were diabetes, smoking, injury duration greater than 30 years, and frequent depressive symptoms.

Garber et al used interviews, questionnaires, and physical examinations at baseline and 3 years later to assess pressure ulcer risk factors in 118 men with spinal cord injury living in the community.⁽²⁹⁾ Approximately one-third of study participants reported experiencing a pressure ulcer in the 12 months before the baseline evaluation, and a similar percentage reported having an ulcer in the 12 months before the 3-year assessment. Almost 60% had a pressure ulcer at the 3-year point. The main factors associated with increased risk were previous pressure ulcers, especially if surgery was required, and people's beliefs that they were susceptible to pressure ulcers. Other associated factors were younger age at, and longer duration of, spinal cord injury, a greater degree of impairment, and difficulty with good skin care practices.

Gélis et al identified 14 studies evaluating pressure ulcer risk during the chronic stage (after completion of rehabilitation) of spinal cord injury, of which nine were cross-sectional studies, four were cohort studies, and one was a case-control study.⁽³⁰⁾ These studies included 15,827 people. The review confirmed many of the traditionally accepted risk and protective factors for pressure ulcer development (Table 1).⁽³⁰⁾

Table 1. Pressure Ulcer Risk and Protective Factors in Chronic Spinal Cord Injury Stage

FACTORS	RISK	PROTECTIVE	UNRELATED	LEVEL OF EVIDENCE
DEMOGRAPHIC FACTORS				
Male sex	X			Strong
Age			X	Strong
Marriage		X		Moderate
Low education level	X			Moderate
Being employed or a student		X		Moderate
SPINAL CORD INJURY-RELATED FACTORS				
Young age at injury	X			Moderate
Longer time since injury	X			Strong
Spinal cord injury caused by trauma			X	Moderate
Cervical level of injury			X	Strong
Transverse extension of spinal cord injury	X			Strong

FACTORS	RISK	PROTECTIVE	UNRELATED	LEVEL OF EVIDENCE
Vertical extension of spinal cord injury	X			Moderate
PHYSICAL AND MEDICAL FACTORS				
Diabetes			X	Insufficient
Deep vein thrombosis	X			Strong
Pneumonia	X			Strong
Leg fracture	X			Moderate
Autonomic dysreflexia	X			Moderate
Pressure ulcer history	X			Strong
Low albumin	Potential			Insufficient
IMPAIRMENT AND DISABILITY				
Disability (Functional Independence Measure)	X			Moderate
Handicap	X			Insufficient
Low mobility level	X			Moderate
Urinary Incontinence	X			Insufficient
BEHAVIOURS				
Skin-specific protective behaviours		Potential		Insufficient
Daily skin monitoring		X		Moderate
Physical activity		Potential		Insufficient
Healthy diet		Potential		Insufficient
Healthy lifestyle		Potential		Insufficient
Smoking	X			Moderate
Alcohol use			X	Moderate
Use of sleeping pills	Potential			Insufficient
PSYCHOLOGICAL FACTORS				
Depression	Potential			Insufficient
Anxiety	Potential			Insufficient
Self-esteem			X	Insufficient

Pressure ulcer risk factor assessment

RISK ASSESSMENT TOOLS



1.4: Risk assessment tools

Use the Waterlow Scale, the Braden Scale, or the Spinal Cord Injury Pressure Ulcer Scale (SCIPUS) tool to assess pressure ulcer risk in people with spinal cord injury.

RECOMMENDATION LEVEL IIA



1.5: Risk factor management

Use the results of a comprehensive and systematic assessment of pressure ulcer risk factors to select and implement risk management strategies in individuals with spinal cord injury.

RECOMMENDATION LEVEL IV



1.6: Risk factor reassessment

Reassess risk factors on a routine basis, as determined by the healthcare setting, institutional guidelines, and changes in the individual's health status.

RECOMMENDATION LEVEL IV



Assessment of pressure ulcer risk is more effectively performed using an objective risk assessment tool than clinical judgment. Numerous tools exist, not all of which have been validated for use on people with spinal cord injury.

Balzer et al compared the validity of the Norton, Braden, Waterlow, and Care Dependency scales in identifying risk.⁽³¹⁾ The authors found the Waterlow Scale had the highest sensitivity (86%) and the Norton Scale had the highest specificity (76%). Using a cut-off value of 55, the Care Dependency Scale had a sensitivity of 74% and a specificity of 83%.

IS IT WORTH USING RISK ASSESSMENT SCALES FOR PRESSURE ULCERS IN PEOPLE WITH SPINAL CORD INJURY?

Anthony et al summarized issues identified with the Norton, Braden, and Waterlow scales during 25 years' clinical experience and assessed these scales against ideal attributes.⁽³⁴⁾

- Scale complexity is unwarranted, as many components do not predict pressure ulcers. Of 11 Waterlow subscores, only three predicted pressure ulcers in a wheelchair population (gender, skin, and mobility) and only five predicted pressure ulcers in hospitalized people (appetite, continence, skin, surgery, and age).
- Other variables available to clinicians have predictive power. Hypoalbuminemia alone outperformed the Waterlow Scale, and the combination of hemoglobin, C-reactive protein, albumin, age, and gender outperformed the Braden Scale in one study.
- Scale components are not independent; some could be removed without affecting predictive power. Factor analysis has found that risk tools contain fewer factors than suggested by the number of subscores, with the Waterlow Scale having three factors and the Braden Scale having one.

No evidence indicates that using risk assessment scales reduces pressure ulcer incidence above what occurs due to the Hawthorne effect, which states that simply evaluating a problem improves it. Very few studies address reduction in pressure ulcers as an outcome when risk assessment scales are used, and none demonstrates a positive effect.

The authors concluded that pressure ulcer assessment scales contain unnecessary items, omit useful items, use suboptimally scaled subscores, and contain correlated factors.⁽³⁴⁾ In addition, these scales may not perform better than clinical judgment.

Wellard and Lo evaluated the sensitivity of the Norton, Braden, and Waterlow scales to identify pressure ulcer risk in people with spinal cord injury.⁽³²⁾ The authors performed a retrospective medical history audit of admissions to a spinal cord injury unit during a 5-year period (June 1992 – June 1997). Of 204 admissions with a diagnosis of pressure ulcer, 60 records were audited using a quota sampling strategy. The overall average scores were 15.4 (SD ± 1.10, range 12–17) for the Norton Scale, 18.9 (SD ± 2.98, range 15–28) for the Waterlow Scale, and 13.8 (SD ± 1.75, range 10–18) for the Braden Scale. Categorizing these scores by risk level using the Norton Scale found 86% of people with no risk, 8% with risk, and 2% with high risk. Using the Braden Scale, 4% had no risk, 29% had low risk, 49% had moderate risk, and 21% had high risk. With the Waterlow Scale, 64% had high risk and 36% had very high risk. The analysis concluded that the Waterlow Scale had the highest predictive value. Although a prospective evaluation would provide stronger evidence of sensitivity than a retrospective analysis, the authors suggested the Waterlow Scale be used until a more specific tool was developed.

Mortenson et al reviewed the Abruzzese, Braden, Gosnell, Norton, Spinal Cord Injury Pressure Ulcer Scale–Acute (SCIPUS-A), SCIPUS, and Waterlow scales in people with spinal cord injury (Table 2).⁽³³⁾ With over 200 pressure ulcer risk factors identified for the spinal cord injury population, the authors pointed out the importance of determining which ones should be included in a risk assessment tool for this population. They used linear regression to select items for the SCIPUS and SCIPUS-A, but whether all important variables were considered is unknown. The items selected, however, demonstrate differences in important risk factors between people with spinal cord injury and the general population. Validity data were poor for the Abruzzese and Gosnell scales and adequate for the other scales. The authors concluded that the Braden Scale may be the best available tool.

Table 2. Risk Assessment Tools: Summary of Psychometric Properties (*Adapted from Mortenson et al., (33) with permission.*)

MEASURE	ABRUZZESE	BRADEN	GOSNELL	NORTON	SCIPUS	SCIPUS-A	WATERLOW
Reliability	—	—	—	—	—	—	—
Validity	Poor	Poor–adequate	Poor	Poor–adequate	Adequate	Adequate	Adequate
Respondent burden	Excellent	Excellent	Excellent*	Excellent	Excellent †	Excellent†	Excellent
Administrative burden	Adequate	—	Adequate	Adequate	Adequate	Adequate	Adequate

SCIPUS: *Spinal Cord Injury Pressure Ulcer Scale*; SCIPUS-A: *Spinal Cord Injury Pressure Ulcer Scale–Acute*

—: *no information available for spinal cord injury*

**If skin status assessment is omitted*

† *If blood testing results already available; otherwise, adequate*

Few data are available on the performance of risk assessment tools in the spinal cord injury population. Further research is required in the following areas:

- *A demonstration of reliability and predictive validity of the Braden Scale in the spinal cord injury population.*
- *A larger scale study to evaluate the predictive ability of the Waterlow scale in the spinal cord population is required.*
- *Additional evaluation of the SCIPUS scales is required before recommending them for clinical use.*
- *Determining whether the use of pressure ulcer risk assessment tools can reduce the incidence of pressure ulcers is critical.*



According to the Waterlow Scale, all people with spinal cord injury have a high risk of pressure ulcer. It is therefore logical to consider a universal pressure ulcer prevention program for people with spinal cord injury.

ASSESSMENT OF SPECIFIC FACTORS AFFECTING RISK

Deep Tissue Injury

1.7: Assess deep tissue injury

Consider ultrasound imaging of the tissue overlying the ischial tuberosity in suspected deep tissue injury.

RECOMMENDATION LEVEL III



Among people with spinal cord injury who use a wheelchair, the gluteus maximus muscles under the ischial tuberosities are the areas with the greatest risk of pressure ulcer development, especially from deep tissue injury. Interface pressure does not measure deep tissue strains and stresses.

Linder-Ganz et al developed a noninvasive, generic, real-time, subject-specific method of performing finite element modelling of the buttocks.⁽³⁵⁾ Continuous monitoring of deep tissue compressed between bony prominences and a support surface, combined with pressure mat measurements, was performed over 90 minutes sitting on an air-filled cushion, with three people with spinal cord injury and three healthy controls. Stresses were substantially higher in people with spinal cord injury than in controls, at least partly as a result of gluteal muscle atrophy and ischial tuberosity flattening seen in this population.

The real-time finite element method allows monitoring of individual stress over time, including different postures, cushions, and wheelchairs. This method has potential clinical applications in rehabilitation and pressure ulcer prevention, including providing individual feedback on moment-to-moment risk, developing alarm systems for warning about excessive deep tissue loads, and evaluating the effect of different cushions, inflation pressures, and wheelchair adjustments.

The best method to detect and evaluate deep tissue injury has not been determined. A study of intermediate-frequency ultrasonography as a tool to evaluate deep tissue injury involved 12 people with spinal cord injury who had signs of deep tissue injury on ultrasound. Participants were followed until the ulcers reached a final stage.⁽³⁶⁾ Ulcers worsened in six participants and healed in the remaining six. Abnormal ultrasound findings unique to deep tissue injury were the following:

- Unclear layered structure, detected in all participants
- Hypochoic lesions, detected in ten participants
- Discontinuous fascia, detected in seven participants
- Heterogeneous hypochoic areas, detected in five participants



Studies suggested discontinuous fascia and heterogeneous hypochoic areas were more reliable predictors of future progression of pressure ulcers than the other features. Ultrasound evaluation reliably identified deep tissue injury and allowed treatment and prevention of pressure ulcers. This imaging modality may allow early detection of subclinical deep tissue injury before signs are evident on the skin and may also allow prediction of ulcers that are likely to progress.

 See **CHAPTER 2**, *Human factors affecting pressure ulcer prevention, for information on assessment of psychosocial factors affecting pressure ulcer risk, and CHAPTER 3*, *Body weight, nutrition, and hematologic and biochemical parameters of healing, for information on assessment of health status and pressure ulcer risk.*



CONCLUSIONS

Any person with spinal cord injury who has had a pressure ulcer must be considered to be at high risk for pressure ulcer. Standardized risk assessment using an objective tool is recommended over clinical judgment as the best approach to assessing risk.

The ideal tool to assess the risk of pressure ulcers in people with spinal cord injury has not yet been developed. The Waterlow Scale, however, is the most sensitive tool currently available, with the highest predictive value.

SCIPUS appears to be a promising risk assessment tool, as it has been specifically designed to address risk factors in people with spinal cord injury, but research is needed to validate its use.

The overall objective of assessing risk is to improve outcomes. To achieve this objective, assessment results must be used to identify appropriate interventions, and these interventions must be implemented. Risk factors need to be reassessed as individual medical and environmental factors change.

REFERENCES

1. Wolfe DL, Hsieh JTC, Mehta S. Rehabilitation practices and associated outcomes following spinal cord injury. In Eng JJ, Teasell RW, Miller WC, Wolfe DL, Townson AF, Hsieh JTC, et al, eds. *Spinal Cord Injury Rehabilitation Evidence*, 2010. Version 3.0. Available at <http://www.scireproject.com/>. Accessed November 20, 2011.
2. Cox RJ, Amsters DI, Pershouse KJ. The need for a multidisciplinary outreach service for people with spinal cord injury living in the community. *Clin Rehabil* 2001;15:600–6.
3. Vaidyanathan S, Singh G, Soni BM, Hughes PL, Mansour P, Oo T, et al. Do spinal cord injury patients always get the best treatment for neuropathic bladder after discharge from regional spinal injuries centre? *Spinal Cord* 2004;42:438–42.
4. Mathewson CS, Nemeth M, Murray H. Pressure ulcers: interdisciplinary approach across the continuum. *Top Spinal Cord Inj Rehabil* 2000;6(Suppl):91–5.
5. Jones ML, Mathewson CS, Adkins VK, Ayllon T. Use of behavioral contingencies to promote prevention of recurrent pressure ulcers. *Arch Phys Med Rehabil* 2003 84:796–802.
6. Harbaugh GL. Assumptions of inter-professional collaboration interrelatedness and wholeness. In Casto RM and Julia MC, eds. *Inter-professional Care and Collaborative Practice: Commission on Interprofessional Education and Practice*. Pacific Grove, CA: Brooks/Cole; 1999. pp.11–21.
7. Orchard C, Curran V. Creating the culture for interdisciplinary collaborative professional practice. *Medical Education Online* 2005;10: 1–13.
8. Donovan WH, Carter RE, Bedbrook GM, Young JS, Griffiths ER. Incidence of medical complications in spinal cord injury: patients in specialised, compared with non-specialised centres. *Paraplegia* 1984;22:282–90.
9. Smith M. Efficacy of specialist versus non-specialist management of spinal cord injury within the UK. *Spinal Cord* 2002;40:10–6.
10. Dunn M, Love L, Ravesloot C. Subjective health in spinal cord injury after outpatient healthcare follow-up. *Spinal Cord* 2000;38:84–91.
11. Bloemen-Vrencken JH, de Witte LP, Post MW. Follow-up care for persons with spinal cord injury living in the community: a systematic review of interventions and their evaluation. *Spinal Cord* 2005;43:462–75.
12. Dallolio L, Menarini M, China S, Ventura M, Stainthorpe A, Soopramanien A, et al. Functional and clinical outcomes of telemedicine in patients with spinal cord injury. *Arch Phys Med Rehabil* 2008;89:2332–41.
13. Berlowitz DR, Brienza DM. Are all pressure ulcers the result of deep tissue injury? A review of the literature. *Ostomy Wound Manage* 2007;53:34–8.

14. Linder-Ganz E, Gefen A. Stress analysis coupled with damage laws to determine biomechanical risk factors for deep tissue injury during sitting. *J Biomech Eng* 2009;131:011003.
15. Elsner JJ, Gefen A. Is obesity a risk factor for deep tissue injury in patients with spinal cord injury? *J Biomech* 2008;41:3322–31.
16. International Review. Pressure ulcer prevention: pressure, shear, friction and microclimate in context. A consensus document. London: Wounds International; 2010.
17. Gefen A. How do microclimate factors affect the risk for superficial pressure ulcers: a mathematical modeling study. *J Tissue Viability* 2010 November 4. Epub ahead of print.
18. Consortium for Spinal Cord Medicine Clinical Practice Guidelines. Pressure ulcer prevention and treatment following spinal cord injury: a clinical practice guideline for health-care professionals. *J Spinal Cord Med* 2001;24(Suppl 1):S40–101.
19. Regan M, Teasell RW, Keast D, Aubut JL, Foulon BL, Mehta S. Pressure ulcers following spinal cord injury. In: Eng JJ, Teasell RW, Miller WC, Wolfe DL, Townson AF, Hsieh JTC, et al, eds. *Spinal Cord Injury Rehabilitation Evidence*, 2010. Version 3.0.
20. Taghipoor KD, Arejan RH, Rasouli MR, Saadat S, Moghadam M, Vaccaro R, Rahimi-Movaghar V. Factors associated with pressure ulcers in patients with complete or sensory-only preserved spinal cord injury: is there any difference between traumatic and nontraumatic causes? *J Neuosurg Spine* 2009;11:438–44.
21. Ahn H, Singh J, MacDonald RD, Travers A, Tallon J, Fehlings M, Yee, A. Pre-hospital care management of a potential spinal cord injured patient: a systematic review of the literature and evidence-based guidelines. *J Neurotrauma* 2010;27:1–21.
22. Gélis A, Dupeyron A, Legros P, Benaïm C, Pelissier J, Fattal C. Pressure ulcer risk factors in persons with SCI: part I: acute and rehabilitation stages. *Spinal Cord* 2009;47:99–107.
23. Sae-Sia W, Wipke-Tevis DD, Williams DA. The effect of clinically relevant pressure duration on sacral skin blood flow and temperature in patients after acute spinal cord injury. *Arch Phys Med Rehabil* 2007;88:1673–80.
24. New PW, Rawicki HB, Bailey MJ. Nontraumatic spinal cord injury rehabilitation: pressure ulcer patterns, prediction, and impact. *Arch Phys Med Rehabil* 2004;85:87–93.
25. Verschueren JHM, Post MWM, de Groot S, van der Woude LHV, van Asbeck FWA, Rol M. Occurrence and predictors of pressure ulcers during primary in-patient spinal cord injury rehabilitation. *Spinal Cord* 2011;49:106–12.
26. Smith M. Efficacy of specialist versus non-specialist management of spinal cord injury within the UK. *Spinal Cord* 2002;40:10–6.
27. Cutajar R, Roberts A. The relationship between engagement in occupations and pressure sore development in Saudi men with paraplegia. *Br J Occup Ther* 2005;68:307–14.
28. Smith BM, Guihan M, LaVela SL, Garber SL. Factors predicting pressure ulcers in veterans with spinal cord injuries. *Am J Phys Med Rehabil* 2008;87:750–7.
29. Garber SL, Rintala DH, Hart KA, Fuhrer MJ. Pressure ulcer risk in spinal cord injury: predictors of ulcer status over 3 years. *Arch Phys Med Rehabil* 2000;81:465–71.
30. Gélis A, Dupeyron A, Legros P, Benaïm C, Pelissier J, Fattal C. Pressure ulcer risk factors in persons with spinal cord injury: part 2: the chronic stage. *Spinal Cord* 2009;47:651–61.
31. Balzer K, Pohl C, Dassen T, Halfens R. The Norton, Waterlow, Braden, and Care Dependency Scales: comparing their validity when identifying patients' pressure sore risk. *J Wound Ostomy Continence Nurs* 2007;34:389–98.
32. Wellard S, Lo SK. Comparing Norton, Braden and Waterlow risk assessment scales for pressure ulcers in spinal cord injuries. *Contemporary Nurse* 2000;9:155–60.
33. Mortenson WB, Miller WC, and the SCIRE Research Team. A review of scales for assessing the risk of developing a pressure ulcer in individuals with SCI. *Spinal Cord* 2008;46:168–75.
34. Anthony D, Papanikolaou P, Parboteeah S, Saleh M. Do risk assessment scales for pressure ulcers work? *J Tissue Viability* 2010;19:132–6.
35. Linder-Ganz E, Yarnitzky G, Yizhar Z, Siev-Ner I, Gefen A. Real-time finite element monitoring of sub-dermal tissue stresses in individuals with spinal cord injury: toward prevention of pressure ulcers. *Ann Biomed Eng* 2009;37:387–400.
36. Aoi N, Yoshimura K, Kadono T, Nakagami G, Iizuka S, Higashino T, et al. Ultrasound assessment of deep tissue injury in pressure ulcers: possible prediction of pressure ulcer progression. *Plast Reconstr Surg* 2009;124:540–50.

CONTENTS

SKIN CARE	25
NEUROLOGICALLY IMPAIRED SKIN	25
Maintaining skin integrity	25
CONTINUUM OF CARE	26
Pressure ulcer prevention during acute care	26
Evidence	27
Prevention during rehabilitation and the community phase	27
Skin inspection	27
Pressure-redistributing activities	29
PSYCHOSOCIAL FACTORS	29
INTERACTION BETWEEN PSYCHOSOCIAL FACTORS AND PRESSURE ULCERS	29
Psychosocial risk factors	29
Quality of life after spinal cord injury	29
Pain	30
Depression	31
Psychosocial impairment	32
Personality disorder	32
Psychosocial interventions	32
LIFESTYLE	33
RISK FACTORS, PREVENTION, AND INTERVENTIONS	33
Principles explaining pressure ulcer development	34
Clinical lifestyle intervention program	34
BELIEFS AND BEHAVIOURS	35
BELIEFS	35
Skin care beliefs	35
Pressure ulcer experience	36
BEHAVIOURS	37
Testing the theory of planned behaviour	37
Pressure ulcer prevention behaviours	37
Behavioural responses to pressure ulcer	38

EDUCATION AND BEHAVIOUR CHANGE	39
INTERVENTIONS	39
Education	39
Evidence	39
Behaviour-contingent structured education	40
Structured education and follow-up	40
Risk assessment and feedback	41
SELF-MANAGEMENT	41
CONCEPTS AND APPROACHES.....	41
5-A conceptual framework	42
Skin Management needs assessment checklist	42
Peer support	43
Perceptions of pressure ulcer prevention	43
Educational needs	43
SELF-MANAGEMENT PROGRAMS.....	44
Registered Nurses' Association of Ontario	44
British Columbia Paraplegic Association Provincial Peer Program.....	44
SCI-U	44
SpinalCordConnections.ca.....	44
Spinal Cord Injury Solutions Alliance.....	45
INFORMATION SOURCES FOR PEOPLE WITH SPINAL CORD INJURY	45
CONCLUSION	45
REFERENCES	46

Among pressure ulcer risk factors, possibly most critical, but most difficult to quantify, predict, and often influence are a broad range of human factors such as attitudes, beliefs, knowledge, motivation, mood, values, lifestyle issues, and adherence to recommended behaviours, including diet, exercise, and pressure management. What these factors have in common is their impact on pressure ulcer risk, on the success of pressure ulcer prevention education, and on adherence to self-management strategies. Ultimately, human factors determine whether a person works actively to prevent pressure ulcers or not. As a result, these factors are best considered together.

Skin care

NEUROLOGICALLY IMPAIRED SKIN

The neurologic impairment of spinal cord injury produces a variety of metabolic and physiologic changes that interfere with the normal function of the skin and significantly affect its integrity and wound healing.⁽¹⁾ Spinal cord injury above the T6 neurologic level results in loss of reflex sweating. As a result, individuals with this level of injury must be cautious in hot environments, as the body is unable to cool itself.

 Consult **APPENDIX 1** of this document to see the changes that occur after spinal cord injury.

Metabolic changes in neurologically impaired skin may not stabilize for 3 to 5 years after the injury. Collagen catabolism increases significantly and rapidly, decreasing the concentration of amino acids in the skin.⁽²⁾ In addition, the activity of collagen synthase in the skin below the level of injury decreases, and the proportion of type III collagen below the neurologic level increases, resulting in defective collagen synthesis and decreased tensile strength of skin.⁽³⁾ Increased urinary excretion of glycosaminoglycans (GAGS) signals a decrease in proteoglycans, the ground substance surrounding collagen, decreasing skin elasticity and its ability to tolerate trauma.^(4,5)

The density of epidermal adrenergic receptors decreases below the neurologic level, with a greater decrease in people with tetraplegia than those with paraplegia, and this may be responsible for the sensitivity of denervated skin to tissue ischemia.⁽⁶⁾ Normal skin may be able to tolerate ischemia 3 hours longer than denervated skin.

 For more detail on changes in skin as a result of spinal cord injury, refer to: *Consortium for Spinal Cord Medicine Clinical Practice Guidelines. Pressure ulcer prevention and treatment following spinal cord injury: a clinical practice guideline for health-care professionals. J Spinal Cord Med 2001;24(Suppl 1):S40–101.*

Maintaining skin integrity

The fragile skin of people with spinal cord injury requires regular and gentle care to maintain its integrity and barrier function.

 Updated guidelines for pressure ulcer prevention from the Registered Nurses' Association of Ontario (RNAO) and from the National Pressure Ulcer Advisory Panel (NPUAP) European Pressure Ulcer Advisory Panel and they contain several recommendations on general skin care, summarized below^(7,8):

- Cleansing:
 - » Use a pH-balanced, non-sensitizing skin cleanser and warm water.
 - » Handle skin gently during cleansing to minimize force and friction.
- Hydration:
 - » Monitor fluid intake to ensure adequate hydration.
 - » Use a non-sensitizing, pH-balanced, fragrance-free, alcohol-free emollient moisturizer, as dry skin appears to be an independent and significant pressure ulcer risk factor.

- Protection:
 - » Protect skin from excessive moisture, including incontinence.
 - » Use a topical barrier to protect skin from moisture; do not use products that may compromise the absorptive capacity of incontinent briefs. Moisture changes the mechanical properties of the stratum corneum, reducing its strength.
 - » Use protective barriers, such as liquid barrier films, transparent films, hydrocolloids, or protective padding to reduce friction.
- Prevention of skin damage:
 - » Avoid rubbing skin vigorously. Vigorous rubbing may be painful and may cause inflammation or destruction of tissue, especially in frail elderly individuals.
 - » Do not massage the skin to prevent pressure ulcers. Massage is contraindicated if the skin is fragile or inflammation is present; blood vessels may be damaged.
 - » Do not turn the individual onto a body surface that is still red from previous weight bearing. Redness indicates that the body requires additional time to recover from the previous pressure loading.

2.1: Prevention of skin damage

If skin irritation due to moisture develops or persists, pursue a consultation with a nurse with continence training for evaluation, topical treatment, and review of the bowel and bladder program.

RECOMMENDATION LEVEL III

Good skin health increases tolerance to external forces and reduces the likelihood of skin breakdown.⁽⁹⁾ No evidence exists to suggest that the skin of people with spinal cord injury responds any differently to skin health products (moisturizers and protectants) compared to normally innervated skin, but these products have not been systematically tested in people with spinal cord injury.

Development or persistence of skin irritation due to moisture signals the need for a consultation with an advanced practice nurse and the appropriate interprofessional team members for evaluation, topical treatment, and review of the bowel and bladder program. It is important to select continence products using standardized performance indicators such as breathability, air permeability, and other factors. The American-based National Association for Continence (www.nafc.org) is currently developing standards for continence products.

CONTINUUM OF CARE

Strategies to maintain skin integrity are applicable at all times. In addition, different phases of care after spinal cord injury may present specific challenges to skin health.

Pressure ulcer prevention during acute care

2.2: Prevention during prehospital and acute care

As soon after spinal cord injury as emergency medical and spinal stabilization status allow, review individual risk factors and implement appropriate pressure ulcer prevention strategies that:

	RECOMMENDATION LEVEL
■ Avoid prolonged immobilization whenever possible.	IIb
■ Limit the time a person is on a spinal board.	Ia
■ Employ intraoperative pressure reduction strategies.	IIb

RECOMMENDATION LEVEL IA–IIB

EVIDENCE

The first few hours and days after injury carry a high pressure ulcer risk for individuals who have sustained a spinal cord injury.⁽¹⁾ Risk is related primarily to the duration of unrelieved pressure before admission to acute care and to the time spent immobilized on a spinal board. Studies have found that people with spinal cord injury admitted to specialized spinal cord injury units within a week of injury were less likely to develop pressure ulcers than those admitted after that time.

 **CHAPTER 1** *Pressure ulcer prevention and the interprofessional team, provides recommendations for the use of spine boards during the acute phase after spinal cord injury. In particular, please refer to the systematic review by Ahn and colleagues.⁽¹⁰⁾*

An intervention study in an acute spinal cord injury unit assessed the effect of implementing the routine use of pressure-redistribution mattresses and a motivated and educated turning team on reducing the development of new pressure ulcers.⁽⁹⁾ The study demonstrated that implementation of this approach prevented development of new pressure ulcers. This finding underscores the importance of pressure ulcer prevention in the acute setting.  **CHAPTER 5**, *Beds, mattresses, and recumbent positioning, provides recommendations for the use of pressure-redistributing surfaces.*

A pressure-redistribution strategy that is practised commonly in acute care and other hospital settings is regular turning schedules.  **CHAPTER 5**, *Beds, mattresses, and recumbent positioning, provides recommendations for appropriate turning schedules.*

Prevention during rehabilitation and the community phase

SKIN INSPECTION

2.3: Skin inspection

Conduct comprehensive daily visual and tactile skin inspections during rehabilitation and initial community reintegration, paying special attention to the areas that are most vulnerable to pressure ulcer development.

RECOMMENDATION LEVEL IV

It is essential to inspect the skin at least once, and preferably twice, daily.⁽¹⁾ Frequent inspection promotes familiarity with normal skin appearance and allows early detection of impending skin damage. Early superficial pressure ulcers (stage I) may not be recognized until they become more severe. Education for self-identifying stage I pressure ulcers is critical to early intervention. This education includes understanding the influence of posture, positioning, repositioning schedules, and functional use of support surfaces on pressure ulcer development.⁽¹¹⁾ It is important to increase the frequency of skin inspection in the following situations:

- During and after bed rest
- When performing a trial of new equipment
- When changes in lifestyle affect sitting duration
- When any problems are identified
- When a medical condition deteriorates



Some individuals with paraplegia may be able to inspect their own skin using a mirror with a long handle (*Figure 1*), whereas individuals with higher-level paraplegia or tetraplegia need the assistance of a caregiver or healthcare professional. If the individual with spinal cord injury cannot perform skin inspections, it is best for a single person to assist with this task consistently, as familiarity with normal skin appearance is necessary to detect early changes.



Figure 1. Visual check of skin using mirror

Visual inspection should search for redness, discoloration, and bruising; changes in texture, such as rashes, dryness, and swelling; and abnormalities such as cracks, scabs, and blisters. Tactile inspection should evaluate skin temperature, moisture, and induration, or bogginess. The most common sites for pressure ulcers are the ischii, sacrum, and trochanters (*Figure 2*). It is also important to assess other bony prominences, including the occiput, heels, ankles, knees, scapulae, and elbows.

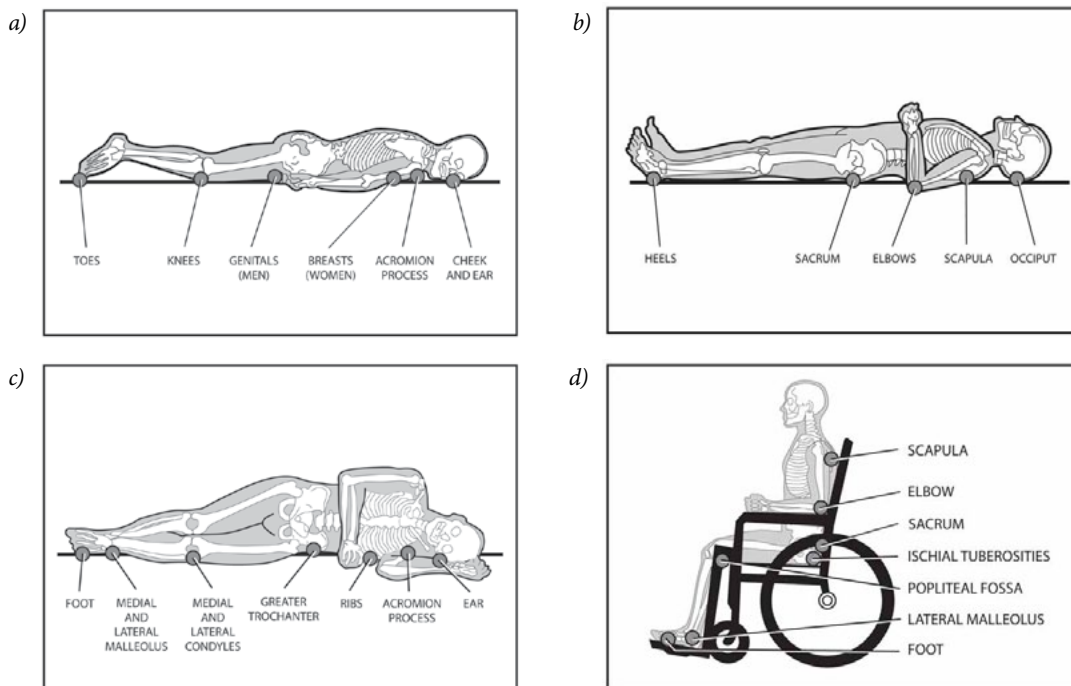



Figure 2. Common sites for pressure ulcers in a) prone, b) supine, c) side-lying, and d) sitting



Few people with spinal cord injury, perform routine skin inspections. The remainder, tend to check their skin only if they identify a problem.

It is critical to investigate reasons for poor or partial adherence to recommendations for skin inspection in order to identify the underlying problem and allow successful resolution. Factors that could potentially be responsible for nonadherence include pain when performing skin checks; competing priorities or trade-offs with other life responsibilities, possibly due to fatigue; psychosocial issues; health issues, such as anemia; or socioeconomic factors, such as inadequate caregiver hours. Only by understanding the problem can the clinician hope to assist the person with spinal cord injury.

PRESSURE-REDISTRIBUTING ACTIVITIES

Commonly taught pressure-redistributing strategies include manual weight shifts, for those with sufficient upper extremity strength and function, and use of wheelchair features, such as tilt and recline.  **CHAPTER 6, *Wheelchairs and other seating, and Chapter 7, Mobility, activity, and conditioning, address these topics.***

Psychosocial factors

INTERACTION BETWEEN PSYCHOSOCIAL FACTORS AND PRESSURE ULCERS

Low quality of life, depressive symptoms, and chronic or unresolved pain, which are common after spinal cord injury, are established predisposing factors for pressure ulcer development. It is important to monitor psychological status in people with spinal cord injury, and when issues are identified, to recognize the relation to increased risk of pressure ulcer. In turn, a pressure ulcer can perpetuate and even worsen low quality of life; depression, anxiety, and other psychological disorders; and pain. A pressure ulcer can also limit a person's ability to participate in meaningful activities through the reduced activity and prolonged bed rest that often accompany pressure ulcer treatment and that reduce quality of life and lead to clinical depression. Clinicians working with people with spinal cord injury and pressure ulcers need to be aware of the self-perpetuating interaction between poor quality of life and conditions associated with pressure ulcer, such as pain and depression, and to implement effective management approaches.

Psychosocial risk factors

Psychosocial factors contribute substantially to pressure ulcer risk by affecting motivation and ability to adhere to essential skin care and pressure management strategies.

QUALITY OF LIFE AFTER SPINAL CORD INJURY

A meta-synthesis of qualitative research on factors associated with quality of life after spinal cord injury identified 10 major concepts⁽¹²⁾:

- Problems associated with an impaired body, including pain and fatigue, and coping with frustration and inconvenience
- Preoccupation with injury and loss, with a life on hold
- Renewed importance of relationships and their role in re-establishing self-worth

- Assuming responsibility and seizing control of one's own life, with decision-making freedom and self-determination
- The importance of occupation, the ability to contribute to others, participation in meaningful activities
- Environmental context, including physical, economic, political, legal, social, and cultural aspects
- Development of new values and perspectives and focus on the deeper meanings of life
- Good days and bad days as a normal part of life
- Rebuilding a sense of self-worth, with competence based on the person, not tied to physical status
- Continuity of biography, with focus on living rather than on impairment

This overview provides healthcare professionals with insight into the experience of quality of life after spinal cord injury. *Research is needed to identify ways in which rehabilitation can best address these issues.*

2.4: Assess quality of life, pain, and depression

Assess the following as part of the comprehensive evaluation of people with spinal cord injury:

RECOMMENDATION LEVEL

- | | |
|-------------------|-----|
| ▪ Quality of life | IV |
| ▪ Pain | III |
| ▪ Depression | III |

Specific rating scales cannot yet be recommended.

RECOMMENDATION LEVEL III–IV

Although several validated quality-of-life measures are available, few apply specifically to the spinal cord injury population. Wood-Dauphinee et al proposed the Reintegration to Normal Living Index, which has been used and validated in studies of people with spinal cord injury.^(13–15) The Cardiff Wound Impact Scale quantifies the effect of a wound on quality of life.⁽¹⁶⁾ As not all items on the scale are relevant to people with spinal cord injury, the scale required modification for use in clinical studies in people with spinal cord injury and pressure ulcers.⁽¹⁷⁾ *No currently available assessment tool is specific to evaluating the impact of pressure ulcer on quality of life in spinal cord injury.*⁽¹⁸⁾  *The section on Rehabilitation practices and associated outcomes following spinal cord injury in SCIRE evaluates several quality of life outcome scales.*⁽¹⁸⁾

PAIN



Chronic pain is an important problem for people with spinal cord injury, and many people experience more than one type of pain, including pain associated with spasticity.

Pain can have a significant impact on mood, function, and quality of life. Accurate characterization of the different types of pain experienced by an individual allows identification of the optimal types of treatment. The impact of pain on functioning is significant. Moderate-to-severe pain can decrease weight-shifting and mobility, ultimately increasing the risk of pressure ulcer development.

Lund et al evaluated the interchangeability of visual analog and verbal rating pain scales according to three pain etiology groups, chronic idiopathic pain, nociceptive pain, and neuropathic pain, in 80 outpatients from a rehabilitation medicine clinic and a spinal cord injury department.⁽¹⁹⁾ The authors found pain intensity assessments were not interchangeable, due to overlapping intensity categories between the two scales, systematic disagreement between the scales, and different meanings of pain intensity according to etiology. The authors concluded that the verbal rating scale was preferred for pain intensity assessment.

Dijkers compared pain severity using a verbal rating scale and a numeric rating scale in 168 people with new spinal cord injury admitted for inpatient rehabilitation.⁽²⁰⁾ Mean numerical ratings showed significant differences for the same adjective on the verbal rating scale when used by different individuals. Not only did individuals use these rating scales differently, but also some understood the adjectives differently from the generally accepted meanings.

Roth et al performed a small pilot study to investigate the comparative clinical value of a unidimensional pain assessment scale, the Numerical Pain Rating Scale, with the more complex multidimensional pain questionnaire, the McGill Pain Questionnaire.⁽²¹⁾ Study participants were 19 men with pain related to chronic wounds; 12 participants had spinal cord injury and pressure ulcers. Measures of pain experience assessed by the McGill Pain Questionnaire were correlated with increasing wound severity and affective distress, whereas the single measure of pain intensity was relatively insensitive in assessing chronic wound pain. The authors suggested that the multidimensional experience of pain may be better assessed by a questionnaire with better sensitivity to these dimensions, such as the multidimensional McGill Pain Questionnaire. *Additional research could improve the understanding of some of the limitations of pain rating scales as outcome measures.*

 *An excellent resource for information about pain is the RNAO best practice guideline, Assessment and management of pain, which is available at http://rnao.ca/sites/rnao-ca/files/Assessment_and_Management_of_Pain.pdf.*

DEPRESSION

Depression is a common finding in people with spinal cord injury, especially in the first few years after injury, and it is appropriate to assess all individuals with spinal cord injury for depression.⁽²¹⁾



Depression has been linked to various negative outcomes in the spinal cord injury population, including poor adjustment, decreased quality of life, and health problems such as pressure ulcers and urinary tract infections.

A longitudinal study investigated changes in the prevalence of depression and the degree of adjustment over a 3-year period in 46 individuals.⁽²²⁾ People were followed for 3 years after discharge from rehabilitation and interviewed at discharge and at 6, 12, 24, and 36 months. Only 34 participants completed the study; one individual withdrew, four died, and seven could not be contacted. Among the people lost to follow-up were a severely depressed individual who withdrew and two people who committed suicide. The study assessed depression using the Center for Epidemiological Studies—Depression (CES-D) Scale, which is reliable in the spinal cord injury population. Symptoms of depression increased shortly after discharge and decreased significantly by 36 months. These data may underestimate the severity of depression, due to the number of participants lost to follow-up. The self-rated adjustment subscale of the Life Situation Questionnaire measured adjustment over the study period. Present adjustment increased over time, whereas predicted adjustment was stable and greater than present adjustment. Lower overall adjustment and the presence of pressure ulcers (both $p = .002$) were significant determinants of depression. A 10-year follow-up is in progress.

A systematic review identified 24 studies reporting psychometric data on measures of depression in people with spinal cord injury.⁽²³⁾ Scales used were the Beck Depression Inventory, CES-D Scale, Older Adult Health and Mood Questionnaire, Zung Self-Rating Depression Scale, Inventory to Diagnose Depression, Patient Health Questionnaire, and Structured Clinical Interview for DSM-IV. Insufficient evidence exists to recommend one tool over another.

 *The section rehabilitation practices and associated outcomes following spinal cord injury in SCIRE summarizes depression screening tools⁽¹⁸⁾.*

PSYCHOSOCIAL IMPAIRMENT

Psychosocial impairment may have an impact on behaviour and skin care practices. Shanmugham et al studied the relation between social problem-solving abilities, health locus-of-control beliefs, and psychosocial impairment in 51 individuals admitted for surgical repair of pressure ulcers.⁽²⁴⁾

The impact of a brief cognitive behavioural intervention was also evaluated. Study participants had greater psychosocial impairment but similar health locus-of-control beliefs compared with a reference sample of people with spinal cord injury. Negative problem-solving orientation significantly predicted psychosocial impairment. Eighteen individuals were randomized to the brief intervention and 33 to the control group. Ten individuals were discharged before completing the scheduled eight-session intervention. No beneficial effects of the intervention could be detected, possibly due to the small sample size, relative insensitivity of the intervention protocol to individual concerns, or other psychosocial factors not studied. Further research to evaluate the efficacy of cognitive-behavioural interventions would be helpful.

PERSONALITY DISORDER

Personality disorders and associated behaviours such as impulsivity, poor social judgment, interpersonal turmoil, and maladaptive coping strategies are seen in some people with spinal cord injury. These behaviours can compromise health status after disability, due to their impact on adherence. Temple and Elliott compared the rate of personality disorder characteristics in people with spinal cord injury undergoing initial rehabilitation with a group that had undergone surgical repair of pressure ulcer.⁽²⁵⁾ They also examined the relation between personality disorder characteristics, psychological reactions, and pressure ulcer occurrence in the rehabilitation sample. Similar proportions of the rehabilitation sample (n=44, 84%) and the pressure ulcer sample (n=20, 90%) demonstrated personality disorder characteristics. Among people in the rehabilitation sample, no difference in personality disorder, depression, or adjustment was seen between people with (n=6) and those without (n=38) pressure ulcers. The small sample size was a study limitation, but the high rate of personality disorder characteristics has implications for clinical practice. These characteristics are associated with distress and poor adjustment, and it appears important for rehabilitation strategies to address these issues to maximize the benefit of rehabilitation.

Correa et al performed a retrospective case-control study to determine risk factors for pressure ulcer in people with spinal cord injury.⁽²⁶⁾ Of 41 cases, 18 had previous pressure ulcer and 23 had no history of pressure ulcer. Univariate analysis found significant risk variables to be longer duration of spinal cord injury, complete injury, paraplegia, thin or obese body type, lack of regular standing practice, and personality disorder. The pressure ulcer risk was 4.3 times higher in people with complete paraplegia than with any other type of injury. People with complete paraplegia who did not practise standing, who had a personality disorder, and who were thin or obese had an even greater pressure ulcer risk.

*Psychosocial interventions***2.5: Psychosocial interventions**

Identify potential psychosocial factors that could increase the risk of pressure ulcers in people with spinal cord injury. Identify the psychosocial impact of pressure ulcers in people with spinal cord injury and pressure ulcers. Refer individuals to appropriate resources for problem resolution, including:

- Vocational rehabilitation services
- Peer counselling and support groups
- Formal psychotherapy and/or family therapy

RECOMMENDATION LEVEL IV



 *Depression following spinal cord injury: a guide for primary care professionals and a lay publication, Depression: what you should know, are available from the Paralyzed Veterans of America (www.pva.org).*

Lifestyle

RISK FACTORS, PREVENTION, AND INTERVENTIONS

For someone with spinal cord injury, much more time and energy are needed to accomplish things we take for granted, like getting dressed. Healthcare professionals can add to the individual's time problems with instructions for pressure management strategies. Many people with spinal cord injury perceive a trade-off between performing pressure-redistributing activities and participating in life. Everything takes longer to accomplish for a person with spinal cord injury, and many feel they simply do not have time for both. Participating in life is the choice they often make.

It is therefore critical for healthcare professionals to consider time constraints when recommending pressure management strategies. A person is more likely to adhere to recommendations if they can be integrated into daily routines and functional activities than performed in isolation. It is also important for the clinician to remember that spinal cord injury is a lifelong problem, and recommendations must be feasible in the long term.

Yang et al used a remote pressure sensor placed in the wheelchair of persons with spinal cord injury to record sitting behaviours and pressure-redistributing activities throughout the day.⁽²⁷⁾ The average daily sitting time was over 9 hours, with a range of 3 to 12 hours, and an average 97 minutes before lift-off behaviour was recorded. This study revealed remarkable profiles of the sitting behaviours of a small group of wheelchair users with paraplegia and tetraplegia living in the community. The study also indicates that community-living people with spinal cord injury who use manual wheelchairs spend prolonged periods of time in their wheelchair each day and engage infrequently in pressure-redistributing activities.

Self-report surveys also reveal low participation in weight-shifting behaviours.^(28,29) Regular pressure-redistributing activities were one of the least frequent health behaviours performed by a group of over 400 community-living people whose duration of spinal cord injury was, on average, 13 years.⁽²⁸⁾ A large survey of 633 individuals with spinal cord injury duration of at least 5 years found no relation between performing skin health behaviours and pressure ulcer history or recurrence of pressure ulcers.⁽²⁹⁾

A qualitative study, using in-depth interviews and observation of 20 individuals with spinal cord injury, examined daily lifestyle influences on pressure ulcer development.⁽³⁰⁾ The information was used to build models of pressure ulcer development, rather than fitting the data into pre-existing hypotheses. These computer models included a balance of liabilities, described as factors increasing risk; and buffers, factors decreasing risk; an individualized risk profile pie chart; and a pressure ulcer event sequence with temporal comprehensiveness.



The most likely situation leading to development of a pressure ulcer involved a disruption of the normal risk equilibrium in an individual with a relatively high-risk profile.

The authors concluded that efforts to prevent pressure ulcers should consider the individual circumstances constituting an individual's daily life that affected the risk profile. Healthcare professionals may be able to design effective interventions by working with people with spinal cord injury to identify and implement individualized risk reduction lifestyle changes that

PRINCIPLES EXPLAINING PRESSURE ULCER DEVELOPMENT

A study of 20 individuals with spinal cord injury and a history of pressure ulcers found the following principles explaining how pressure ulcers developed⁽³¹⁾:

- *Perpetual danger: Even when an individual implements preventive strategies, unforeseen circumstances may trigger pressure ulcer development.*
- *Change or disruption of routine: Development of a pressure ulcer may sometimes be traced to a single change that disrupts the existing risk equilibrium and produces a cascade of events.*
- *Decay of prevention behaviours: Distractions, forgetfulness, and other factors may reduce the frequency of performing prevention techniques, often without the individual even recognizing it.*
- *Lifestyle risk ratio: This is the impact of the sum of physical or lifestyle liabilities, such as poor nutrition and inadequate finances, and buffers, such as a good support system and adherence to preventive strategies.*
- *Individualization: The unique balance of risk and prevention factors at any given time for each person with spinal cord injury determines pressure ulcer development.*
- *Simultaneous presence of prevention awareness and motivation: Long-term prevention knowledge, short-term attention to the situation, and adequate motivation to perform the strategies must all be present to prevent pressure ulcer development.*
- *Lifestyle trade-off: The ways in which an individual balances the needs to engage in personally meaningful activities and to use rest and caution to prevent pressure ulcers change the risk balance.*
- *Access to needed care, service, and supports: The inability to obtain appropriate services, for various reasons, at the time they would be most beneficial or necessary increases pressure ulcer risk.*

are feasible in each person's circumstances. Such interventions would include both standard preventive techniques and solutions to individual issues that could be built into the individual's daily routine and support the person in living a satisfying life while avoiding pressure ulcers.

A qualitative study to identify principles explaining the impact of lifestyle factors on pressure ulcer development used in-depth interviews with a group of 20 adults with spinal cord injury and a history of pressure ulcers.⁽³¹⁾ The study identified several interrelated principles explaining pressure ulcer development (see *Principles explaining pressure ulcer development*).

Clinical lifestyle intervention program

The Lifestyle Redesign Pressure Ulcer Prevention Program (LR-PUP) was developed to incorporate these principles into lifestyle-focused community-based prevention interventions.⁽³²⁾ The LR-PUP interventions were designed to

- Address perpetual danger
- Focus on change or disruption in daily routine that increases pressure ulcer risk
- Respond to changing risk-relevant liabilities in people with spinal cord injury
- Address issues relating to access to resources, care, services, and support

LR-PUP is a 12-month intervention in which a 6-month intensive phase is followed by a 6-month tapered phase. The program is designed with planned personal visits, primarily in the home, and planned phone contacts supplemented by contacts initiated by the individual in response to increased pressure ulcer risk or a developing pressure ulcer. An ongoing randomized controlled clinical trial, the Pressure Ulcer Prevention Study (PUPS-RCT), will eventually enrol 160 people. The study objective is to determine whether the lifestyle intervention reduces the occurrence of stage III and IV pressure ulcers and the need for surgery cost-effectively. The program interventions are contained in a manual and are delivered by an occupational therapist. Intervention sessions are organized as follows:

- Understanding lifestyle and pressure ulcer risk
- Taking charge (advocacy)
- Accessing the physical environment
- Social networks and meaningful relationships
- Happiness and personal well-being
- Planning the future

Each module addresses fixed and variable topics, with the variable topics being addressed based on a participant's needs. Interventions can be tailored (identified interventions customized to individual differences) and individualized (highly person-specific interventions, possibly developed for individual circumstances).

Data on the first 11 participants who were randomized to the intervention were generated from weekly team meetings. Lifestyle-relevant challenges to prevention that were identified include the following:

- *Risk-elevating life circumstances*: such as new immigrants with limited healthcare access or lack of familiarity with the sociocultural environment; expiration of medical coverage; and inebriation of the sole caregiver, preventing access to food, water, and repositioning for a prolonged time
- *Communication difficulties*: including difficulties in contacting participants by telephone, language barriers requiring an interpreter, and passive or aggressive communication styles interfering with communication effectiveness
- *Equipment problems*: frequent difficulties in obtaining needed equipment, need to develop routines to maintain equipment, and backup plans for immediate access to replacement parts or equipment after breakdown
- *Individual personality issues*: factors such as complacency and procrastination, delaying decisions to seek medical help, and impulsive decisions about healthcare providers leading to negative consequences



Effective delivery of community-based rehabilitation interventions required sometimes extreme flexibility on the part of the therapists. Maintaining flexibility in delivering the planned interventions, based on the participants' most urgent needs, included changing the order, content, or approach of the interventions, or adding situation-specific interventions to deal with crises

The study is ongoing, but key clinical implications have already been identified. Interventions must be relatively intensive and flexible to address individual issues, and community-based pressure ulcer prevention efforts are greatly needed to address risk factors.

Beliefs and behaviours

When developing interventions to improve pressure ulcer prevention practices, it is important to understand how beliefs and attitudes are related to behaviour.

BELIEFS

Skin care beliefs

A qualitative interview study was performed in 22 people with spinal cord injury to identify their skin care beliefs.⁽³³⁾ Study participants generally believed the following:

- Pressure ulcers had serious consequences.
- They were susceptible to developing pressure ulcers.
- They could perform the necessary skin care.
- They could prevent a pressure ulcer.



Four main themes of beliefs emerged:

- **Taking vigilant care:** need for preventive skin care, ensuring it occurred
- **Taking charge of care:** training helpers, using equipment, fitting care into daily life
- **Maintaining health:** maintaining mental and physical health, including skin integrity
- **Passing up care:** barriers to care and impact on life, care routines, misconceptions, ambivalence about care, and competing priorities

Many participants believed a healthy lifestyle reduced pressure ulcers, skin care was necessary to health, and skin care allowed participation in activities.



Positioning skin care as a health maintenance activity could decrease barriers and increase adherence for some individuals.

Despite beliefs about the importance of skin care, many participants were inconsistent in their practices. Factors involved included embarrassment about performing pressure-redistributing movements in public, the desire to feel normal, scepticism about the necessity of skin care, and competing priorities. In addition, only half of the participants took charge of their skin care, with the others either delegating it to caregivers or abandoning it.

Implications for practice involve both rehabilitation and community phases. These include increasing motivation to perform skin care by promoting ownership of skin care practices, involving family members in supporting the person, emphasizing the value of skin care, addressing barriers, evaluating beliefs and practices, and providing feedback on an ongoing basis during follow-up visits.

Pressure ulcer experience

Langemo et al conducted interviews with eight individuals about their experience of having a pressure ulcer and what it meant to them; four individuals had an ulcer at the time of the interview and four had had an ulcer previously.⁽³⁴⁾ Participants included four individuals with spinal cord injury. The investigators organized the different aspects of the pressure ulcer experience into themes (see Significant impact of pressure ulcer experience).

Significant impact of pressure ulcer experience

The following themes emerged from the study:

- **Etiology of the ulcer:** participants believed that the ulcer was due either to poor care or to their own neglect
- **Impact on life:** difficulty associated with mandatory bed rest and immobility, social isolation, and financial impact
- **Psychospiritual impact:** body image changes, due to loss of a large amount of tissue and problems with lack of privacy during procedures; struggles coping with 'handicapped' stereotypes; desire to regain control over their lives and struggle for independence; spiritual impact of health crisis and support from religious beliefs
- **Severe pain:** intensity compared to being stabbed, to burning or stinging; almost constant pain, even a problem after healing of ulcer; analgesic use concerns, including concerns about addiction and reluctance to take medications
- **Need for knowledge and understanding of pressure ulcers:** knowledge of prevention, including skin checks and pressure-redistributing movements; knowledge of physiologic processes such as wound healing; and lack of knowledge and confusion of pressure ulcer with gastric ulcer
- **Need for many stressful treatments:** self-care knowledge after several pressure ulcers; treatment regimens including bed rest and surgical interventions such as debridement and flap repair; complications, including life-threatening sepsis; frustrating length of healing time

- *Grieving process: pressure ulcer in people with spinal cord injury associated with stages of grief, including denial, depression, anger, and acceptance*

The researchers concluded that pressure ulcers had a profound impact on the individuals who experienced them. [key point icon] Individuals who developed pressure ulcers generally had significant needs for knowledge about self-care practices and pressure ulcer prevention.

BEHAVIOURS

Testing the theory of planned behaviour

The theory of planned behaviour suggests the most important determinant of behaviour is intention, which is influenced by the following:

- **Attitude:** the belief that the behaviour will have the desired result
- **Subjective norm:** a strong desire to comply with the opinion of people important to the individual, who will approve of the behaviour
- **Perceived control:** the perceived resources to perform the behaviour

A within-group cross-sectional survey was performed to evaluate the applicability of the theory of planned behaviour to preventive skin care in the spinal cord injury population.⁽³⁵⁾ Knowledge of skin care behaviour and mood were also assessed. Participants in the main survey were 59 people with spinal cord injury; 17 of these individuals completed test–retest questionnaires. Since discharge, 29 participants had experienced a pressure ulcer. The study found that intention to perform skin checks or pressure-redistributing movements significantly predicted the behaviour, but not the development, of pressure ulcers. Knowledge of skin care reduced the occurrence of pressure ulcers ($p < .01$). Anxiety, depression, and lack of skin care knowledge all predicted occurrence of pressure ulcers.



Clinical implications of this study are the following:

- Knowledge of skin tolerance to pressure is linked to the intention to perform pressure-redistributing movements. This indicates that evaluation using a 24-hour approach to pressure ulcer prevention would be helpful to people with spinal cord injury to determine individual safe sitting time. In addition, reviewing skin care education at all appointments could provide beneficial educational refreshers.
- The opinions of individuals with importance to the person with spinal cord injury can influence compliance with skin care instructions. Education of family members could support and motivate the person with spinal cord injury.

Pressure ulcer prevention behaviours

Jones et al conducted a telephone and mail survey of 86 individuals 6 to 17 years after spinal cord injury, focusing on self-care habits of people with healthy skin histories ($n=45$) in comparison with those with frequent pressure ulcers ($n=41$).⁽³⁶⁾ Several statistically significant between-group differences were identified (see Important preventive behaviours), and it is important for clinicians to be aware of these behaviours.

People with healthy skin histories were more likely to⁽³⁵⁾

- Weigh less
- Consume less alcohol
- Perform more wheelchair transfers daily
- Be female
- Have more sensation below the level of injury.
- Be employed
- Be non-smokers
- Have fewer incontinence problems
- Be more active

The findings of this preliminary study indicate pressure ulcer prevention behaviours are associated with general health behaviours, and education to prevent pressure ulcers should include overall health behaviours.

Krause and Broderick performed a mail survey to identify factors associated with pressure ulcer recurrence.⁽²⁹⁾ Of the 826 participants, 633 reported a pressure ulcer history that could be classified according to presence (13%) or absence (70%) of recurrent pressure ulcers. Logistic regression associated several general lifestyle, exercise, and diet behaviours with absence of recurrent pressure ulcers. The preventive behaviours recommended during rehabilitation, skin checks and weight shifts were not associated with pressure ulcer history. Risk behaviours identified were number of cigarettes smoked and use of medication for sleep. The authors concluded that a healthy lifestyle is strongly associated with pressure ulcer prevention, whereas the benefit of specific prevention behaviours was not demonstrated. *They also concluded that problem solving and coping strategies should be targets for further research.*

Bloemen-Vrencken et al performed a mail survey to describe health behaviours of persons with spinal cord injury and identify any relation to individual or injury characteristics, secondary impairments, readmissions to rehabilitation, and perceived health.⁽²⁸⁾ The frequency of health behaviours varied considerably. Importantly, the survey found that pressure-redistributing movements were not performed frequently during the time spent in a wheelchair, although the importance of pressure relief practices is emphasized during rehabilitation. The frequency of health behaviours increased with increasing age and in the presence of secondary impairments. Pressure ulcer preventive behaviours were more frequent in individuals with complete lesions. *As education on pressure ulcer prevention is a central part of rehabilitation, it is important to evaluate the effectiveness of behaviours promoted during the rehabilitation phase post spinal cord injury.*

Behavioural responses to pressure ulcer

People who detect a pressure ulcer may respond in a variety of ways, depending on lifestyle considerations.⁽¹¹⁾ Dunn et al analyzed personal information profiles to identify factors affecting responses to detecting low-grade pressure ulcers. The analysis included 46 pressure ulcers in 19 people. Responses were organized into the following categories:

- **Lacking adequate knowledge:** inability to identify an ulcer, take the proper steps, or understand the risks
- **Procrastinating:** delays in seeking medical attention due to fear of hospitalization or surgery or as a result of denial
- **Experiencing cognitive dysfunction:** inadequate responses reflecting cognitive impairment due to brain injury or behavioural impairment due to depression
- **Diverting attention:** decisions to address other physical concerns felt to be more urgent, such as incontinence, or activities thought to be more important, such as work
- **Avoiding social discomfort:** reluctance to comply with treatment instructions felt to be embarrassing, such as wearing a sock on an ulcerated foot rather than 'proper footwear,' or not hiring a helper because it was 'undignified'
- **Being thwarted in receiving adequate medical help:** a variety of factors resulted in improper medical care, including inadequately trained or motivated healthcare providers, institutional barriers to care, and inability to reach healthcare professionals by telephone
- **Relying on self or caregiver help:** attempts to heal pressure ulcers without obtaining medical care
- **Adhering to medical recommendations:** following apparently sound advice from a healthcare professional

In all categories, pressure ulcers worsened. The implications for practice are numerous. Lifestyle considerations strongly influence health behaviours, so individualized preventive education and interventions should be combined with structured follow-up that considers the individual's unique concerns and lifestyle. *Clearly, people's lifestyle choices and behaviours are key determinants of the outcomes of treatment strategies. Research is needed to determine why some individuals adhere to prevention and treatment programs.*



Education and behaviour change

INTERVENTIONS

Education

2.6: Ongoing structured education

Provide individuals who have spinal cord injury, their families, significant others, and healthcare professionals with structured education about effective strategies for the prevention and treatment of pressure ulcers. Be sure to deliver education at a grade 3 to 6 level using a variety of methods.

RECOMMENDATION LEVEL III



2.7: Individualize education

Provide education specific to the individual after each assessment and reassessment. This education should include:

- Potential causes and risks of pressure ulcer development
- Methods of self-monitoring
- Reduction of pressure ulcer risks as part of the prevention plan

RECOMMENDATION LEVEL III



EVIDENCE

Comprehensive education about pressure management can reduce pressure ulcer occurrence and recurrence. It is important that people with spinal cord injury and their families understand their responsibilities in the area of pressure ulcer prevention.⁽³⁷⁾ Enhanced education has been shown to help people with spinal cord injury develop and retain the necessary knowledge, but an accompanying decrease in pressure ulcer incidence has not been demonstrated.

In today's healthcare environment, hospital stays are shorter and the focus of care is attaining the greatest functional gains in activities of daily living and mobility before discharge.⁽¹⁾ Although education may not always receive the attention it deserves, both the individual with the injury and caregivers, including family members, have a critical need for pressure ulcer prevention education. As an example, during acute care people with spinal cord injury and family members need to know the importance of frequent turning in bed and ensure that the appropriate health care professional is called if the individual has not been turned recently.



Educational materials must be written at a grade 3 to grade 6 level. A recent study from Statistics Canada and the Organisation for Economic Cooperation and Development found 40% of Canadians struggle with low literacy.⁽³⁸⁾

Essential components of education include daily routine health behaviours such as skin inspection, pressure redistribution, and nutrition. It is important for healthcare providers to assess the level of knowledge and understanding of recommended behaviours and to implement systematic education about prevention. A person's recollection of education may be poor, so the clinician must identify signs indicating poor recall and use this information to reinforce education. Peer influence may be an important influence on retention of information, so peer programs can support other educational efforts.

Thietje et al conducted a single-centre prospective cohort study to investigate how people with spinal cord injury learned about bladder management and pressure ulcers.⁽³⁷⁾ Data were collected on 214 consecutive people with spinal cord injury at admission to the centre, at 1 and 3 months after admission, and at 6, 18, and 30 months after discharge. They were discharged 3 to 6 months after admission. Knowledge about these complications was tested using the Knowledge Score, which has values ranging between 0 and 20. Scores were classified into poor (0–8), average (9–12), and good (13–20) knowledge. Mean Knowledge Scores increased from 5.4 on admission to 11.2 at discharge ($p < .001$). Fewer than 50% of participants had good knowledge about bladder management and pressure ulcers at discharge. At 30 months after discharge, the mean score decreased to 10.8 points. Overall, participants older than 65 years had less knowledge than younger subjects ($p < .001$). A lower education level has also been found to be a pressure ulcer risk factor in individuals with traumatic spinal cord injury.⁽³⁹⁾

Behaviour-contingent structured education

Two small studies evaluated the effectiveness of an intervention with monetary rewards as a consequence for preventing or reducing the severity of pressure ulcers in people with spinal cord injury and a history of recurrent ulcers.⁽⁴⁰⁾ In the first study, six individuals began a comprehensive self-care plan with a schedule of visits by an advanced practice nurse and monetary rewards for successfully preventing serious pressure ulcers. Pressure ulcer severity and treatment costs decreased for the participants, with three participants demonstrating long-term improvement. In the second study, three participants began a comprehensive self-care plan with a schedule of visits by an advanced practice nurse. Monetary rewards were staged so that analysis could compare the effectiveness of visits alone to visits plus monetary rewards. Visits alone did not reduce pressure ulcer severity for two of the three participants, but visits plus payments were effective. These small studies support the assumption that pressure ulcer recurrence may be related to insufficient positive consequences for effective prevention. *Research is needed to develop more effective behaviour-contingent education strategies.*

Structured education and follow-up

Rintala et al performed a randomized controlled trial with 41 veterans with spinal cord injury admitted for surgical repair of a pressure ulcer.⁽⁴¹⁾ Group 1 ($n=20$) received individualized education and monthly telephone follow-up; group 2 ($n=11$) received monthly mail or telephone follow-up without education; and group 3 ($n=10$) received quarterly mail or telephone follow-up without education. Group 1 had a significantly longer time to pressure ulcer recurrence (19.6 months, $p = .002$) and a lower recurrence rate (33%, $p = .007$) than group 2 (10.1 months, 60%) or group 3 (10.3 months, 90%). Exploratory analysis found the intervention was not effective for individuals who had had previous pressure ulcer surgery. Possible conclusions to be drawn are that people admitted for their first pressure ulcer surgery should receive individualized education and follow-up, and people with previous pressure ulcer surgery may require more intensive intervention.



Risk assessment and feedback

A computerized risk assessment feedback tool and consultation package, the Risk Instrument for Secondary Conditions (RISC), was developed and tested in two people with spinal cord injury to determine whether RISC could promote weight-shifting to reduce pressure ulcers and fluid intake to decrease urinary tract infection.⁽⁴²⁾ The investigation also included a knowledge assessment of selected secondary conditions, including the topics under study. Both participants had experienced pressure ulcers and urinary tract infections. As part of the intervention, they received printed feedback on their risk levels at baseline. Both participants improved their knowledge, increased the weight-shifting frequency, and decreased urine-specific gravity. The intervention had a modest effect on behaviour. This computer-based intervention provides an opportunity to modify health-related behaviours. Additional research to validate the results and investigate maintenance of behaviour change would be useful.

Rowland et al conducted a prospective randomized study to analyze the effectiveness of an Internet assessment tool (RISC) and individualized feedback strategy in assessing pressure ulcer risk.⁽⁴³⁾ Study participants were 71 people with newly diagnosed spinal cord injury who were treated at a Model Spinal Cord Injury Systems Center. The experimental group received computerized feedback followed by individual telephone consultations to address risk behaviours identified in their online knowledge and behavioural questionnaire responses, whereas the control group received no feedback until study completion, a year later. At that time, the online questionnaire was re-administered as a post-test. Researchers administered phone surveys about the development of secondary conditions three times during the study. Mean knowledge score differences for pressure ulcer prevention approached significance, but the difference did not translate into a decrease in pressure ulcers in the experimental group. Individual contact may have been inadequate to promote risk reduction.

In this study, the tool demonstrated neither the sensitivity to differentiate risk levels among the participants nor an impact on pressure ulcer prevention. Nevertheless, this type of technology, with individualized feedback, could potentially lead to the development of stronger community-based prevention efforts.

Self-Management

2.8: Promote self-management

Promote self-management for people with spinal cord injury. Help them learn, consistently apply, and incorporate into their daily lives effective and appropriate pressure ulcer prevention strategies.

RECOMMENDATION LEVEL IV



CONCEPTS AND APPROACHES

Self-management and decision support are integral components of chronic disease management.⁽⁴⁴⁾ People with spinal cord injury and their families want to be involved in decision-making and have their views and preferences heard. In addition, professional standards of practice and guidelines call for consumer inclusion in care planning. Living well with a chronic condition requires knowledge and confidence to manage the condition. Numerous approaches to self-management exist, and basic strategies include the following:

- Addressing behavioural risk factors and implementing support systems
- Monitoring and managing disease signs and symptoms

- Practising health behaviours
- Adhering to medication use
- Maintaining regular contact with healthcare providers

5-A conceptual framework

The 5-A conceptual framework for delivering and evaluating behavioural counselling interventions uses the strategies of assess, advise, agree, assist, and arrange (see 5-A framework).⁽⁴⁵⁾

- Assess:
 - » Beliefs: Do they believe they can influence change?
 - » Behaviour: Assess for depression and treat if necessary.
 - » Knowledge
- Advise: Provide specific information about health risks and benefits of change.
- Agree: Set goals in collaboration with the person, based on the individual's interest and confidence in his or her ability to change the behaviour.
- Assist: Identify personal barriers, strategies, problem-solving techniques, and social and environmental support.
- Arrange: Specify a follow-up plan, including visits, phone calls, and mailed reminders.

The person with spinal cord injury develops a personal action plan, using the following approach:

- List specific goals in behavioural terms.
- Identify and list barriers to achieving the goals and strategies to address the barriers.
- Specify a follow-up plan.
- Share the plan with the practice team and the person's social supports.
- Consider SCI-U (see page "SCI-U" on page 44), an e-learning program for people with spinal cord injury.

The framework incorporates multiple self-management strategies to support people with one or more chronic conditions to improve outcomes. The United States Preventive Services Task Force Counseling and Behavioral Interventions Work Group recommends using the 5-A conceptual framework to evaluate and describe health behaviour counselling interventions. Evidence supports each component of the framework. The 5-A framework has been used for health behaviour interventions and the self-management component of chronic disease management. It has not yet been evaluated in spinal cord injury.

Skin Management needs assessment checklist

The Skin Management needs assessment checklist (SMnac) assesses the ability of individuals with spinal cord injury to perform skin checks and pressure-redistributing movements and helps equip them with the necessary skills to prevent pressure ulcer development. Berry et al evaluated the internal consistency of the SMnac in 317 participants during inpatient rehabilitation.⁽⁴⁶⁾ The authors also evaluated its sensitivity to change in a subset of 187 people who completed a second checklist approximately 6 weeks before discharge from rehabilitation. Analysis found high internal consistency and sensitivity to change. The SMnac indicates specific problems and standardizes inputs to meet rehabilitation targets, measuring the effect of interventions. Use of this checklist could contribute to reducing the incidence of pressure ulcers in people with spinal cord injury.

Peer support

Peer support can be a critical factor in education and adherence. A community-based peer outreach program was conceptualized and implemented as a way of providing education about pressure ulcer prevention in a manner compatible with individual learning styles, outside the traditional medical model.⁽⁴⁷⁾ The Peer Information Network was an evaluation project of peer support. It trained 24 peer advisors and operated through community centres that provided services to promote independence for people living with disabilities. The primary objectives were to decrease pressure ulcer incidence by 20% and reduce ulcer severity over a 12-month period in the intervention group compared with the control group. A secondary objective was to examine the relation between psychosocial factors and pressure ulcer incidence.

The study recruited 56 individuals with spinal cord injury and a high risk of pressure ulcers and randomized them to participation in the Peer Information Network or a control group. An initial interview collected comprehensive baseline information. During the 12-month follow-up, participants completed a diary for each pressure ulcer occurrence. A second interview was conducted at the end of the follow-up period. Each person in the intervention group was matched with a peer advisor who was provided with information on pressure ulcer prevention determined by the participant's knowledge level. The peer advisor was asked to cover these topics in the course of a recommended series of eight visits during the study.

At the end of the study, the intervention was associated with only a 5% decrease in pressure ulcer incidence, and pressure ulcer severity was similar in both groups. The intervention group had greater improvement in knowledge of pressure ulcer prevention than the control group. The control group had an adjusted odds ratio of 3.04 for multiple pressure ulcers compared with the intervention group. In the intervention group, eight subjects were lost to follow-up for various reasons, and one participant reported 10 pressure ulcers, which affected the analysis. Study participants rated their experience as highly positive.

The study encountered numerous implementation difficulties, including low recruitment, high loss to follow-up of intervention subjects, and lack of control over peer advisor training and interventions. Nevertheless, an important strength of the project was the development of a community-based intervention that could continue to operate independently and provide a framework empowering individuals to become involved in pressure ulcer prevention and management of their own health.

Perceptions of pressure ulcer prevention

It is helpful for healthcare professionals working with spinal cord-injured individuals to understand their perceptions of pressure ulcer prevention. To this end, a descriptive interview study explored the attitudes to pressure ulcer prevention of a young group and examined the impact of their understanding and perception on the maintenance of skin integrity.⁽⁴⁸⁾ Interviews were conducted with 10 people with paraplegia of less than 3 years' duration. All study participants had an understanding of pressure ulcer causes and prevention. Nine participants completed an education program about pressure ulcers, which created a strong motivation for skin checks and pressure-redistributing movements, as they were adamant about avoiding bed rest for pressure ulcer management. The use of shock tactics about the need for bed rest if a pressure ulcer develops can, however, be counterproductive, as individuals may become obsessive about pressure-relieving movements. After discharge from rehabilitation, participants tended to become more lax about performing skin checks. When they identified developing problems, however, they become much more attentive to pressure management.

Educational needs

Schubart et al used a needs assessment methodology to investigate the educational needs of individuals with spinal cord injury.⁽⁴⁹⁾ Interviews with 16 adults with spinal cord injury and eight spinal cord injury healthcare professionals gathered information about pressure ulcer prevention and early detection.

The most important educational needs identified related to self-management issues were

- Ensuring people with spinal cord injury and their caregivers understand individual lifelong pressure ulcer risk, the potential for serious or life-threatening consequences, and the importance of self-assessing risk and identifying changes over time
- Taking charge of their own skin care and feeling empowered to partner with their healthcare team
- Developing preventive strategies that fit their functional and activity levels, implementing them consistently, and addressing the need for changes as risk levels change
- Developing strategies for coordinating social supports for family and paid caregiving situations

Research is needed to determine the specific education required for individuals with spinal cord injury to reduce the risk of pressure ulcer formation and to determine the effect of such education on reduction of the incidence of pressure ulcers and on development of complications.



SELF-MANAGEMENT PROGRAMS

Several self-management programs to support people in preventing and treating pressure ulcers have been developed and are available from organizations such as the RNAO, the Ontario Neurotrauma Foundation, and the Canadian Paraplegic Association.

Registered Nurses' Association of Ontario

 The RNAO has developed a best practice guideline, Strategies to support self-management in chronic conditions: collaboration with clients, which is available at http://rnao.ca/sites/rnao-ca/files/Strategies_to_Support_Self-Management_in_Chronic_Conditions_-_Collaboration_with_Clients.pdf. The guideline provides evidence-based recommendations across the continuum of care in self-management support and identifies strategies and interventions to enhance people's ability to manage chronic health conditions.

British Columbia Paraplegic Association Provincial Peer Program

 The British Columbia Paraplegic Association Provincial Peer Program has a goal of providing educational opportunities and social connections for people with spinal cord injury, their family members, and their friends. The program includes peer matching and mentoring, group sessions, telehealth education, a variety of information sources including a magazine, and several offices. Information is available at <http://sci-bc.ca/we-can-help/peer-program/>

SCI-U

 The Ontario Neurotrauma Foundation is leading and supporting self-management as a fundamental tool for people with spinal cord injury. SCI-U is a best-practice e-learning education program that originated at Stanford University. It is currently being developed for spinal cord injury with several partners, including the Ontario Neurotrauma Foundation. The program, Taking charge of your health, taking care of yourself, is based on the principles and elements of the Stanford model and reflects the need to ensure the individual with the condition is the central decision-maker. SCI-U includes a step-by-step process for pressure ulcer prevention and will be available at <http://blog.sci-u.ca/?p=180>.

SpinalCordConnections.ca

 This new, innovative Canadian e-resource centre (www.spinalcordconnections.ca) for people with spinal cord injury, their families, and community-based healthcare and service providers gives access to up-to-date, reliable information about spinal cord injury and connections to people in the spinal cord community.

Spinal Cord Injury Solutions Alliance

👁️ The Hamilton Niagara Haldimand Brant Spinal Cord Injury Solutions Alliance is one of several networks of stakeholders that are addressing systemic barriers, ensuring best-practice implementation, and tailoring solutions to improve services and quality of life. Early and integrated involvement of regional service coordinators and peer support in acute care and rehabilitation teams is an important component of the model system. Other components are implementing self-management education as soon as the person is medically stable and connecting every person with spinal cord injury and his or her family with a peer support volunteer during acute care. This is similar to the 'system navigator' concept, where one person guides the individual with spinal cord injury throughout the continuum of care to ensure the person and family have the right information at the right time to promote independence and self-reliance.

INFORMATION SOURCES FOR PEOPLE WITH SPINAL CORD INJURY

👁️ Several associations provide lay information on pressure ulcers, much of it designed for people with spinal cord injury. The following are examples:

- **State Government Victoria, Australia, Department of health**

<http://www.health.vic.gov.au/pressureulcers/downloads/ppu/english.pdf>

- **Pressure ulcers: What you should know.** A guide for people with spinal cord injury: a 48-page guide available from numerous sources including the website of the Consortium for Spinal Cord Medicine at www.scicpg.org.

CONCLUSION

The development of any education or self-management strategies to prevent pressure ulcers must consider the entire person, lifestyle and associated risks, knowledge, psychosocial factors, and overall health behaviours. Changes in daily routine necessitated by other health conditions or lifestyle changes are a time of high pressure ulcer risk.

The optimal approach to preventing pressure ulcers has not yet been identified, and significant research may be required to develop effective interventions. It is, however, likely that the most effective interventions will be holistic, intensive, and individualized.

REFERENCES

1. Consortium for Spinal Cord Medicine Clinical Practice Guidelines. Pressure ulcer prevention and treatment following spinal cord injury: a clinical practice guideline for health-care professionals. *J Spinal Cord Med* 2001;24(Suppl 1):S40–101.
2. Rodriguez GP, Claus-Walker J. Biomechanical changes in skin composition in spinal cord injury: a possible contribution to decubitus ulcers. *Paraplegia* 1988;26:302–9.
3. Rodriguez GP, Markowski J. Changes in skin morphology and its relationship to pressure ulcer incidence in spinal cord injury. *Arch Phys Med Rehabil* 1995;76:593.
4. Pilonchery G, Minaire P, Milan JJ, Revol A. Urinary elimination of glycosaminoglycans during the immobilization osteoporosis of spinal cord injury patients. *Clin Orthop* 1983;174:230–5.
5. Singh J, Diferrante N, Strashun MF, Gyorkey F. Urinary excretion of glycosaminoglycans in quadriplegia: Proceedings of the Society of Experimental Biological Medicine 1977;156:488–90. [Abstract].
6. Rodriguez GP, Claus-Walker J, Kent MC, Stal S. Adrenergic receptors in insensitive skin of spinal cord injury patients. *Arch Phys Med Rehabil* 1986;67:177–80.
7. Registered Nurses' Association of Ontario. Nursing best practice guideline: Assessment & Management of Stage I to IV Pressure Ulcers 2011. Available at <http://www.rnao.org/bestpractices>. Accessed November 20, 2011.
8. European Pressure Ulcer Advisory Panel and National Pressure Ulcer Advisory Panel. Pressure ulcer prevention: quick reference guide. Washington, DC: National Pressure Ulcer Advisory Panel; 2009. Available at http://www.epuap.org/guidelines/Final_Quick_Prevention.pdf. Accessed November 20, 2011.
9. Dunn R, Stander J. Pressure sores in spinal cord injury: active intervention saves costs. *SAJCC* 2008;24:8–12.
10. Ahn H, Singh J, Nathens A, MacDonald R, Travers A, Tallon J, et al. Pre-hospital care management of a potential spinal cord injured patient: a systematic review of the literature and evidence-based guidelines. *J Neurotrauma* 2011;28:1341–61.
11. Dunn CA, Carlson M, Jackson JM, Clark FA. Response factors surrounding progression of pressure ulcers in community-residing adults with spinal cord injury. *Am J Occup Ther* 2009;63:301–9.
12. Hammell WK. Quality of life after spinal cord injury: a meta-synthesis of qualitative findings. *Spinal Cord* 2007;45:124–39.
13. Wood-Dauphinee SL, Opzoomer MA, Williams JL, Marchand B, Spitzer WO. Assessment of global function: the Reintegration to Normal Living Index. *Arch Phys Med Rehabil* 1988;69:583–90.
14. Hitzig SL, Escobar MR, Noreau L, Craven BC. Validation of the reintegration to normal living index for community-dwelling persons with chronic spinal cord injury. *Arch Phys Med Rehabil* 2012;93:108–14.
15. Hitzig SL, Tonack M, Campbell KA, McGillvray CF, Boschen KA, Richards K, Craven BC. Secondary health complications in an aging Canadian spinal cord injury sample. *Am J Phys Med Rehabil* 2008;87:545–55.
16. Houghton, PE, Campbell KE, Fraser CH, Harris C, Keast DH, Potter PJ, et al. Electrical stimulation therapy increases rate of healing of pressure ulcers in community dwelling people with spinal cord injury. *Arch Phys Med Rehabil* 2010;91:669–78.
17. Price P, Harding K. Cardiff Wound Impact Schedule: the development of a condition specific questionnaire to assess health related quality of life in patients with chronic wounds of the lower limb. *Int Wound J* 2004;1:10–6.
18. Wolfe DL, Hsieh JTC, Mehta S. Rehabilitation practices and associated outcomes following spinal cord injury. In: Eng JJ, Teasell RW, Miller WC, Wolfe DL, Townson AF, Hsieh JTC, et al, eds. *Spinal Cord Injury Rehabilitation Evidence*, 2010. Version 3.0. Available at <http://www.scireproject.com/>. Accessed November 20, 2011.
19. Lund I, Lundeberg T, Sandberg L, Budh CN, Kowalski J, Svensson E. Lack of interchangeability between visual analogue and verbal rating pain scales: a cross sectional description of pain etiology groups. *BMC Med Res Methodol* 2005;5:31.
20. Dijkers M. Comparing quantification of pain severity by verbal rating and numeric rating scales. *J Spinal Cord Med* 2010;33:232–42.
21. Roth RS, Lowery JC, Hamill JB. Assessing persistent pain and its relation to affective distress, depressive symptoms, and pain catastrophizing in patients with chronic wounds. *Am J Phys Med Rehabil* 2004;83:827–34.
22. Dorsett P, Geraghty T. Depression and adjustment after spinal cord injury: a three-year longitudinal study. *Top Spinal Cord Inj Rehabil* 2004;9:43–56.
23. Kalpakjian C, Bombardier C, Schomer K, Brown P, Johnson K. Measuring depression in persons with spinal cord injury: a systematic review. *J Spinal Cord Med* 2008;31:47–65.
24. Shanmugham K, Elliott TR, Palmatier A. Social problem solving abilities and psychosocial impairment among individuals recuperating from surgical repair for severe pressure sores. *NeuroRehabilitation* 2004;19:259–69.

25. Temple RO, Elliott TR. Personality disorder characteristics and adjustment following spinal cord injury. *Top Spinal Cord Inj Rehabil* 2000;6:54–65.
26. Correa GI, Fuentes M, Gonzalez X, Cumsille F, Pineros JL, Finkelstein J. Predictive factors for pressure ulcers in the ambulatory stage of spinal cord injury patients. *Spinal Cord* 2006;44:734–9.
27. Yang Y-S, Chang G-L, Hsu M-J, Chang J-J. Remote monitoring of sitting behaviours for community-dwelling manual wheelchair users with spinal cord injury. *Spinal Cord* 2009;47:67–71.
28. Bloemen-Vrencken JHA, de Witte LP, Post MWM, van den Heuvel WJA. Health behaviour of persons with spinal cord injury. *Spinal Cord* 2007;45:243–9.
29. Krause JS, Broderick L. Patterns of recurrent pressure ulcers after spinal cord injury: identification of risk and protective factors 5 or more years after onset. *Arch Phys Med Rehabil* 2004;85:1257–64.
30. Clark FA, Jackson JM, Scott MD, Carlson ME, Atkins MS, Uhles-Tanaka D, Rubayi S. Data-based models of how pressure ulcers develop in daily-living contexts of adults with spinal cord injury. *Arch Phys Med Rehabil* 2006;87:1516–24.
31. Jackson J, Carlson M, Rubayi S, Scott MD, Atkins MS, Blanche EI, et al. Qualitative study of principles pertaining to lifestyle and pressure ulcer risk in adults with spinal cord injury. *Disabil Rehabil* 2010;32:567–78.
32. Vaishampayan A, Clark F, Carlson M, Blanche EI. Preventing pressure ulcers in people with spinal cord injury: targeting risky life circumstances through community-based interventions. *Adv Skin Wound Care* 2011;24:275–84.
33. King RB, Porter SL, Vertiz KB. Preventive skin care beliefs of people with spinal cord injury. *Rehabil Nurs* 2008;33:154–62.
34. Langemo DK, Melland H, Hanson D, Olson B, Hunter, S. The lived experience of having a pressure ulcer: a qualitative analysis. *Adv Skin Wound Care* 2000;15: 225–35.
35. Sheppard R, Kennedy P, Mackey CA. Theory of planned behaviour, skin care and pressure sores following spinal cord injury. *J Clin Psychol Med Settings* 2006;13:359–67.
36. Jones ML, Marini I, Slate JR. Prevention practice differences among persons with spinal cord injuries who rarely versus frequently sustain pressure ulcers. *Rehabil Couns Bull* 2005;48:139–45.
37. Thietje R, Giese R, Pouw M, Kaphengst C, Hosman A, Kienast B, et al. How does knowledge about spinal-cord injury-related complications develop in subjects with spinal cord injury? A descriptive analysis in 214 patients. *Spinal Cord* 2011;49:43–8.
38. Desjardins R, Murray S, Clermont Y, Werquin P. 2003. Learning a Living: First Results of the Adult Literacy and Life Skills Survey. Statistics Canada and the Organisation for Economic Co-operation and Development (OECD). Available at <http://www5.statcan.gc.ca/bsoic/olc-cel/olc-cel?catno=89-603-XWE&lang=eng>. Accessed November 20, 2011.
39. Taghipoor KD, Arejan RH, Rasouli MR, Saadat S, Moghadam M, Vaccaro R, Rahimi-Movaghar V. Factors associated with pressure ulcers in patients with complete or sensory-only preserved spinal cord injury: is there any difference between traumatic and nontraumatic causes? *J Neurosurg Spine* 2009;11:438–44.
40. Jones ML, Mathewson CS, Adkins VK, Ayllon T. Use of behavioral contingencies to promote prevention of recurrent pressure ulcers. *Arch Phys Med Rehabil* 2003;84:796–802.
41. Rintala DH, Garber SL, Friedman JD, Homes SA. Preventing recurrent pressure ulcers in veterans with spinal cord injury: impact of a structured education and follow-up intervention. *Arch Phys Med Rehabil* 2008;89:1429–41.
42. Wyatt DA, White GW. Reducing secondary conditions for spinal-cord-injured patients: pilot testing a risk assessment and feedback instrument. *Top Spinal Cord Inj Rehabil* 2000;6:9–22.
43. Rowland JL, White GW, Wyatt DA. Analysis of an intervention to reduce or prevent secondary conditions for people with spinal cord injuries. *J Clin Psychol Med Settings* 2006;13:263–71.
44. Registered Nurses' Association of Ontario. Strategies to Support Self-Management in Chronic Conditions: Collaboration with Clients. Toronto, Canada; 2010. Registered Nurses' Association of Ontario.
45. Goldstein M, Whitlock E, DePue J. Multiple behavioral risk factor interventions in primary care. *Am J Prev Med* 2004;27(2 Suppl):61–79.
46. Berry C, Kennedy P, Hindson LM. Internal consistency and responsiveness of the Skin Management needs assessment checklist post-spinal cord injury. *J Spinal Cord Med* 2004;27:63–71.
47. Steele LL, Ferguson-Pell MW, Paeglow TN, Stevens FG, Davis K. Peer information network: an evaluation of peer counselling in the prevention of pressure sores among persons with spinal cord injury. Preliminary report. New York State Prevention Program Special Project. Personal communication.
48. Gibson L. Perceptions of pressure ulcers among young men with a spinal injury. *Br J Community Nurs* 2002;7:451–60.
49. Schubart JR, Hilgart M, Lyder C. Pressure ulcer prevention and management in spinal cord-injured adults: analysis of education needs. *Adv Skin Wound Care* 2008;21:322–9.

CONTENTS

BODY WEIGHT AND NUTRITION	51
PRINCIPLES	51
Role of nutrition in pressure ulcer risk and healing	51
Registered dietitian	51
Resources	51
Nutrition screening tools	52
NUTRITIONAL ASSESSMENT	52
Anthropomorphic measures: underweight, overweight, and obesity	52
Weight loss	53
Overweight and obesity	53
Dietary intake and losses	54
Calorie intake	54
Protein status	55
Hydration	55
Micronutrients	55
Nutrition- and hydration-related blood work	56
INTERVENTIONS	56
Nutritional management	56
Factors influencing nutritional status	56
Calories	56
Protein	57
Hydration	57
Amino acid supplementation	58
Micronutrients	58
<i>Vitamin A</i>	59
<i>Vitamin C</i>	59
<i>Vitamin E</i>	59
<i>Iron</i>	59
<i>Zinc</i>	59
Contraindications and precautions to supplementation	60
Enteral and total parenteral nutrition	60

HEMATOLOGIC AND BIOCHEMICAL PARAMETERS OF HEALING 61

 RECOMMENDED BLOOD WORK 61

 Evidence 61

 Anemia 62

 Inflammatory markers 62

 Endocrine factors 63

 Glucose metabolism 63

 Thyroid function 63

CONCLUSIONS 64

REFERENCES 64

Body weight and nutrition

PRINCIPLES

Role of nutrition in pressure ulcer risk and healing

Nutritional factors play an important role in pressure ulcer risk and healing, and the high prevalence of malnutrition in people at risk of, or with, pressure ulcers necessitates a structured approach to nutritional interventions in these individuals.



It is therefore appropriate to consider problems with nutrition and hydration as pressure ulcer risk factors and as contributing factors to pressure ulcer development in all people with spinal cord injury and pressure ulcers, until these factors have been investigated and either confirmed or ruled out.

3.1: Nutritional deficiency and dehydration

Consider nutritional deficiencies and dehydration as risk factors for pressure ulcer development in a person with spinal cord injury until these factors have been ruled out.

RECOMMENDATION LEVEL IV



Registered dietitian



3.2: Assessment by a registered dietitian

Ensure that a registered dietitian who is part of the interprofessional team caring for the person with spinal cord injury performs the nutrition assessment, determines and recommends the appropriate intervention, and assesses the outcome.

RECOMMENDATION LEVEL IV

Evaluation and treatment of nutrition deficits in people with spinal cord injury and pressure ulcers require advanced skills and an appreciation of the impact of spinal cord injury and the pathophysiology of wound healing. It is critical to consider the very complex interplay among a multitude of contributing factors before recommending dietary supplementation. For example, people with spinal cord injury and pressure ulcers may have concurrent medical conditions such as diabetes, hypothyroidism, or renal disease that may mask signs of underlying malnutrition or complicate supplementation programs. Nutritional assessment and management are more likely to meet the multifaceted individual needs of people with spinal cord injury and pressure ulcers when the intervention is customized. Given

RESOURCES

Data about nutrition and nutritional interventions to prevent or treat pressure ulcers in people with spinal cord injury are limited. For more detailed information on the importance of nutrition in pressure ulcer prevention and treatment, consult the following documents:

- Dorner B, Posthauer ME, Thomas D, National Pressure Ulcer Advisory Panel. *The role of nutrition in pressure ulcer prevention and treatment: National Pressure Advisory Panel White Paper.*⁽¹⁾
- Registered Nurses' Association of Ontario. *Nursing best practice guideline: Assessment & Management of Stage I to IV Pressure Ulcers 2011.*⁽²⁾

the complexity of this clinical situation, a trained and experienced registered dietitian must evaluate dietary intake, identify causative factors, and implement a program that will be both effective and accepted by the person.

Nutrition screening tools

No screening tool specific to people with spinal cord injury is available.

- The *Mini Nutritional Assessment (MNA)*[®], which was developed in a geriatric population, can assist clinicians in predicting the risk of malnutrition. Langkamp-Henken et al concluded the MNA was a simple tool to determine the nutritional status of geriatric patients with pressure ulcers.⁽³⁾ To date, no study has demonstrated the validity of the MNA in people with spinal cord injury.
- The *Braden Scale*, which assesses pressure ulcer risk, has a nutrition subscale,⁽⁴⁾ but this has not been validated in people with spinal cord injury.⁽⁵⁾
- The *Spinal Cord Injury Pressure Ulcer Scale (SCIPUS)* is another pressure ulcer risk assessment tool that may help to identify nutritional problems, as it includes laboratory tests. SCIPUS has not been validated as a screening tool for malnutrition.⁽⁶⁾

In the absence of a screening tool for nutritional deficiencies specific to the population with spinal cord injury, it is recommended that a skilled dietitian assess the dietary needs and nutritional status of each person with spinal cord injury who is at risk of developing, or who presents with, a pressure ulcer. A comprehensive assessment helps evaluate each person’s nutritional risk factors. Early intervention with optimal calories, protein, vitamins, minerals, and fluid helps to reduce the risk of pressure ulcer development. People with a pressure ulcer have a much greater risk of further skin breakdown and delayed ulcer healing if nutritional deficiencies are not addressed promptly and adequately.

NUTRITIONAL ASSESSMENT

3.3: Components of nutritional assessment

Assess nutritional status of all spinal cord–injured individuals who are at risk of developing a pressure ulcer, or present with a pressure ulcer on admission, with each change in condition and when the pressure ulcer is not healing at the expected rate. This assessment should include the following:

	RECOMMENDATION LEVEL
■ Anthropometric measurements	IV
■ Dietary intake and losses	IIb
■ Nutrition- and hydration-related blood work	III
■ Ability to self-feed or dependence on others for eating and drinking	IV
■ Other barriers to optimal food and fluid intake	IV

RECOMMENDATION LEVEL IIB-IV



Anthropomorphic measures: underweight, overweight, and obesity

3.4: Serial weight measurement

Perform serial body weight measurements at least every 30 days to identify recent weight loss as an indicator of nutritional deficiency and pressure ulcer risk.

RECOMMENDATION LEVEL IV



It is important to measure body weight and calculate body mass index (BMI) by dividing weight in kilograms by height in metres squared. Serial routine body weight measurements provide information about weight stability, recent unintentional weight loss, or weight gain. These trends, which can affect pressure ulcer risk, cannot be identified unless weight is measured regularly.

WEIGHT LOSS

More frequent body weight measurement helps identify weight loss more rapidly. Serial weight measurements are the most noninvasive, time-efficient, inexpensive and reliable indicator of nutritional stability. Recent weight loss may be the best indicator of nutritional deficiency and pressure ulcer risk. All weight loss, whether intentional or unintentional, is catabolism. Inappropriate or overzealous dietary restriction sufficient to produce weight loss may negatively affect pressure ulcer healing. Weight loss is generally recommended for obese individuals; however, pursuit of weight loss may need to be modified or postponed to ensure the provision of optimal nutrients for pressure ulcer healing.⁽¹⁾ A strong association exists between recent weight loss, pressure ulcer development, and poor healing. Individuals who have not lost weight may also be deficient in key nutrients needed for optimal wound healing, including protein and micronutrients.

OVERWEIGHT AND OBESITY

Some reports suggest obesity may be a risk factor for pressure ulcer development and poor healing; adipose tissue in the buttock region does not protect against the development of ischial pressure ulcers.



Neither overweight nor obesity implies over-nutrition.

The NPUAP white paper states “weight loss efforts may need to be modified or postponed temporarily to provide sufficient nutrients for pressure ulcer healing.”⁽¹⁾ Weight maintenance is recommended for the overweight or obese person with a pressure ulcer, along with the provision of lean protein sources, appropriate amounts of vitamins and minerals, and adequate fluid intake. *Research is needed to define the appropriate range of daily caloric intake for obese individuals with pressure ulcers.*⁽⁵⁾



The utility of BMI to screen for obesity in people with spinal cord injury has not yet been established.

Laughton et al found that this value failed to identify 73.9% of individuals with spinal cord injury who were determined obese using bioelectrical impedance analysis to measure body composition.⁽⁷⁾ The authors felt a BMI of 30 kg/m² significantly underestimated the magnitude and prevalence of obesity in adults with spinal cord injury and consequently recommended an upper BMI limit of 22 kg/m² to define obesity in people with spinal cord injury and obesity-related chronic disease.⁽⁷⁾ De Groot et al used this 22 kg/m² BMI value as a cut-off to perform a prospective analysis of the prevalence of obesity in people with spinal cord injury during and up to 5 years after discharge from inpatient rehabilitation.⁽⁸⁾ Use of a BMI cut-off value of 22 kg/m² to identify obesity categorized 75% of study participants as obese or overweight by 1 year after discharge from rehabilitation.

Laughton et al suggested that waist circumference may be a better indicator of the risk of obesity-related chronic diseases, as it correlates more closely with visceral adipose tissue deposition, which increases coronary heart disease risk.⁽⁷⁾ Other researchers have also confirmed a strong relationship between waist circumference and visceral adiposity.⁽⁹⁾ Edwards et al reported that participants with spinal cord injury had 42% more visceral adipose tissue per centimetre of waist circumference than able-bodied individuals. Interestingly, a cohort of males with spinal cord injury who considered themselves active and healthy had significantly greater mean visceral adipose tissue (58%, $p = .003$) than age-matched able-bodied controls.





Waist circumference is a surrogate marker for visceral adiposity in this population.

Dietary intake and losses

It is important to assess dietary intake of calories, protein, fluid, and micronutrients and the extent of losses to determine whether individual requirements are being met. Nutrient and fluid loss through the wound can be extensive, especially if multiple exudative wounds or fistulae are present or if negative pressure wound therapy is used. Nutrient losses can lead to or exacerbate malnutrition and hypoalbuminemia. The most common routes of nutrient and fluid loss are the gastrointestinal tract (i.e., emesis, malabsorption, and frequent loose stools), and the urinary tract. Urinary tract losses increase with the use of diuretics and with hyperglycemia. The aging kidney is less able to concentrate urine.

It is important to monitor regularly for signs and symptoms of dehydration, such as decreased urine output and concentrated urine, changes in skin turgor, tachycardia, thick secretions, and altered blood values.

Poor nutritional status and decreased nutritional intake are important risk factors for pressure ulcer development and interfere with pressure ulcer healing in people with spinal cord injury.^(10–12) Inadequate food intake and worsening appetite for 3 consecutive days have been considered clinically important predictors of pressure ulcer development.



Inadequate intake, poor nutritional status, excessive nutrient and fluid losses, and unintentional weight loss are associated with impaired healing.

Although nutritional status has an important impact on pressure ulcer prevention, no single factor consistently confirms adequacy of nutrition.⁽¹³⁾ It is important to consider problems with nutrition and hydration as contributing factors to pressure ulcer development in all people with spinal cord injury until these factors have been investigated and either confirmed or ruled out.

National Pressure Ulcer Advisory Panel/European Pressure Ulcer Advisory Panel (NPUAP/EPUAP) guidelines state that nutritional assessment should compare nutrient intake with estimated requirements,⁽¹⁾ but there is little consensus regarding the required amount of energy, nutrients, and fluid to support the physiological demands of a person with spinal cord injury with one or more pressure ulcers.

CALORIE INTAKE

Aquilani et al performed a study in 10 people with paraplegia, significant asymptomatic bacteriuria, and pressure ulcers to determine resting energy expenditure, the impact of bacteriuria and pressure ulcers on metabolic rate, and the adequacy of nutritional intake to preserve protein levels.⁽¹²⁾ Controls were five sedentary subjects without spinal cord injury who had recently lost weight as a result of dieting. Resting energy expenditure was calculated from indirect calorimetry measurements. Over 2 months, the individuals with paraplegia lost a mean 10 kg of body weight, similar to the controls. Resting energy expenditure in people with paraplegia was significantly greater than in the controls ($p < .001$). More than half of the test subjects had a calorie and protein intake inadequate to meet their metabolic demands. The authors concluded that the minimum adequate caloric intake for individuals with spinal cord injury, pressure ulcers, and asymptomatic bacteriuria that was required to preserve their nutritional status may be 28.5 kcal/kg/day.

Cereda et al conducted a systematic review and meta-analysis of five studies of energy balance in people with pressure ulcers; three studies included people with spinal cord injury. The authors concluded that pressure ulcers increase resting energy expenditure, whereas study participants had reduced energy intake and were, therefore, in negative energy

balance. Results of the meta-analysis supported a recommendation of a minimum 30 kcal/kg/day energy intake and emphasized the role of medical nutrition therapy in wound healing.⁽¹³⁾

PROTEIN STATUS

Albumin and prealbumin are hepatic proteins that are often used as markers of protein and nutrition status.⁽¹⁴⁾ This is controversial, however, and many clinicians and authors dispute the value of albumin and prealbumin as nutritional markers, especially in critical care and acute care settings. Multiple factors such as infection, acute stress, and surgery contribute to low albumin and prealbumin levels, even in the presence of adequate protein and nutrient intake. As a result, the value of these biomarkers as indicators of malnutrition may be limited.



Low albumin and prealbumin values reflect the severity of illness or injury and the potential for the development or worsening of malnutrition, regardless of nutrition status. Immediate and appropriate nutrition interventions are indicated.

HYDRATION

3.5: Monitor hydration

Assess people with spinal cord injury for clinical signs and symptoms of dehydration.

RECOMMENDATION LEVEL IV



Inadequate fluid intake may result in dehydration, which is a risk factor for skin breakdown and delayed wound healing.⁽¹⁵⁾

Blood urea nitrogen (BUN) and creatinine provide information on both hydration and renal function. Elevated BUN accompanying a low or normal creatinine level may suggest dehydration, and the higher the BUN/creatinine ratio, the more significant the dehydration.



A BUN/creatinine ratio greater than 20:1 is a red flag for dehydration that must be investigated and addressed. This ratio may not be an accurate indicator of hydration in people with renal impairment.

Whether or not laboratory assessment is readily available, it is essential that a person with spinal cord injury be assessed clinically for signs and symptoms of dehydration.

MICRONUTRIENTS

The cost of obtaining blood levels of certain micronutrients may be a barrier to assessment of these levels in some situations. In addition, valid and definitive tests do not yet exist for some micronutrients. Furthermore, it may not always be practical to obtain micronutrient blood levels, as the tests may not be readily available in all areas; waiting for test results may only delay nutritional intervention. Obtaining micronutrient levels is just one part of a comprehensive nutritional assessment.



Nutrition- and hydration-related blood work

Laboratory assessment of nutrition should include serum albumin and/or prealbumin, BUN, creatinine, BUN/creatinine ratio, and electrolytes.⁽¹⁶⁾ Although laboratory investigation assists in evaluating the nutritional status of patients at risk for pressure ulcer development or delayed healing, “no single laboratory test can specifically determine an individual’s nutritional status.”⁽¹⁾ Several factors affect nutrition- and hydration-related blood values; it is therefore imperative that laboratory results are not interpreted in isolation of other values or data obtained from other components of a comprehensive nutrition assessment, such as adequacy of nutrient intake, changes in weight status, concurrent medical conditions, medications, physical activity, and other factors.



Recommended Blood Work (PAGE 61) provides details of the tests recommended.

INTERVENTIONS

Nutritional management

3.6: Nutritional intake and support

Implement early nutritional support measures if dietary intake is inadequate or if an individual is nutritionally compromised.

RECOMMENDATION LEVEL IV

A nutritionally complete and balanced diet is integral to prevention and treatment of pressure ulcers.^(17,18) The literature on nutritional interventions to prevent or treat pressure ulcers in people with spinal cord injury is limited. More research has examined the role of nutrition on pressure ulcer risk and healing in a general population of elderly individuals. Regular monitoring of nutritional status is necessary to identify appropriate nutritional interventions to prevent and treat pressure ulcers. A can of supplement does not replace comprehensive nutrition assessment or individualized intervention.⁽¹⁶⁾

Factors influencing nutritional status

A comprehensive nutrition plan includes several important practical considerations that enhance the acceptance, and therefore effectiveness, of the intervention. To develop the nutritional plan it is critical to know the following:

- The person’s ability to self-feed or the amount and type of assistance needed for eating and drinking; people at greatest risk of malnutrition and dehydration are those who are dependent on others for food and fluid
- All barriers to food and fluid consumption, including dentition, food allergies, food preferences, cultural and religious issues, dysphagia, cognition, vision, communication, financial resources, and psychosocial issues
- Food preferences in terms of the type, timing, or combinations of foods to ensure the implementation program is acceptable and successful

CALORIES

3.7: Daily caloric intake

Provide 30 to 35 kcal/kg energy daily for people with pressure ulcers

RECOMMENDATION LEVEL III



Pressure ulcers increase the energy needs of individuals with spinal cord injury, with larger pressure ulcer area linked to greater energy requirements. An increased caloric intake is associated with improved healing of pressure ulcers in the general population.^(1,17)

Guidelines developed for the general population with pressure ulcers suggest 30 to 35 kcal/kg/day as an appropriate caloric intake; some authors recommend a higher caloric intake.^(1,2,11) Predictive equations may be useful in estimating energy requirements, but because individual differences complicate energy calculations, equations may be inaccurate. Indirect calorimetry, the best method to determine energy requirements, is not always available. It is important to monitor weight closely and adjust the amount of energy provided based on weight change or stability and treatment goals.

PROTEIN

3.8: Daily protein intake

Provide 1.0 to 2.0 g/kg protein daily for people at risk of developing pressure ulcers.

Provide a daily protein intake at the higher end of the range for people with severe pressure ulcers.

RECOMMENDATION LEVEL IA

Research has found pressure ulcer healing is significantly greater in people receiving high-protein supplements. Van Anholt et al performed a randomized, controlled, double-blind, parallel group trial to investigate the potential of a high-protein oral nutritional supplement to influence healing of stage III or IV pressure ulcers in 43 elderly non-malnourished individuals, a population that would not normally receive nutritional support.⁽¹⁷⁾ The treatment group, which received an oral supplement in addition to the normal diet, had significantly reduced ulcer size ($p \leq 0.016$) and severity ($p \leq 0.033$) compared with the control group, which received a normal diet. The authors concluded that oral supplementation can accelerate pressure ulcer healing and decrease wound care intensity in non-malnourished patients.

A systematic review and meta-analysis of the clinical impact of nutritional support in patients with, or at risk of developing, pressure ulcers included eight randomized controlled trials of oral nutritional supplements or enteral tube feeding.⁽¹⁸⁾ High-protein oral supplementation reduced the risk of pressure ulcer development by 25%. These data provide strong support for protein supplementation, although the studies included in the meta-analysis were not performed in people with spinal cord injury.

It is important to ensure a positive nitrogen balance in a person with a pressure ulcer. Although the exact amounts of protein needed to meet nutritional requirements of people with spinal cord injury who have pressure ulcers is unknown, recommended values range between 1.0 and 2.0 g/kg, with most recommendations between 1.25 and 1.5 g/kg.⁽⁵⁾ A daily protein intake of up to 2.0 g/kg has been recommended for people with more severe pressure ulcers, but it is important to note that this high level of protein intake has been associated with dehydration in older adults.⁽⁵⁾



As impaired renal function is the predominant precaution or contraindication to increasing dietary protein, it is essential to ensure renal function is normal before initiating supplementation.

HYDRATION

3.9: Provide adequate fluids

Estimate fluid requirements, based on 1 mL/kcal food consumed, and provide adequate fluids to maintain hydration.

RECOMMENDATION LEVEL IV



A general formula to estimate fluid requirements for the maintenance of hydration is 1 mL fluid for each kcal of food consumed.⁽²⁰⁾ Factors increasing fluid loss, and therefore fluid requirements, above expected levels are sweating, vomiting, diarrhea, diuresis due to diuretics or hyperglycemia, and losses through fistulae and highly exudative wounds. Increasing protein intake may also increase fluid requirements.

AMINO ACID SUPPLEMENTATION

3.10: Arginine supplementation

Consider supplementing arginine to promote more rapid pressure ulcer healing if no contraindications exist.

RECOMMENDATION LEVEL III

Arginine and glutamine are amino acids often associated with pressure ulcer healing. Arginine is involved in nitric oxide synthesis, and it stimulates insulin secretion.⁽²¹⁾

Brewer et al conducted an observational study of the effect of arginine supplementation on healing time of pressure ulcers in 18 people with spinal cord injury.⁽²²⁾ Healing times were compared with a historical control group of 17 individuals. The participants received a powdered arginine supplement, 9 g/day, until full healing occurred. Mean healing time in the experimental group was 10.5 ± 1.3 weeks, approximately half the time needed for healing in the control group, 21 ± 3.7 weeks ($p < .05$). These beneficial results are consistent with a study that found faster healing of pressure ulcers when an arginine-rich supplement was provided to a general population with pressure ulcers.⁽²³⁾ Although these studies demonstrate a potential benefit of arginine supplementation on pressure ulcer healing, it should be noted that the supplement contained other nutrients in addition to arginine, and therefore improved healing outcomes cannot be attributed to arginine specifically. *A controlled study is needed to examine the effects of arginine supplementation, without the addition of other nutrients, on pressure ulcer healing rates.*

Glutamine supplementation has been suggested to support pressure ulcer healing, but no research yet demonstrates its ability to reduce pressure ulcer risk or speed closure of existing pressure ulcers.

MICRONUTRIENTS

3.11: Vitamin and mineral supplementation

Consider supplementing vitamins and minerals in people with known deficiencies to improve pressure ulcer healing. Use clinical judgment and the results of a thorough nutritional assessment to determine the need for nutrient supplementation in the absence of definitive tests for deficiencies.

RECOMMENDATION LEVEL IV

Micronutrient deficiencies have been associated with delayed wound healing but not with the risk of pressure ulcer development.⁽¹³⁾ Vitamin and mineral supplementation in people without deficiencies has not been shown to enhance healing of pressure ulcers. No universally accepted method, however, accurately measures the status of some micronutrients, such as zinc, and therefore some micronutrient deficiencies may go undetected.⁽²⁴⁾ As a result, the best guide to the need for micronutrient supplementation may be clinical judgment, based on a comprehensive nutrition assessment.⁽²⁵⁾

Micronutrients considered important for wound healing include vitamin C and zinc.⁽¹⁾ These nutrients are available from many food sources and can therefore be obtained from a balanced diet. People with pressure ulcers or acute illness, however, may be more likely to present with barriers to optimal intake; they may have greater nutrient losses or impaired nutrient utilization because of physiological stress and may require specific vitamin and mineral supplementation.



VITAMIN A

Vitamin A is necessary for epithelialization and collagen synthesis, and it improves cell-mediated immunity. It has been suggested that this vitamin plays a unique role in counteracting the delay in wound healing caused by steroids, diabetes, and radiation damage.⁽²⁶⁾

Moussavi et al performed a study assessing serum vitamin levels in 110 adults with spinal cord injury of at least 2 years' duration who were living in the community.⁽²⁷⁾ Many participants had vitamin deficiencies. Higher levels of vitamin A were associated with the absence of a pressure ulcer during the previous 12 months.

VITAMIN C

Vitamin C has several roles in wound healing, including involvement in collagen synthesis and optimal immune function. Impaired ability to fight infection has been documented in people with vitamin C deficiency. Although megadoses of vitamin C have not been shown to accelerate wound healing and may even have detrimental effects,⁽²⁸⁾ it has been recommended that giving vitamin C at physiological doses be considered when dietary deficiency is suspected.⁽¹⁾

VITAMIN E

3.12: Vitamin E supplementation

Avoid vitamin E supplementation, as it may delay healing of pressure ulcers.

RECOMMENDATION LEVEL IV

Several authors have suggested that excess vitamin E can interfere with wound healing and fibrosis and that tocopherols can antagonize the promotion of wound healing by vitamin A.^(29,30) Ehrlich et al demonstrated in an animal model that vitamin E supplementation inhibited collagen synthesis.⁽²⁹⁾ Albina stated, "The clinical relevance of this function of vitamin E in modulating wound healing remains to be established."⁽³¹⁾ The Academy of Nutrition and Dietetics Evidence Analysis Library states: "The effect of vitamin E in healing acute and chronic wounds is controversial. Use caution when supplementing with vitamin E as there is evidence from animal studies that vitamin E may delay healing by impairing collagen synthesis."⁽³¹⁾ *Human randomized controlled trials are needed to determine the risks and benefits of various doses of vitamin E and the effect on healing.*

IRON

Iron is incorporated into hemoglobin and plays a critical role in oxygen transport, making it an essential micronutrient for optimal tissue perfusion. Iron is also necessary for collagen synthesis. Anemia can cause tissue ischemia, impair collagen cross-linking, and decrease wound strength.⁽³¹⁾ If iron-deficiency anemia is identified, iron supplementation and enhanced dietary iron are recommended. It is critical, however, to investigate the cause of the anemia and to differentiate iron-deficiency anemia from anemia of chronic disease, as inappropriate iron supplementation for anemia of chronic disease, in the absence of iron-deficiency anemia, can cause iron overload.^(31, 32)

ZINC

Zinc is needed for protein synthesis, enzyme activation, and cell duplication. Zinc deficiency may be associated with poor appetite, abnormal taste acuity, impaired immune function, and delayed wound healing.^(1,33) Clinical trials have not directly demonstrated the effects of zinc supplementation on wound healing, but zinc supplementation may be beneficial when dietary intake is poor or deficiencies are confirmed or suspected.⁽¹⁾ No universally accepted methods accurately assess zinc status.^(24,25) Clinical judgment is therefore the best guide to the decision to implement zinc supplementation.⁽³³⁾ Recommended dose and duration of supplementation vary.^(1,33,34) Potential adverse effects of inappropriate chronic zinc supplementation include gastrointestinal distress, immunosuppression, impairments in lipid profile, and secondary copper deficiency, but acute zinc toxicity is rare.^(24,35)



Contraindications and precautions to supplementation

3.13: Contraindications and precautions to supplementation

Identify all conditions that may be precautions or contraindications to supplementation, such as renal insufficiency, before implementing micronutrient, protein, or fluid supplementation.

RECOMMENDATION LEVEL IV

Contraindications and precautions to supplementation may exist in specific clinical situations, such as renal insufficiency, and in certain individuals. Other precautions or contraindications secondary to concurrent health issues must be considered before enhancing nutrients or fluids and before implementing supplementation.

- Watch for impaired renal function when supplementing protein.⁽³⁶⁾ Consider increasing fluid provision when dietary protein is enhanced.⁽¹⁾
- Impaired renal function, congestive heart failure, and syndrome of inappropriate antidiuretic hormone (SIADH) should be ruled out before increasing fluid intake.^(36–38)
- People are at greater risk of renal stone development with vitamin C supplementation.^(1,39)
- Vitamin A supplementation should be avoided in the presence of chronic renal failure.⁽⁴⁰⁾
- Since iron supplementation in anemia of chronic disease can result in hemochromatosis,⁽⁴¹⁾ it is necessary to determine that an iron deficiency exists before supplementing with iron.⁽⁴²⁾
- The most common side effect of zinc supplementation is gastrointestinal distress. Inappropriate supplementation may be associated with alterations in immune response or lipid profile and secondary copper deficiency.⁽⁴³⁾

The considerations above are not exhaustive lists of the precautions or contraindications to nutrient or fluid supplementation; they include some common clinical conditions that must be identified and considered before enhancing or modifying nutrients or fluid to promote wound healing.

Before considering supplementation for persons who receive tube feeding, assess the nutrient and fluid provision from the tube feeding formula and current water flushes. The tube feeding and flushes may already meet or exceed the person's requirements.)

Enteral and total parenteral nutrition

3.14: Enteral and total parenteral nutrition

Provide enteral nutrition to support pressure ulcer healing, if indicated, when the gastrointestinal tract is intact but dietary intake is inadequate and/or barriers to oral intake exist.

Provide total parenteral nutrition, if indicated, to people with pressure ulcer and gastrointestinal dysfunction or disease.

RECOMMENDATION LEVEL IV



Numerous strategies may be necessary to manage an individual's nutrition status effectively, including enhancing meals and snacks with additional foods, incorporating liquid or powder supplements, initiating appropriate vitamin and mineral supplementation, and providing enteral or parenteral nutrition support.

People with inadequate intake and/or barriers to oral intake may receive enteral nutrition (tube feeding) directly into the gastrointestinal tract, if they have a functional gastrointestinal tract. Nasogastric, nasoduodenal, or nasojejunal routes may be selected for short-term enteral feeding, while gastrostomy, gastrojejunostomy, or jejunostomy tubes may be selected

for long-term use. The composition of the enteral formula is individually determined and must consider any concurrent disease processes. Total parenteral nutrition may be required for individuals with gastrointestinal disease. Both enteral and parenteral nutrition may be valuable strategies to address nutritional deficiencies when less invasive strategies have been ineffective.⁽⁵⁾

Hematologic and biochemical parameters of healing

As comorbid conditions are common in people with spinal cord injury, it is appropriate to screen for markers of underlying disease that may be barriers to wound healing.

RECOMMENDED BLOOD WORK

3.15: Recommended blood work to help identify underlying barriers to healing

Screen for common conditions, such as anemia, inflammation, diabetes, and hypothyroidism, which are known to delay healing, to ensure appropriate treatment. Perform the following tests:

- *Complete blood count*, including hemoglobin, hematocrit, white blood cell count, absolute lymphocyte count, and description of red blood cell morphology
- *Iron profile*, including ferritin, serum iron, percentage saturation, and total iron binding capacity
- *Inflammatory markers*: C-reactive protein and erythrocyte sedimentation rate
- *Endocrine factors*, including fasting or random blood glucose, hemoglobin A1C and thyroid function tests

RECOMMENDATION LEVEL III



The following blood tests are recommended:

- *Complete blood count*: Hemoglobin and hematocrit can identify anemia; total white blood cell count can suggest systemic infection; and absolute lymphocyte count can indicate nutrition status.⁽⁴³⁾
- *Iron status*: Analysis of serum iron, total iron binding capacity, percent saturation, and ferritin can distinguish between iron-deficiency anemia and anemia of chronic disease.
- *Inflammatory markers*: Pressure ulcers are a chronic inflammatory condition, and C-reactive protein (CRP) and erythrocyte sedimentation rate (ESR) are increased in people with pressure ulcers. Concurrent assessment of these markers can assist in distinguishing iron-deficiency anemia from anemia of chronic disease.
- *Endocrine factors*: Fasting or random blood glucose and hemoglobin A1C (HbA1C) can identify the presence of prediabetes or diabetes, and thyroid function tests can detect thyroid abnormalities, such as hypothyroidism. Management of endocrine factors affecting metabolism, such as diabetes or hypothyroidism, is essential to restore skin integrity.

Evidence

Several hematologic and biochemical parameters reflect nutrition status and the risk of malnutrition or are correlated with factors associated with pressure ulcer risk or impaired healing. Subgroup analysis of a multicentre, prospective, controlled clinical trial that followed participants with recurrent and chronic pressure ulcers for at least 6 months found less healing when two or more abnormal blood values were identified before treatment.⁽⁴⁴⁾

Anemia

Low hemoglobin levels can be seen in people with spinal cord injury.⁽⁴⁵⁾ Decreased hemoglobin levels are linked to an increased incidence of pressure ulcers, and reduced tissue oxygenation associated with anemia impairs pressure ulcer healing.⁽⁴⁶⁾

Iron-deficiency anemia and anemia of chronic disease are prevalent forms of anemia that share common characteristics, making them difficult to distinguish.⁽⁴⁷⁾ A full iron profile is important to help differentiate them.⁽⁴⁸⁾ Iron-deficiency anemia may result from blood loss or nutritional deficiency due to malabsorption or chronic inadequate intake.⁽³⁹⁾ Hemoglobin, hematocrit, and reticulocyte count are decreased in both types of anemia (Table 1). Features of iron-deficiency anemia are hypochromic, microcytic red blood cells, decreased serum iron, and low ferritin levels. Anemia of chronic disease is associated with normochromic, normocytic red blood cells, decreased serum iron, and normal or increased ferritin levels.

Standard measures of iron status do not always distinguish between iron-deficiency anemia and anemia of chronic disease, because these measures are directly affected by chronic disease, inflammation, and infection, and because both types of anemia can coexist.^(36,48) In the absence of infection, inflammation, or malignancy, ferritin will be low in iron-deficiency anemia. Infection, inflammation, and malignancy are associated with anemia of chronic disease. A pressure ulcer is an inflammatory condition. Ferritin is a positive acute-phase reactant that is elevated in anemia of chronic disease. It is recommended that the markers of inflammation, CRP and ESR, also positive acute-phase reactants, be assessed concurrently to assist in distinguishing between iron-deficiency anemia and anemia of chronic disease.

Table 1. Differentiation of Iron-Deficiency Anemia and Anemia of Chronic Disease

PARAMETER	IRON-DEFICIENCY ANEMIA	ANEMIA OF CHRONIC DISEASE
Hemoglobin	↓	↓
Hematocrit	↓	↓
Reticulocyte count	↓	↓
Red blood cells	Hypochromic microcytic	Normochromic normocytic
Serum iron	↓	↓
Ferritin	↓	Normal or ↑
Total iron binding capacity	↑	Normal or ↓
% saturation	↓	Normal or ↓
C-reactive protein	Normal	↑
Erythrocyte sedimentation rate	Normal	↑

Inflammatory markers

Davies et al used a cross-sectional study design to evaluate proinflammatory cytokine levels in 56 people with spinal cord injury and 35 age-matched able-bodied controls and the relation between increased cytokine levels and clinical factors.⁽⁴⁹⁾ Cytokine levels were significantly higher ($p < .05$) in people with spinal cord injury than in controls, although they were asymptomatic for any medical condition. Even greater elevations were seen in individuals with spinal cord injury and neuropathic pain, urinary tract infection, or pressure ulcers.

Scivoletto et al evaluated anemia, total protein, and inflammatory markers in 13 people with spinal cord injury and pressure ulcers, 13 people with spinal cord injury without pressure ulcers, and four individuals with other diseases and pressure ulcers.⁽⁵⁰⁾



Individuals with pressure ulcers had anemia of chronic disease, hypoproteinemia, hypoalbuminemia, and increased ESR and CRP. After surgical intervention to heal the pressure ulcers, the values quickly returned to normal.

A cross-sectional study to evaluate blood and serum markers associated with pressure ulcers in people with spinal cord injury included 23 people with pressure ulcers and 25 without pressure ulcers.⁽⁴⁷⁾ In comparison with individuals without pressure ulcers, the group with pressure ulcers had anemia, increased CRP, ESR, and white blood cells, but decreased lymphocytes, total protein, albumin, and zinc.



Pressure ulcer grade was significantly correlated with increased white blood cell counts and CRP and with decreased lymphocyte counts, hemoglobin, hematocrit, red blood cell counts, and serum protein.

Endocrine factors

GLUCOSE METABOLISM

People with spinal cord injury have an increased risk of type 2 diabetes.⁽⁵¹⁻⁵³⁾ Diabetes significantly impairs wound healing and increases complication rates.⁽⁵⁴⁻⁵⁶⁾ Detection and management of hyperglycemia are critical to ensure an optimal wound healing environment.⁽⁵⁷⁾



The importance of controlling blood glucose levels to promote wound healing cannot be overemphasized.⁽⁵⁶⁾ Hyperglycemia in people with spinal cord injury results largely from insulin resistance and impaired glucose tolerance. Although fasting blood glucose may be normal, impaired glucose tolerance after a meal or carbohydrate load can be present.^(58,59)

As a result, fasting blood glucose testing alone may not identify prediabetes or diabetes in people with spinal cord injury. Oral glucose tolerance testing may be needed to identify impaired glucose tolerance. Glycated hemoglobin (HbA1C) is a valuable measure that reflects glycemic control over the previous 2 to 3 months. HbA1C values above 7% are associated with a significantly increased risk of both macrovascular and microvascular complications.⁽⁵⁸⁾ Factors that can affect (increase or decrease) HbA1C include erythropoiesis, glycation, erythrocyte destruction, assays, and altered hemoglobin including iron deficiency and vitamin B12 deficiency.^(59,60)



It is recommended that both fasting blood glucose and HbA1C be measured in people with spinal cord injury and pressure ulcers to identify impaired glucose tolerance or hyperglycemia.

THYROID FUNCTION

Hypothyroidism is a metabolic disorder that affects maintenance of tissue integrity and regeneration and adversely affects wound healing. Hypothyroidism has been found concomitantly with diabetes mellitus.⁽⁶¹⁾ The influence of these conditions individually and together warrants screening for and immediate management of these conditions for optimal wound healing.

CONCLUSIONS

Comprehensive nutrition assessment of an individual with spinal cord injury who presents with or is at risk of developing a pressure ulcer is imperative. It is important to consider nutritional inadequacies and dehydration as risk factors for pressure ulcer development or as barriers to healing in all people with spinal cord injury until they have been investigated and either confirmed or ruled out. Nutritional assessment includes many factors, such as adequacy of intake from all sources compared with estimated needs; losses of nutrients and fluid; endocrine, hematologic, and biochemical factors; body weight status; dependence on others for eating and drinking; and other practical considerations. It is important to base the nutrition intervention on objective data where they are available. In the absence of objective data, sound clinical judgment and expert opinion must consider all relevant factors.

REFERENCES

1. Dorner B, Posthauer ME, Thomas D, National Pressure Ulcer Advisory Panel. The role of nutrition in pressure ulcer prevention and treatment: National Pressure Advisory Panel White Paper. Available at <http://www.npuap.org/wp-content/uploads/2012/03/Nutrition-White-Paper-Website-Version.pdf>. Accessed September 20, 2012.
2. Registered Nurses' Association of Ontario. Nursing best practice guideline: Assessment & Management of Stage I to IV Pressure Ulcers 2011. Available at <http://www.rnao.org/bestpractices>. Accessed September 20, 2012.
3. Langkamp-Henken B, Hudgens J, Stechmiller JK, Herrlinger-Garcia KA. Mini Nutritional Assessment and Screening Scores are Associated with nutritional indicators in Elderly people with pressure ulcers. *J Am Diet Assoc* 2005;105:1590–6.
4. Bergstrom N, Braden BJ, Laguzza A, Holman V. The Braden Scale for predicting pressure sore risk. *Nurs Res* 1987;36:205–10.
5. Mortenson WB, Miller, WC and the SCIRE Research Team. A review of scales for assessing the risk of developing a pressure ulcer in individuals with SCI. *Spinal Cord* 2008;46:168–75.
6. Salzberg CA, Byrne DW, Cayten CG, van Niewerburgh P, Murphy JG, Viehbeck M. A new pressure ulcer risk assessment scale for individuals with spinal cord injury. *Am J Phys Med Rehabil* 1996;75:96–104.
7. Laughton GE, Buchholz AC, Martin Ginis KA, Goy RE, SHAPE SCI Research Group. Lowering body mass index cutoffs better identifies obese persons with spinal cord injury. *Spinal Cord* 2009;47:757–62. Epub 2009 Apr 7.
8. De Groot S, Post MWM, Postma K, Sluis TA, van der Woude LHV. Prospective analysis of body mass index during and up to 5 years after discharge from inpatient spinal cord injury rehabilitation. *J Rehabil Med* 2010;42:922–8.
9. Edwards LA, Bugaresti JM, Buchholz AC. Visceral adipose tissue and the ratio of visceral to subcutaneous adipose tissue are greater in adults with than in those without spinal cord injury, despite matching waist circumferences. *Am J Clin Nutr* 2008;87:600–7.
10. Berglund B, Nordström G. The use of the modified Norton Scale in nursing-home patients. *Scand J Caring Sci* 1995;9:165–9.
11. Consortium for Spinal Cord Medicine Clinical Practice Guidelines. Pressure ulcer prevention and treatment following spinal cord injury: a clinical practice guideline for health-care professionals. *J Spinal Cord Med* 2001;24(Suppl 1):S40–101.
12. Aquilani R, Boschi F, Contardi A, Pistarini C, Achilli MP, Fizzotti G, et al. Energy expenditure and nutritional adequacy of rehabilitation paraplegics with asymptomatic bacteriuria and pressure sores. *Spinal Cord* 2001;39:437–41.
13. Cereda E, Klersy C, Rondanelli M, Caccialanza R. Energy balance in patients with pressure ulcers: a systematic review and meta-analysis of observational studies. *J Am Diet Assoc* 2011;111:1868–76.
14. Fuhrman MP, Charney P, Mueller CM. Hepatic proteins and nutrition assessment. *J Am Diet Assoc* 2004;104:1258–64.
15. Zwiefelbofer D. Pressure ulcers: hydration. *Dietary Manager* 2007 Oct;18–21.
16. Fraser C. The identification of barriers to pressure ulcer healing using nutrition/hydration related blood work. *Wound Care Canada* 2010;8:20–5.
17. Van Anholt RD, Sobotka L, Meijer EP, Heyman H, Groen HW, Topinková E, et al. Specific nutritional support accelerates pressure ulcer healing and reduces wound care intensity in non-malnourished patients. *Nutrition* 2010;26:867–72. Epub 2010 Jul 3.
18. Stratton RJ, Ek AC, Engfer M, Moore Z, Rigby P, Wolfe R, Elia M. Enteral nutritional support in prevention and treatment of pressure ulcers: a systematic review and meta-analysis. *Ageing Res Rev* 2005;4⁽³⁾:422–50.

19. Yarkony GM. Pressure ulcers: a review. *Arch Phys Med Rehabil* 1994;75:908–17.
20. Clark M, Schols J, Benati G, Jackson P, Engfer M, Langer G, et al. Pressure ulcers and nutrition: a new European guideline. *J Wound Care* 2004;13:267–72.
21. Ennis WJ, Lee C, Meneses P. A biochemical approach to wound healing through the use of modalities. *Clin Dermatol* 2007;25:63–72.
22. Brewer S, Desneves K, Pearce L, Mills K, Dunn L, Brown D, et al. Effect of an arginine-containing nutritional supplement on pressure ulcer healing in community spinal patients. *J Wound Care* 2010;19:311–6.
23. Desneves KJ, Todorovic BE, Cassar A, Crowe TC. Treatment with supplementary arginine, vitamin C, and zinc in patients with pressure ulcers: a randomized controlled trial. *Clin Nutr* 2005;24:979–87.
24. Jamshed N, Schneider EL. Is the use of supplemental vitamin C and zinc for the prevention and treatment of pressure ulcers evidence-based? *Ann Long Term Care* 2010;18:28–32.
25. Wood RJ. Assessment of marginal zinc status in humans. *J Nutr* 2000;130 (5S Suppl):1350S–4S.
26. Williams JZ, Barbul A. Nutrition and wound healing. *Surg Clin North Am* 2003;83:571–96.
27. Moussavi RM, Garza HM, Eistles SG, Rodriguez G, Rintala DH. Serum levels of vitamins A, C, and E in persons with chronic spinal cord injury living in the community. *Arch Phys Med Rehabil* 2003;84:1061–7.
28. Vilter RW. Nutritional aspects of ascorbic acid: uses and abuses. *West J Med* 1980;133:485–92.
29. Ehrlich HP, Tarver H, Hunt TK. Inhibitory effects of vitamin E on collagen synthesis and wound repair. *Ann Surg* 1972;175:235–40.
30. Albina JE. Nutrition and wound healing. *J Parenter Enteral Nutr* 1994;18:367–76.
31. The Academy of Nutrition and Dietetics Evidence Analysis Library. Spinal Cord Injury (SCI) Assessment of Nutritional Needs for Pressure Ulcers. Micronutrient needs for persons with SCI with pressure ulcers. Vitamin E. ADA Evidence Analysis Library. Recommendations Summary. Available at http://www.adaevidencelibrary.com/template.cfm?template=guide_summary&key=2378&auth=1. Accessed September 16, 2011.
32. Clark SF. Iron deficiency anemia. *Nutr Clin Pract* 2008;23:128–41.
33. Fraser CH. Zinc supplementation for pressure ulcer management. *Wound Care Canada* 2011;9(4):7–10.
34. Stechmiller JK. Understanding the role of nutrition and wound healing. *Nutr Clin Pract* 2010;25:61–8.
35. Fosmire GJ. Zinc toxicity. *Am J Clin Nutr* 1990;51:225–7.
36. National Kidney Foundation. K/DOQI clinical practice guidelines for nutrition in chronic renal failure. *Am J Kidney Dis* 2000;35:S1–140.
37. Doley J. Nutrition management of pressure ulcers. *Nutr Clin Pract* 2010;25:50–60.
38. Palmer BF. Hyponatremia in patients with central nervous system disease: SIADH versus CSW. *Trends Endocrin Metab* 2003;14:182–7.
39. Sherman AR, Barkley M. Nutrition and wound healing. *J Wound Care* 2011; 20:357–67.
40. McClure SC, Chauncey K, Nipp RD. Vitamin A use today and its potential toxicities. *Clin Geriatr* 2010;18:41–5.
41. Spivak JL. Iron and anemia of chronic disease. *Oncology* 2002;16(9 Suppl 10):25–33.
42. Woloschuk DMM. A practical guide to anemias. *Pharm Practice* 1997;August:1–8.
43. Dickhaut SC, DeLee JC, Page CP. Nutritional status: importance in predicting wound-healing after amputation. *J Bone Joint Surg* 1984;66-A:71–5.
44. Houghton PE, Fraser CH. Biomarkers of wound healing. 3rd National Spinal Cord Injury Conference. Toronto, ON, November 6–8, 2008.
45. Fuoco U, Scivoletto G, Pace A, Vona VU, Castellano V. Anemia and serum protein alteration in patients with decubitus ulcer. *Spinal Cord* 1997;35:58–60.
46. Keast DH, Fraser C. Treatment of chronic skin ulcers in Individuals with anemia of chronic disease using recombinant human erythropoietin (EPO): a review of four cases. *Ostomy Wound Manage* 2004;50:64–70.
47. Gurcay E, Bal A, Gurcay AG, Cakei A. Evaluation of blood and serum markers in spinal cord injured patients with pressure sores. *Saudi Med J* 2009;30:413–7.
48. Jain S, Narayan S, Chandra J, Sharma S, Jain S, Malhan P. Evaluation of serum transferrin receptor and sTfR ferritin indices in diagnosing and differentiating iron deficiency anemia from anemia of chronic disease. *Indian J Pediatr* 2010;77:179–83. Epub 2010 Jan 20.

49. Davies AL, Hayes KC, Dekaban GA. Clinical correlates of elevated serum concentrations of cytokines and autoantibodies in patients with spinal cord injury. *Arch Phys Med Rehabil* 2007;88:1384–93.
50. Scivoletto G, Fuoco U, Morganti B, Cosentino E, Molinari M. Pressure sores and blood and serum dysmetabolism in spinal cord injury patients. *Spinal Cord* 2004;42:473–6.
51. Bauman WA, Spungen AM. Carbohydrate and lipid metabolism in chronic spinal cord injury. *J Spinal Cord Med* 2001;24:266–77.
52. Duckworth WC, Solomon SS, Jallepalli P, Hechemeyer C, Finnern J, Powers A. Glucose intolerance due to insulin resistance in patients with spinal cord injuries. *Diabetes* 1980;29:906–10.
53. Fraser C. Nutrition and wound care: the importance of investigating the presence of hyperglycemia in individuals with wounds. *Wound Care Canada* 2007;5:20–1.
54. Collins N. Diabetes, nutrition and wound healing. *Adv Skin Wound Care* 2003;16:291–4.
55. Lioupis MD. Effects of diabetes mellitus on wound healing: an update. *J Wound Care* 2005;14:84–6.
56. Arnold M, Barbul A. Nutrition and wound healing. *Plast Reconstr Surg* 2006;117(Suppl):42S–58S.
57. Marston WA. Risk factors associated with healing chronic diabetic foot ulcers: the importance of hyperglycemia. *Ostomy Wound Manage* 2006;52:26–39.
58. Canadian Diabetes Association Clinical Practice Guidelines Expert Committee. Canadian Diabetes Association 2003 clinical practice guidelines for the prevention and management of diabetes in Canada. *Can J Diabetes* 2003;27(Suppl 2):S7–9, S10–3, S18–20, S21–3.
59. Gallagher EJ, Bloomgarden ZT, Roith D. Review of hemoglobin A1C in the management of diabetes. *J Diabetes* 2009;1:9–17.
60. Goldenberg RM, Cheng AYY, Punthakee Z, Clement M. Position statement: use of glycated hemoglobin (A1C) in the diagnosis of type 2 diabetes mellitus in adults. *Can J Diabet* 2011⁽⁷⁾:247–9.
61. Ekmektzoglou KA, Zografos GC. A concomitant review of the effects of diabetes mellitus and hypothyroidism in wound healing. *World J Gastroenterol* 2006;12:2721–9.

CONTENTS

INTRODUCTION	69
GENERAL PRINCIPLES.....	69
CONTEXT	69
INDIVIDUALIZED APPROACH.....	69
INTERPROFESSIONAL TEAM	70
ASSESSMENT PRINCIPLES FOR THE 24-HOUR APPROACH	70
ASSESSMENT USING THE 24-HOUR APPROACH TO PRESSURE MANAGEMENT	70
Goal of the sitting assessment or reassessment	71
STEPS IN THE COMPREHENSIVE ASSESSMENT	71
1. Understanding the individual	72
2. Performing a physical assessment	72
3. Analyzing and interpreting the findings	73
4. Formulating a collaborative plan of action	73
CRITICAL ASSESSMENT CONSIDERATIONS	73
Positioning	73
Support surfaces	74
Mobility	74
Role of pressure mapping in pressure management.....	75
INTERVENTION PRINCIPLES FOR THE 24-HOUR APPROACH	75
DEVELOPING AN INTERVENTION PLAN	75
PRESSURE-REDISTRIBUTION STRATEGIES: TERMS AND DEFINITIONS	76
Pressure redistribution through functional movement	76
Active weight shifts	76
Dynamic weight shifts	76
REASSESSMENT	77
Pressure ulcer: an indication for reassessment and treatment	77
PREVENTION AND TREATMENT CONSIDERATIONS.....	78
Level of spinal cord injury	78
Higher cervical injuries	78
Lower cervical and upper thoracic injuries.....	79
Lower thoracic injuries	79
Continuum of care	79
Acute spinal cord injury phase	79
Rehabilitation phase	80
Community phase.....	81
Long-term spinal cord injury phase	81
CONCLUSION	82
REFERENCES.....	82

Introduction

The 24-hour approach to pressure ulcer prevention focuses on addressing the extrinsic forces of pressure, friction, shear, and microclimate — temperature and moisture — within the daily activities of the person over a full 24-hour day. The person's posture, positioning, mobility, and the support surfaces used during daily activities influence the extent to which these extrinsic factors affect the risk of pressure ulcers. Each person participates in a unique combination of activities that make up daily life. Individual differences in function, abilities, lifestyle, and goals are key considerations when assessing the presence and risk associated with extrinsic factors.



In the context of spinal cord injury, assessment and management of force and microclimate include comprehensive assessment of positioning, mobility, function, and support surfaces used by an individual throughout the entire 24-hour period to determine the combined influence of these extrinsic factors on overall management of force and microclimate and on skin integrity.^(1,2)

Modification of posture, positioning, mobility, and support surfaces used by the individual during the 24-hour day while ensuring function in daily life activities is maintained can manage the risk posed by these factors.

General principles

CONTEXT

Comprehensive assessment for 24-hour management includes sitting and recumbent positions, with attention to prevention of postural deformities, contractures, and pressure ulcers, and management of spasticity. Skin inspection before and after the use of specific positions and support surfaces is an essential evaluation to determine an individual's tissue tolerance and inform repositioning schedules and support surface recommendations.  **CHAPTER 2, *Human factors affecting pressure ulcer prevention, provides recommendations and discussion related to skin inspection.***

INDIVIDUALIZED APPROACH

Positioning and support surface recommendations over a 24-hour period must always be individualized, based on the following factors:

- Level of spinal cord injury and available functional movements
- Time in each position and on each surface
- Skin tolerance in response to repositioning intervals, changes in posture, support surfaces, and participation in daily activities
- Lifestyle and personal preference
- Movements and postures used to perform daily activities
- Comfort
- Presence or absence of a pressure ulcer

INTERPROFESSIONAL TEAM

Using the 24-hour approach to address microclimate and the extrinsic forces of pressure, friction, and shear within the person's daily activities requires advanced interprofessional clinical skills and is best performed by a specialized team. The primary team members for this area of pressure ulcer prevention are the occupational therapist and physiotherapist. It is crucial that at least one of these team members has expertise in specialized assessment and management of positioning and support surfaces for pressure ulcer prevention, typically seating, and one team member has expertise in assessment and treatment of people with spinal cord injury.⁽³⁾ These team members may be part of a formal team or may be consultants who provide the expertise in either or both areas to the primary team.

The way in which extrinsic factors influence risk for people with spinal cord injury differs significantly from that in able-bodied people and in the elderly.^(4,5)



As a result, the need for an interprofessional team with expertise in both spinal cord injury and pressure management is critical. Further interprofessional consultation may also be required with the physiatrist, wound-care clinician, nurse, and dietitian. Comprehensive assessment, which is vital for pressure ulcer prevention and treatment, provides important baseline information that is essential for developing an effective intervention plan.

4.1: Assessment of pressure and other sources of external force

Ensure that occupational therapy and/or physiotherapy members of the interprofessional team who have combined specialized training and experience working with people with spinal cord injury and in seating and positioning perform a comprehensive pressure management assessment, in consultation with other interprofessional team members.

RECOMMENDATION LEVEL IV

Assessment principles for the 24-hour approach

ASSESSMENT USING THE 24-HOUR APPROACH TO PRESSURE MANAGEMENT

4.2: 24-hour approach to pressure ulcer risk management

Perform a comprehensive assessment of posture and positioning to evaluate pressure ulcer risk. Consider all surfaces in both recumbent and sitting positions that a person uses to participate in daily activities over the entire 24-hour period.

RECOMMENDATION LEVEL IV



The occupational therapy and physiotherapy team members should perform this comprehensive assessment in consultation with other team members, as necessary. Comprehensive assessment and reassessment require the following evaluations⁽⁶⁾:

- Observation of the person in each position that will be assumed on all support surfaces to ensure tolerance of those positions
- Inspection of skin in weight-bearing areas before and after each position on all support surfaces
- Collaboration with the person to ensure comfort and function in all positions over 24 hours
- Observation of pressure-redistributing and -offloading movements on each support surface and confirmation of their effectiveness through palpation and, if available, objective tools, such as interface pressure mapping
- Observation of transitional movements on each support surface and between different support surfaces to determine an individual's ability to perform them without causing friction, shear, or trauma
- Observation of an individual's ability to perform the functional tasks necessary from each support surface
- Observation and assessment of equipment trial, where equipment is indicated, to determine effectiveness of pressure management, before obtaining equipment permanently

Goal of the sitting assessment or reassessment

The goal of the sitting assessment or reassessment is to determine appropriate interventions to correct or accommodate posture, depending on flexibility, while integrating the need to

- Understand the functional implications of postural support interventions
- Ensure pressure is redistributed or offloaded from targeted bony areas to prevent skin breakdown, especially considering any history of pressure ulcers and the influence of posture on wound location
- Provide adequate support over the entire 24-hour day
 - » In each position, both initially and as the individual becomes fatigued
 - » On all surfaces
- Address the impact of spasticity and spasticity management strategies in postural interventions
- Incorporate microclimate management considerations in the intervention
- Maintain passive range of motion of the joints of the body to allow proper posture.

STEPS IN THE COMPREHENSIVE ASSESSMENT

The steps in the comprehensive assessment presented here are important to guide the comprehensive assessment process while maintaining the focus on the individual. The following section describes the critical assessment considerations for positioning, support surfaces, and mobility using the 24-hour approach. The steps and critical considerations are presented sequentially but occur simultaneously in clinical practice.

1. Understanding the individual: The clinician gathers information during the assessment to understand the person, relevant issues, goals, functional abilities, lifestyle, and specific needs.

2. Performing the physical assessment: The clinician performs a physical assessment to investigate posture, balance, stability, mobility, and pressure redistribution. Photographs and video recordings provide useful objective evidence of baseline posture and positioning for comparison during follow-up.

3. Analyzing and interpreting the findings: The clinician analyzes assessment findings to identify factors contributing to pressure ulcer risk or development and to determine appropriate interventions to meet the individual's goals, function, and lifestyle needs. This process also determines required parameters for an equipment trial.

4. Formulating a collaborative plan of action: The clinician develops a plan of action, in collaboration with the person with spinal cord injury, to determine the most appropriate interventions. These may include equipment, education, modification of functional tasks, additional rehabilitation to upgrade physical or functional skills, and caregiver training. An important part of the plan is the equipment trial, which provides the opportunity to try the equipment in the person's environment to ensure it meets needs for function, mobility, pressure management, posture, positioning, and comfort. The plan should also include follow-up and scheduled times for reassessment.

 **APPENDIX 4** contains examples of specialized assessment forms.

1. Understanding the individual

A comprehensive assessment depends on a thorough knowledge of an individual and his or her functional abilities, environment, spinal cord injury level, resulting impairments, specific issues, and personal goals. Review of the person's history, communication with team members, and an interview with the person are essential to provide the preliminary information required to identify factors that may influence pressure ulcer risk, such as the following:

- *Functional management*, including daily roles and activities
- *Equipment*, including all surfaces used: purpose and condition of equipment, satisfaction with and effectiveness of performance, frequency of use, sitting tolerance and duration, sitting schedules for each surface
- *Mobility and transfers*, including devices and their specific use: current condition, age, make and model, and need for assistance to use them
- *Current pressure management practices*
- *Home environment*, including accessibility issues and compromises, and presence of family, friends, and caregivers in the home
- *Community environments and access*
- *Transportation*, including frequency, duration, and quality, such as smooth versus jarring ride
- *Behaviour*
- *Compromise between lifestyle and pressure management*
- *Individual goals*

 **CHAPTER 2**, *Human factors affecting pressure ulcer prevention*, provides information on how lifestyle, beliefs, and behaviours affect pressure-redistributing activities. **Chapter 6**, *Wheelchairs and other seating*, and **Chapter 7**, *Mobility, activity, and conditioning*, contain recommendations about automatic and intentional active movements and dynamic weight-shifting, respectively.

2. Performing a physical assessment

A physical assessment investigates posture, balance, stability, mobility, and pressure redistribution. It is important for the clinician to coordinate assessments on different surfaces to minimize the number of transfers and optimize efficiency.

 Information about components necessary for a comprehensive patient assessment are contained in the following chapters:

- **CHAPTER 2**, *Human factors affecting pressure ulcer prevention*
- **CHAPTER 5**, *Beds, mattresses, and recumbent positioning*
- **CHAPTER 6**, *Wheelchairs and other seating*
- **CHAPTER 7**, *Mobility, activity, and conditioning*

3. Analyzing and interpreting the findings

The analysis and interpretation use a problem-solving approach to correlate assessment findings from the posture, positioning, support surface, and mobility assessments in sitting and recumbency with the individual's goals, needs, and function to identify pressure ulcer risk factors or causes of an existing pressure ulcer. The analysis includes evaluation of the condition of the equipment currently being used and whether it meets the person's postural and support needs or requires modification, replacement of some components, or complete replacement.



It is critical to use the same comprehensive analytic process for each surface evaluated. Assessment results may be carried forward to other surfaces, but the analysis must be individually performed for each seating surface.

The clinician provides the person with the analysis and intervention options so that together they can prioritize issues to address, especially issues that may be contributing to pressure ulcer risk.

4. Formulating a collaborative plan of action

The action plan includes the equipment and strategies that are anticipated to best meet the prioritized needs identified through the analysis. A detailed report describes the information gathered, assessment results, analysis, and action plan, including the equipment trial or simulation and agreed-upon interventions. It is critical for the action plan to be developed in collaboration with the individual to

- Ensure that recommended strategies and equipment meet individual goals, perceived needs, and lifestyle criteria
- Achieve successful implementation and integration into daily life.

In developing a plan of action it is important to discuss the following:

- Issues and goals for support surfaces and equipment
- Strategies for integrating pressure management into the individual's daily routine
- Relative priority of identified issues
- Potential compromises between lifestyle considerations and pressure management
- Need for follow-up
- Plan for reassessment

 **CHAPTER 5**, *Beds, mattresses, and recumbent positioning*, contains information about recumbency management plans. **CHAPTER 6**, *Wheelchairs and other seating*, contains information about seating management plans. **CHAPTER 7**, *Mobility, activity, and conditioning*, contains pressure management plans.

CRITICAL ASSESSMENT CONSIDERATIONS

Positioning

Critical positioning considerations are the following:

- Ability to achieve optimal postural alignment and maintain it over time
- Impact of changes in postural alignment on weight-bearing surfaces during participation in daily activities
- Ability of each position to redistribute pressure or offload bony prominences
- Influence of gravity on posture over the 24-hour period
- Duration of time spent in specific positions

- Effectiveness and consistency of pressure-redistributing or -offloading movements in each position by the individual
- Effectiveness and consistency of transitional movements on the same surface or between different surfaces
- Potential for position changes to produce friction or shear at the interface
- Functional tasks that need to be performed in specific positions and the influence of those positions on both pressure and function

 **CHAPTER 5**, *Beds, mattresses, and recumbent positioning*, contains information about recumbent positioning for pressure ulcer prevention. **CHAPTER 6**, *Wheelchairs and other seating*, contains information about seated positioning for pressure ulcer prevention. **CHAPTER 7**, *Mobility, activity, and conditioning*, contains specific considerations for mobility.

Support surfaces

Critical support surface considerations are the following:

- Magnitude and duration of pressure loading on each surface
- Total contact area and weight-bearing tolerance over the surface area
- Pressure-redistributing or -offloading capabilities of the support surface, especially at bony prominences
- Effect of support surface composition on stability, balance, and positioning for mobility and function
- Effect of support surface on skin temperature and moisture accumulation, or breathability, at the interface
- Potential for the support surface to produce friction or shear with movement
- Ability of the individual to use the support surface in all applicable environments, such as the commode at home or in a hotel
- Durability and effectiveness of each support surface with continued use over time
- Maintenance requirements for continued effectiveness of a support surface

 **CHAPTER 5**, *Beds, mattresses, and recumbent positioning*, contains information about selecting appropriate beds and mattresses. **CHAPTER 6**, *Wheelchairs and other seating*, contains information about wheelchair seating and other seating surfaces. **CHAPTER 7**, *Mobility, activity, and conditioning*, contains specific considerations for mobility.

Mobility

Critical mobility considerations are the following:

- Physical impairments:
 - » *Sensation*: cutaneous, proprioceptive, and pain
 - » *Joints*: range of motion, or flexibility
 - » *Muscles*: flexibility and strength, tone and reflexes
 - » *Motor function*: selective control and coordination
 - » *Posture*: postural alignment, postural control, and dynamic balance
 - » Cardiorespiratory tolerance of activity
- Gross motor skills:
 - » *Bed mobility*: rolling, shifting, and repositioning
 - » *Transitional movements*: recumbent to long sitting, recumbent to high sitting, sitting to standing
 - » *Transfers*: to all functionally relevant surfaces
 - » *Wheelchair skills*: propulsion and pressure-redistributing movements
 - » *Ambulation*
- Movement quality:
 - » *Use of normal movement patterns*
 - » *Level of control and care during movements*: ability to prevent trauma in moving the body or limb onto or off different surfaces
 - » *Impact of fatigue*: deterioration in movement quality during the day or with muscle fatigue

 **CHAPTER 7, Mobility, activity, and conditioning, contains a comprehensive review of assessment and management of mobility.**

Role of pressure mapping in pressure management

4.3: Pressure mapping

Use pressure mapping results in conjunction with clinical findings and the individual's preference to select appropriate support surfaces and to optimize the type and duration of position changes.

RECOMMENDATION LEVEL IV

Pressure mapping systems, which are comprised of a sensor array in a flexible mat, measure interface pressures between the body and support surface. The pressure sensors are connected to a computerized system that displays the pressures measured at each sensor, using a colour-coded image and a number. These outputs display the level of pressure at each sensor, the overall amount of contact area for pressure distribution, and pressure asymmetries. Higher areas of pressure may indicate bony prominences, but manual palpation is necessary to confirm this.⁽⁷⁾

The results from pressure mapping need to be interpreted with caution, and clinicians using the technology need to be aware of the limitations of pressure mapping technology.⁽⁸⁾ Although limitations exist for pressure mapping in clinical practice, evidence supports its use as part of a full assessment to provide:

1. Visual feedback to educate clients about the impact of pressure and pressure changes with weight-shifting^(9,10)
2. Relative pressure comparisons on different cushions for the same person⁽⁹⁻¹¹⁾
3. Relative pressure changes with different body orientations in space, such as tilt^(11,12)
4. Relative pressure changes with different body postures, such as leaning or pelvic obliquity⁽¹³⁾

 *For more information on this topic, consult: Connolly SJ, Miller WC, Trenholm K, Titus L, Moir S, Coulson S, et al. Wheeled mobility and seating equipment for the spinal cord injured individual. In: Eng JJ, Teasell RW, Miller WC, Wolfe DL, Townson AF, Hsieh JTC, et al, eds. Spinal Cord Injury Rehabilitation Evidence, 2010. Version 3.0. Available at www.scireproject.com.*

Intervention principles for the 24-hour approach

DEVELOPING AN INTERVENTION PLAN

The interprofessional team analyzes the results of the assessment of recumbent and sitting positioning, support surfaces, mobility, and activity over the 24-hour period to develop individualized prevention and treatment interventions that can be integrated into an individual's daily life.⁽¹⁴⁻¹⁶⁾

If a pressure ulcer is present, the intervention addresses both prevention and treatment. An increase in pressure ulcer risk can be associated with a change such as new or modified equipment, lifestyle changes, and other challenges.^(17,18)

For this reason, education is a critical component of the intervention plan. Specific education about individual pressure ulcer risk factors, preventive strategies, and strategies to respond to risks is a central component of prevention interventions arising from each comprehensive assessment or reassessment.⁽¹⁹⁾ It is critical the person with spinal cord injury is



provided education about the influence of posture, positioning, repositioning schedules, and functional use of support surfaces on pressure ulcer development to facilitate the ability to identify early, superficial pressure ulcers and intervene rapidly to prevent or minimize progression.⁽²⁰⁾ The intervention plan should also include the following:

- Regularly scheduled reviews of recumbent and sitting positioning and support surfaces used for mobility and activity by the occupational therapy and physiotherapy team members
- Ongoing monitoring of skin, support surfaces, and changes in lifestyle, mobility, or health by the person with spinal cord injury

 **CHAPTER 2**, *Human factors affecting pressure ulcer prevention, contains information about skin inspection.*

PRESSURE-REDISTRIBUTION STRATEGIES: TERMS AND DEFINITIONS

4.4 Intervention: Pressure-redistribution strategies

Use a variety of pressure-redistribution strategies that are individualized to meet the person's needs and lifestyle. Provide timely and targeted education and reinforce effective pressure management strategies at every opportunity.

RECOMMENDATION LEVEL IV

Pressure-redistribution strategies may be intentional weight-shifting movements performed by the individual or may occur inherently or automatically as a result of daily activities. Intentional weight-shifting can be performed by active movements or with the assistance of technologies, and they may be performed by the individual or the caregiver.

Pressure redistribution through functional movement

Pressure redistribution through functional movement refers to situations in which pressure redistribution occurs naturally or automatically as a result of daily activities. The individual is likely not consciously thinking about the pressure redistribution, but different areas of the skin are exposed to varying tissue loads throughout the day, depending on the movement or activity. Skin protection inadvertently occurs as the result of functional movement. Provided the individual remains active, pressure is redistributed secondarily.  **CHAPTER 7**, *Mobility, activity, and conditioning, contains information about the benefits of daily activities and exercise in preventing secondary complications.*

Active weight shifts

Pressure can also be redistributed intentionally when an individual uses the upper body and/or arms to intentionally shift his or her weight. Such manoeuvres include side- and forward-leaning and whole-body lifts.  **CHAPTER 7**, *Mobility, activity, and conditioning, contains information and recommendations about intentional movements used for pressure redistribution, including weight shifts.*

Dynamic weight shifts

Manual and powered dynamic weight shifts include movements that redistribute pressure through the use of assistive technologies. These types of intentional weight shifts are performed manually when the individual or caregiver repositions a portion of the wheelchair or other assistive device, such as changing the back recline position. Dynamic weight shifts can be performed using powered support systems, such as power tilt, that the individual controls or activates. Dynamic weight shifts can help people who are unable to perform effective active weight shifts through the entire day.  **CHAPTER 6**, *Wheelchairs and other seating, contains recommendations for dynamic weight shifts involving assistive technology.*



REASSESSMENT

4.5: Reassessment

Reassess pressure management using a 24-hour approach every 2 years, or more often if a pressure ulcer develops or there is a significant change in health status — including weight changes or functional ability — or if there are changes in living situation or a deterioration in the support surface/equipment.

RECOMMENDATION LEVEL IV

Reassessment, a critical principle of the 24-hour approach to pressure management, should ensure the following:

- Support surface equipment remains suitable.
- Posture is monitored for changes that may affect function or pressure management.
- Altered levels of pressure ulcer risk are identified.
- Preventive pressure management strategies remain appropriate.

It is important to reassess earlier than 2 years in the following situations:

- Changes in:
 - » Medical or functional status
 - » Body weight
 - » Living circumstances, such as moving into an assisted-living facility
- Development of pressure ulcers
- Deterioration of equipment or support surfaces, which can reduce pressure management effectiveness

Comprehensive reassessment of positioning, support surfaces, mobility, and pressure management practices is important after any such change. Reassessment can achieve the following:

- Identify gradual changes in need that may go unnoticed by the person.
- Identify the impact of physical changes due to aging and increasing duration of spinal cord injury, including postural changes, muscle wasting, and spasticity.
- Review education on pressure management strategies and adaptation to changing circumstances.
- Ensure continuing effectiveness of support surfaces, positioning, and repositioning strategies in managing force and microclimate.
- Ensure appropriate modifications in positioning or support surfaces to meet changing abilities and needs.
- Compare postural assessments over time to identify and address deterioration early.
- Monitor equipment to ensure proper function, determine maintenance and repair needs, and identify need for replacement.

Pressure ulcer: an indication for reassessment and treatment

A comprehensive treatment plan for a pressure ulcer begins with a detailed assessment and includes the following:

- Strategies to address the etiology of the pressure ulcer, including:
 - » Management of force and microclimate
 - » Education
 - » Nutritional interventions
- Existing medical conditions and investigation to identify any new conditions
- Specific wound care
- Adjunctive therapies to support healing as necessary
- Surgery for complex or deep stage III and IV ulcers
- Management of complications

 **CHAPTER 9**, *Pressure ulcer treatment*, contains more detailed information on treatment of pressure ulcers.





The occurrence of a pressure ulcer in an individual with a spinal cord injury indicates the need for a thorough reassessment to uncover causative, contributing, and predisposing factors, including the following:

- Identification and investigation of underlying medical conditions
- Evaluation of nutritional status
- Review of repositioning schedules and skin checks
- Reassessment, collaboratively with the patient, of all support surfaces, posture and positioning in sitting and recumbent positions, pressure-redistributing and -offloading strategies, and transitional movements
- Analysis of lifestyle, environment, and any changes
- Review of any additional preventive pressure management strategies
- Review of gross motor skills and mobility

PREVENTION AND TREATMENT CONSIDERATIONS

Level of spinal cord injury

The neurologic level and completeness of the spinal cord injury affect pressure and postural management in a variety of ways:

- Partial or complete loss of sensation below the injury
- Muscle atrophy decreasing tissue bulk around bony prominences below the level of injury
- Partial or complete loss of trunk control and balance affecting the ability to maintain midline postures against gravity
- Need for external postural supports to achieve and maintain appropriate posture
- Partial or complete loss of the ability to weight shift and reposition to manage pressure
- Inability to regulate temperature normally below the level of injury
- Potential for asymmetrical muscle strength and control patterns further compromising the ability to maintain midline postures
- Presence of spasticity and influence of spasms on friction, shear, and posture

An individual's level of physical function determines the appropriate pressure-redistribution strategies, transfers, bed positioning, and skin check approaches. Regardless of an individual's level of injury, implementation of pressure management practices must be individualized and consider all factors contributing to the ability to function.

HIGHER CERVICAL INJURIES



Individuals with higher cervical injuries generally require caregiver or mechanical assistance for most pressure management practices, including repositioning strategies and transfers.

Higher levels of injury also increase the risk of postural deterioration.⁽²¹⁾ These individuals are dependent for balance, transfers, postural alignment on all support surfaces, and certain repositioning strategies. Important considerations for higher cervical injuries include the following:

- Education to develop independence in directing pressure management care
- Use of power positioning technology, in conjunction with power mobility, for certain repositioning movements
- Full postural support to maximize balance and stability on all support surfaces

LOWER CERVICAL AND UPPER THORACIC INJURIES

Individuals with lower cervical and upper thoracic injuries generally have partial arm function and a certain amount of trunk control.



Their degree of independence with balance, weight-shifting, repositioning movements, and transfers depends on the ability to learn compensatory strategies using parts of the body with preserved function.

Important considerations for lower cervical and upper thoracic injuries include use of the following:

- Effective pressure management strategies combined with assistance as necessary to maximize independence
- Postural supports that provide adequate support to maintain neutral alignment, especially if fatigue is a factor, but also permit enough dynamic movement away from a supported resting posture for function

LOWER THORACIC INJURIES

Individuals with lower thoracic injuries who have full strength and function in their arms and preserved trunk control and strength above the level of injury are capable of maintaining their posture with minimal trunk support and of performing most pressure management practices independently. Compensatory strategies are still required for balance, weight-shifting, repositioning movements, and transfers. The maintenance of a degree of dynamic movement and strength, however, allows these strategies to be fully effective for pressure management. An important consideration for lower thoracic injuries is use of pelvic postural supports, such as a low back support, to maintain pelvic alignment and stability in sitting without inhibiting dynamic movement.

Continuum of care

It is important that the assessment for 24-hour management of force and microclimate is sensitive to changing needs and issues that may arise across the continuum of care in an individual with spinal cord injury.

ACUTE SPINAL CORD INJURY PHASE

 **CHAPTER 1, *Pressure ulcer prevention and the interprofessional team, contains information about identifying individuals at risk of pressure ulcer development immediately after spinal cord injury.*** During the early post-injury phase, a recumbent support surface that provides maximum pressure redistribution, management of friction and shear, and frequent repositioning is usually required. A high incidence of pressure ulcers is seen during the acute phase.^(22,23) Development of a pressure ulcer during the acute phase of recovery after spinal cord injury increases the risk of additional pressure ulcers.⁽²⁴⁾ People should be turned at least every 2 hours initially, and skin should be checked between turns.⁽²⁵⁾ Adjustments to the turning interval are based on tissue tolerance and should be re-evaluated regularly. If the spine is not stabilized or the person is medically unstable, this approach may need to be modified. Until the spinal cord injury stabilizes, bed positioning, repositioning schedules, and support surfaces for recumbency are a higher priority than sitting.

 **APPENDIX 4, *Support surfaces, provides information about recumbent support surface selection.***

Ontario Health Technology Advisory Committee recommendations for pressure ulcer prevention, which are not specific to the population with spinal cord injury, specify a high-quality foam mattress for emergency room or acute care settings and a high-quality foam or gel support surface for surgical procedures more than 90 minutes in length, with the strongest evidence existing for gel pads in this setting.⁽²⁶⁾

When the team determines it is appropriate for an individual to begin sitting, the objective is to establish skin and sitting tolerance and monitor for development of complications, such as autonomic dysreflexia and hypotension, when an

individual is sitting upright against gravity. A structured and graduated sitting protocol with skin inspection before and after each sitting period is recommended.  **APPENDIX 5, *Graduated sitting protocol for pressure ulcer management, is an example of a graduated sitting protocol.***

In general, during the acute phase, individuals lack adequate strength and mobility to perform many functional tasks involved in independent pressure management. As a result, support surfaces used during the acute phase must provide

- Maximum pressure redistribution or offloading of bony areas vulnerable to skin breakdown
- Adequate stability for individuals to maintain positioning
- Mechanically operated manual or powered mechanisms for repositioning or weight-shifting, such as dynamic tilt-in-space wheelchairs.

For management of positioning and support surfaces during the acute phase, use the following:

- Graduated sitting protocols
- A tilt-in-space wheelchair until an effective alternative method of weight-shifting for pressure management has been established
- A cushion that provides a high level of pressure redistribution or offloading to bony areas of the pelvis and a high level of stability for postural support and alignment
- A backrest with posterior pelvic support and lateral supports for postural stability and alignment and a full-height profile for pressure redistribution and support in the tilted position
- Consideration of additional secondary supports, such as contoured arm troughs and a headrest, while a person's functional capabilities are developing

REHABILITATION PHASE

A person with spinal cord injury may leave acute care with a pressure ulcer. In addition, these individuals still have a high risk of developing pressure ulcers during rehabilitation. It is important to provide a support surface with the greatest amount of envelopment and immersion to redistribute pressure without affecting the person's ability to function in bed. Support surface selection must also consider comfort and prevention of friction and shear. If and when people are able to turn independently, it is important to teach them appropriate techniques and to cue them to reposition themselves to promote the development of independence. As people become more independent over time, they may also be able to inspect their own skin or instruct the caregiver.

As an individual's functional capabilities improve, positioning and support surface requirements change. The rehabilitation phase is generally the time during which an individual's strength, mobility, and functional performance improve the most. Changes to support surfaces and pressure management practices must be addressed along with these functional changes. As rehabilitation proceeds, the focus shifts to maximizing mobility and function and educating the person about pressure management behaviours and skin inspection. Equipment is downgraded to match increasing function, and turning intervals are extended as skin tolerance increases.



The interval between turns can be lengthened when hyperemia over bony prominences resolves within 30 minutes.

Education is a critical aspect of rehabilitation to support development of good pressure management habits. Vital topics include skin inspection, wheelchair skills, joint preservation, efficiency in mobility, ideal transfer practices, and self-management strategies. The complex nature of pressure ulcer development in different individuals means that education and pressure management strategies must be individualized and fully integrated into each person's daily life.  **CHAPTER 2, *Human factors affecting pressure ulcer prevention, contains information about education and self-management.***

Prescribing appropriate pressure management equipment to facilitate discharge from inpatient care occurs during rehabilitation. Ideally, once the person's function stabilizes, comprehensive assessment for 24-hour positioning and support surfaces allows individualized prescription of a wheelchair and seating components. At this stage, equipment prescription emphasizes function and pressure ulcer prevention. A critical part of the prescription process is the equipment trial to ensure the equipment meets the identified needs. The equipment trial includes trying the equipment within the individual's home environment to ensure the equipment and strategies meet functional and lifestyle needs at home after discharge.

COMMUNITY PHASE

During the transition to the community phase, the focus of assessment for 24-hour management of force and microclimate is to ensure pressure management practices and strategies learned during the acute and rehabilitation phases are incorporated into the person's daily life. It is critical to provide support and practical solutions for integrating self-management and skin monitoring into the daily routine.  **CHAPTER 2, *Human factors affecting pressure ulcer prevention, contains information about education and self-management.***

Support surface selection must reflect the person's goals and lifestyle for use of the surface to be continued long term. The environmental context is another important consideration, such as the need for a constant supply of electricity for powered surfaces. As individuals with spinal cord injury may no longer be connected to a rehabilitation centre, resources need to be available so that people can get help if problems develop.

Ongoing regular assessment by a specialized spinal cord injury pressure management team can monitor physical changes over an individual's lifespan and recommend modifications in pressure management practices. Regular inspection of equipment can detect deterioration of support surfaces and identify the need to upgrade equipment, increase support services, or change daily activities, to ensure continued effectiveness in pressure ulcer prevention.

LONG-TERM SPINAL CORD INJURY PHASE

Short-term illness or hospitalization can produce deconditioning, which affects mobility and function. Temporary changes in pressure management, positioning, and support surfaces may be required until the baseline functional level has been regained. Rehabilitation may be needed to maximize function and mobility.



The risk of pressure ulcers may increase over time due to changes in function, strength, and mobility that typically occur with increasing duration of spinal cord injury and with aging. Physical changes increase pressure ulcer risk and may require more intensive pressure ulcer management practices.

Changes due to long-term or permanent alterations in health status may also necessitate more frequent reassessment of positioning, support surfaces, and pressure management approaches. Upgrading equipment, increasing support services, or modifying functional movements, such as transfers, may be required to prevent pressure ulcer development over a person's lifespan.

CONCLUSION

Assessment for 24-hour management of pressure ulcer risk focuses on addressing the extrinsic factors of pressure, friction, shear, and microclimate encountered in daily life. The extent to which these extrinsic factors affect pressure risk is influenced by the person's posture, positioning, and support surfaces used during daily activities. These factors, combined with individual differences in function, abilities, lifestyle, and goals inform all aspects of the assessment and produce an individual intervention plan for pressure ulcer prevention and/or treatment. The specialized interprofessional spinal cord injury and pressure management team uses the 24-hour approach, combined with their clinical knowledge, advanced skills, and professional expertise, to provide people with spinal cord injury with the tools, strategies, and education to maintain skin integrity while participating actively in life.

REFERENCES

1. Lange ML, Waugh K. 24 hour postural management. *PM&R Update* 2004;9:1–4.
2. Norton L. Twenty-four hour postural management for adults. International Seating Symposium; Nashville, TN: March 3–5, 2011. Available at http://www.iss.pitt.edu/ISS_Documents/ISS2011proceedings.pdf. Accessed October 19, 2011.
3. Guihan M, Hastings J, Garber S. Therapists' role in pressure ulcer management in persons with spinal cord injury. *J Spinal Cord Med* 2009;32:560–7.
4. Regan M, Teasell RW, Keast D, Aubut JL, Foulon BL, Mehta S. Pressure ulcers following spinal cord injury. In: Eng JJ, Teasell RW, Miller WC, Wolfe DL, Townson AF, Hsieh JTC, et al, eds. *Spinal Cord Injury Rehabilitation Evidence*, 2010. Version 3.0. Available at <http://www.scireproject.com/>. Accessed December 10, 2011.
5. Gutierrez EM, Alm M, Hultling C, Saraste H. Measuring seat pressure, area, and asymmetry in persons with spinal cord injury. *Eur Spinal J* 2004;13:374–9.
6. Di Marco A, Russel M, Masters M. Standards for wheelchair prescription. *Aust Occup Ther J* 2003;50:30–9.
7. Stinson MD, Porter-Armstrong A, Eakin P. Seat-interface pressure: a pilot study of the relationship to gender, body mass index, and seating position. *Arch Phys Med Rehabil* 2003;84:405–9.
8. Stinson MD, Porter-Armstrong AP. Seating and pressure support needs of people with cancer in the cervix or rectum: a case series on the clinical usefulness of pressure mapping assessment. *Eur J Cancer Care* 2008;17:298–305.
9. Brienza DM, Karg PE, Geyer MJ, Kelsey S, Treffler E. The relationship between pressure ulcer incidence and buttock-seat cushion interface pressure in at-risk elderly wheelchair users. *Arch Phys Med Rehabil* 2001;82:529–33.
10. Makhous M, Priebe M, Bankard J, Rowles D, Zeigler M, Chen D, Lin F. Measuring tissue perfusion during pressure relief maneuvers: insights into preventing pressure ulcers. *J Spinal Cord Med* 2007;30:497–507.
11. Sprigle S, Maurer C, Holowka M. Development of valid and reliable measures of postural stability. *J Spinal Cord Med* 2007;30:40–9.
12. Hobson DA. Comparative effects of posture on pressure and shear at the body-seat interface. *J Rehabil Res Dev* 1992;29:21–31.
13. Connolly SJ, Miller WC, Trenholm K, Titus L, Moir S, Coulson S, et al. Wheeled mobility and seating equipment for the spinal cord injured individual. In: Eng JJ, Teasell RW, Miller WC, Wolfe DL, Townson AF, Hsieh JTC, et al, eds. *Spinal Cord Injury Rehabilitation Evidence*, 2010. Version 3.0. Available at www.scireproject.com. Accessed December 10, 2011.
14. Dover H, Pickard W, Swain I, Grundy D. The effectiveness of a pressure clinic in preventing pressure sores. *Paraplegia* 1992;30:267–72.
15. Kennedy P, Berry C, Coggrave M, Rose L, Hamilton L. The effect of a specialist seating assessment clinic on the management of individuals with spinal cord injury. *J Tissue Viability* 2003;13:122–5.
16. Karatas GK, Tosun AK, Kanath U. Center-of-pressure displacement during postural changes in relation to pressure ulcers in spinal cord-injured patients. *Am J Phys Med Rehabil* 2008;87:177–82.
17. Fogelberg D, Atkins M, Blanche EI, Carlson M, Clark F. Decisions and dilemmas in everyday life: daily use of wheelchairs by individuals with spinal cord injury and the impact on pressure ulcer risk. *Topics Spinal Cord Inj Rehabil* 2009;15:16–32.

18. Clark FA, Jackson JM, Scott MD, Carlson ME, Atkins MS, Uhles-Tanaka D, Rubayi S. Data-based models of how pressure ulcers develop in daily-living contexts of adults with spinal cord injury. *Arch Phys Med Rehabil* 2006;87:1516–24.
19. Consortium for Spinal Cord Medicine Clinical Practice Guidelines. Pressure ulcer prevention and treatment following spinal cord injury: a clinical practice guideline for health-care professionals. *J Spinal Cord Med* 2001;24(Suppl 1):S40–101.
20. Dunn R, Stander J. Pressure sores in spinal cord injury: active intervention saves costs. *SAJCC* 2008;24:8–12.
21. BrainandSpinalCord.org. Levels of spinal cord injury. Available at http://www.brainandspinalcord.org/content/levels_of_spinal_cord_injury. Accessed December 5, 2010.
22. National Spinal Cord Injury Statistical Center (NSCISC). Annual report for the model spinal cord injury care systems. Birmingham, AL: NSCISC; 2005. Model Spinal Cord Injury Care Systems.
23. Yarkony GM, Heinemann MW. Pressure ulcers. In: Stover SL, DeLisa JA, Whiteneck GG, eds. *Spinal Cord Injury: Clinical Outcomes from the Model Systems*. Gaithersburg, MD: Aspen Publishing; 1995.
24. Jaglal SB, Munce SEP, Guilcher SH, Couris CM, Fung K, Craven BC, Verrier M. Health system factors associated with rehospitalizations after traumatic spinal cord injury: a population-based study. *Spinal Cord* 2009;47:604–9.
25. Royal College of Nursing. Clinical practice guideline. The use of pressure-relieving devices (beds, mattresses and overlays) for the prevention of pressure ulcers in primary and secondary care. Available at http://www.rcn.org.uk/_data/assets/pdf_file/0007/109843/002444.pdf. Accessed June 25, 2011.
26. Ontario Health Technology Advisory Committee. OHTAC recommendation. Prevention and management of pressure Ulcers. October 2009.

CONTENTS

RECUMBENT POSITIONING	87
PRINCIPLES	87
Supine position	88
Preventing heel ulcers	89
Side-lying position	90
Prone position	91
Reclining position	92
Elevating the head of the bed	92
Sitting position in bed	93
INTERVENTION	94
Prevention of pressure ulcers during recumbent positioning	94
Bed repositioning	94
Prevention during acute care	95
Pressure management in individuals with a pressure ulcer	96
Avoiding sustained bed rest for pressure ulcer treatment	96
SUPPORT SURFACES	97
PRINCIPLES	97
Support surfaces for people with pressure ulcers	97
Reactive technologies	97
Active technologies	98
Selection considerations	98
Type of ulcer and goals of ulcer care	99
INTERVENTION	100
Support surface selection tools	101
Support surface selection	101
Reassessment	102
CONSIDERATIONS	103
Force and microclimate characteristics	103
Impact on function and safety	103
CONCLUSIONS	103
REFERENCES	104

Recumbent positioning

PRINCIPLES

5.1: Bed positioning

Ensure proper bed positioning by using devices and techniques that are appropriate for the type of support surface and mattress and the individual's health status.

- Use pillows, cushions, and positioning aids to:
 - » Bridge contacting tissues, including bony prominences
 - » Unload bony prominences
 - » Protect pressure ulcers and vulnerable areas of skin
- Do not use closed cut-outs in mattresses or donut-type cushions.

RECOMMENDATION LEVEL IV

Use hand checks and palpation to check for areas of high pressure or bottoming out by sliding your hand between the bony prominence (sacrum) and the support surface (**SEE FIGURE 1.**)

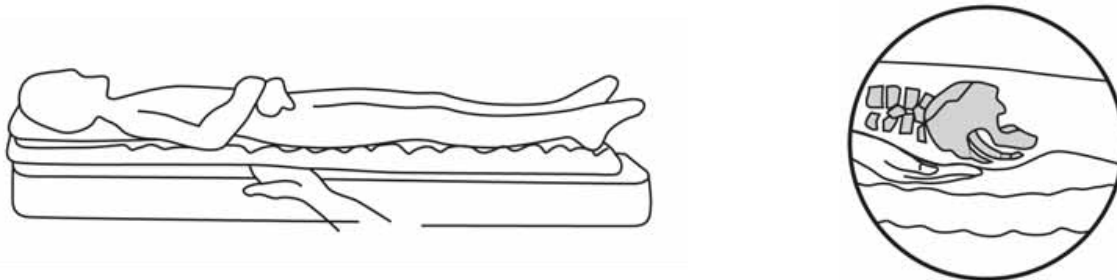

Figure 1. Using hand to check areas of high pressure or bottoming out in supine position. Note location of hand under sacrum.

It is important to prevent and treat pressure ulcers by ensuring people with spinal cord injury are always positioned properly in bed and by using positioning devices and techniques that are appropriate for the bed type and the individual's health status.



Do not use closed cut-outs or donut-type cushions, and avoid positioning an individual directly on a pressure ulcer.

Appropriately sized pillows, cushions, and wedge-shaped positioning aids are used to offload or bridge vulnerable areas. To counterbalance the negative influence of gravity on posture in the sitting position, use appropriate gravity-assisted recumbent positioning. Consider the ability of different support surfaces to facilitate positioning and function. For example, people with scoliosis benefit from a convex side-lying position to stretch the concave side, which is compressed in a sitting position. In general, people with spinal cord injury benefit from positions that inhibit or reduce spasticity, as minimizing involuntary movements reduces the risk of friction and shear. Postural support, stability, and positioning capabilities of a support surface also affect function, including transfers.



Confirm weight bearing and offloading of bony areas by both palpation and visual inspection in each position.

Education is critical, so that those checking the skin are able to recognize vulnerable skin and detect the early signs of skin damage, stage I pressure ulcers, and deep tissue injury. This education is especially important for individuals who must direct their own care. Care assistance is required and must be implemented when positioning independence is not feasible.  **CHAPTER 2**, Human factors affecting pressure ulcer prevention, provides information about skin checks.



Regardless of the pressure-redistribution capabilities of a bed or mattress, repositioning is still necessary to manage pressure.⁽¹⁾

Being aware of all positions that can be used on the support surface and alternating these positions can minimize pressure on any one area.



An experienced clinician who can evaluate the tissue response after a specific time in each position should determine repositioning frequency.

Education is required to ensure caregivers know how to carry out repositioning manoeuvres safely; place positioning devices, such as pillows and wedges, appropriately; and know how to avoid pinching catheter tubing and wrinkling clothing under weight-bearing parts of the body.

Supine position



5.2: Supine position

Use supine positioning to stretch and oppose sitting postures to maintain flexibility and skeletal alignment and reduce spasticity.

RECOMMENDATION LEVEL IV

- *Supine position*: Lying as flat as possible, for maximum stretching, on the back with shoulders back and legs extended.
- *Areas most vulnerable to skin breakdown*: Coccyx, sacrum, the posterior aspect of heels; elbows, scapulae, and occiput can also be affected (**FIGURE 2**).

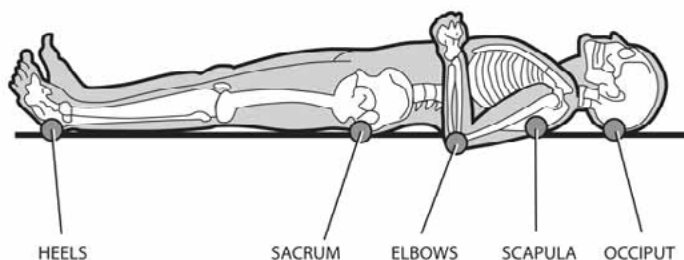

Figure 2. Areas vulnerable to pressure damage in the supine position

- *Areas offloaded*: Greater trochanters and ischial tuberosities, if pillows or supports are positioned appropriately. The ischial tuberosities are not usually weight bearing or vulnerable to pressure in a supine position. Flexing the hips and knees and supporting them with a wedge can offload these bony areas. However, a flexed-leg position in bed negates

the potential benefit of stretching the legs to counterbalance the sitting posture and can increase pressure on the coccyx and sacrum.

- *Recommendations for management in the supine position:*
 - » Avoid raising the head of the bed more than 30° (see Reclining position, P page 10).
 - » Ensure breathing is not compromised by lying flat.
 - » Offload the heels.

PREVENTING HEEL ULCERS

5.3: Heel ulcers

Consider a universal prevention program to protect the heels of all people with spinal cord injury while supine or reclined, especially people undergoing surgical procedures.

RECOMMENDATION LEVEL IV



Always minimize pressure on the heels in the supine position, especially on surfaces with low pressure redistribution capabilities, such as stretchers.

Loosely fitting sheets are important to prevent plantar flexion of the ankle, which can press the heels into the mattress. Place a cushion or wedge under the calves to elevate the heels from the surface of the bed. Additional support may be required to keep the foot in a neutral position and avoid prolonged plantar flexion (**FIGURE 3 AND 4**).



Test heel contact with the bed by sliding a sheet of paper between the heels and the bed.

A recent report found that heel ulcers could be eliminated when a universal prevention program was applied across an orthopedic service of an acute care hospital for all patients undergoing lower extremity joint surgery. The heel ulcer prevention program included staff education, early mobilization, and placement of a 1.5 inch wedge at the end of all 36 beds of patients who had undergone hip or knee replacement or hip fracture repair.⁽²⁾



Figure 3. Elevating the heels with a wedge

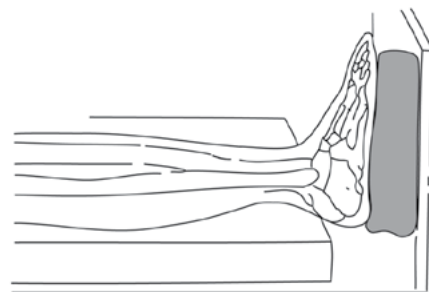

Figure 4. Protecting the heels using the end of the bed

Side-lying position



5.4: Side-lying position

Use a side-lying position at a 30° angle from supine that does not position the person directly on either hip.

RECOMMENDATION LEVEL IV

- **30° side-lying position:** Rotated 30° toward the right or left from supine, with a pillow or wedge behind the trunk to maintain this rotation and a pillow between the legs to maintain alignment and prevent bony prominences from weight bearing against each other (**FIGURE 5**).



Figure 5. Recommended 30° side-lying position

- **Areas most vulnerable to skin breakdown:** Sites on the side of the body lying against the support surface, including the greater trochanter, ischial tuberosity, lateral malleolus, elbow, and scapula, plus the medial side of both knees.

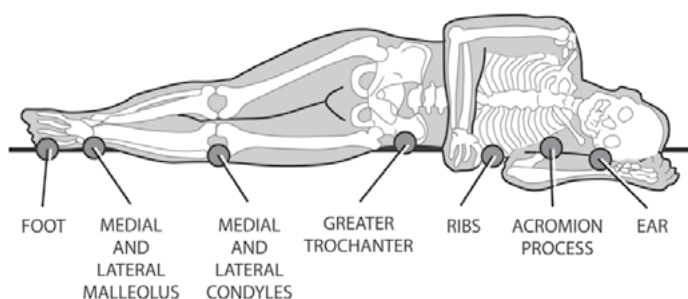

Figure 6. Areas vulnerable to pressure damage in the side lying position

- **Areas offloaded:** Sites on the side of the body not contacting the support surface, including the greater trochanter, ischial tuberosity, lateral malleolus, lateral condyle, and scapula. Depending on an individual's pelvic orientation and posture, the 30° side-lying position may reduce pressure over the coccyx and sacrum. This position may not, however, completely prevent weight bearing on these areas. Visual inspection and palpation of these bony landmarks is required to confirm offloading in this position. **CHAPTER 2, Human factors affecting pressure ulcer prevention, contains information about performing skin checks.**

- **Recommendations for management in the side-lying position:**

- » Avoid positioning individuals directly on the side, as it places significant pressure on the greater trochanter.
- » Flex the hips and knees slightly for comfort, and ensure the arm resting against the support surface is not pressed under the person's body.
- » Always perform a hand check for areas of excessive pressure or bottoming out by sliding your hand between bony prominences and the support surface.

Prone position

5.5: Prone position

Use prone positioning to stretch the hips and trunk while offloading the buttock region, including the ischial tuberosities, sacrum, and coccyx.

RECOMMENDATION LEVEL IV

- **Prone position:** Lying flat on the stomach with the head turned to one side.
- **Areas most vulnerable to skin breakdown:** Anterior pelvis, including the pubic symphysis and anterior superior iliac spines, toes and tops of the feet, knees, and elbows (Figure 7). Protect these areas by placing cushions under the head, chest, hips, and knees (FIGURE 8).

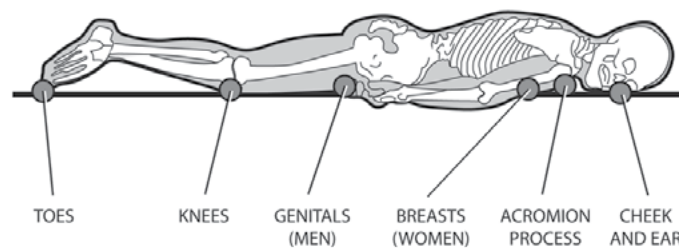

Figure 7. Areas vulnerable to pressure damage in prone position

- **Areas offloaded:** Coccyx, sacrum, ischial tuberosities, greater trochanters, heels, ankles, scapulae, spinous processes, and occiput.
- **Recommendations for management in the prone position:**
 - » Place a pillow under the lower abdomen to prevent hyperextension of the lumbar spine.
 - » Ensure the person has sufficient pain-free range of motion of the neck rotation to sustain a left- or right-rotated head position.

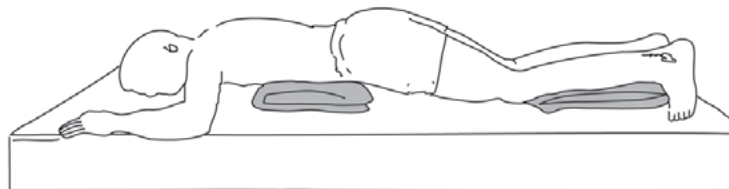

Figure 8. Recommended prone positioning

This position opposes the effects of gravity in sitting postures through passive stretching, counterbalances flexion from sitting, and promotes stretching of the hip flexors. Although the prone position limits function and is therefore not usually used for long durations, consider this position more often as a positioning alternative for people with spinal cord injury.



Prone lying may not, however, be feasible for all individuals, based on neck stability and flexibility, comfort, the presence of ostomy sites on the abdomen, or certain bladder management methods. It is also important to select an appropriate pillow for the head that keeps the neck in a relatively neutral position and does not interfere with breathing.

Reclining position

- **Reclining position:** Lying on the back with the head elevated above the body.
- Areas most vulnerable to skin breakdown: Coccyx, sacrum, back; heels can be affected if the patient must use feet to prevent sliding down in the bed.
- Areas offloaded: Greater trochanters, arms, and shoulders. Ischial tuberosities may or may not be offloaded, depending on the amount of elevation of the head of the bed.
- Recommendations for management with the head of the bed elevated:
 - » Avoid this position unless medically necessary, such as for management of pneumonia, swallowing problems, or heart failure.(1,3–5) friction and shear in the buttock region by placing a pillow or foam wedge under the knees and/or using the gatch feature on an electric bed to help support the person and flex the hip and knees.
 - » Confirm, using a hand check and palpation, that the support surface has not compressed to less than 1 inch below the coccyx and sacrum.
 - » Consider a transfer to a chair if this position is being used for extended periods of time, as the person may be able to function more effectively.
 - » Provide heel protection and avoid using the heels to reposition in the bed.

ELEVATING THE HEAD OF THE BED



5.6: Elevating the head of the bed

Avoid elevating the head of the bed above 30°. If raising the head of the bed is medically necessary, limit the amount of time in this position as much as possible.

RECOMMENDATION LEVEL IV



Positioning with the head of the bed elevated more than 30° can produce destructive friction and shear (FIGURE 9), especially in the sacrococcygeal region.

Many support surfaces are not designed to appropriately redistribute pressure when placed in the reclining position.⁽⁶⁾ A prospective crossover comparison of two alternating-air-pressure mattresses in individuals with spinal cord injury found that interface pressure measured at the sacrum significantly increased when the head of the bed was raised to 45° on both surfaces.⁽⁷⁾



Figure 9. Friction and shear with head of the bed elevated

The reclining position is not recommended for extended periods of time. Some electric beds have dials that read the angle of the head of the bed so that it is apparent when this level of elevation is exceeded. Some heart or lung conditions require the head of the bed to remain elevated to assist breathing. Gravity-assisted tube feeding also requires the person's head to be elevated. When it is necessary to use a reclining position, adding pillows and other positioning supports to prevent sliding down in the bed can help reduce friction and shear and protect vulnerable areas in the buttock region.

Sitting position in bed

5.7: Sitting in bed

Avoid sitting in bed. Transfer the person to a sitting surface that is designed to distribute pressures properly in the seated position.

RECOMMENDATION LEVEL IV

- *Sitting position in bed*: The head of the bed is elevated to 90°.
- *Areas most vulnerable to skin breakdown*: Ischial tuberosities, sacrum, and coccyx.

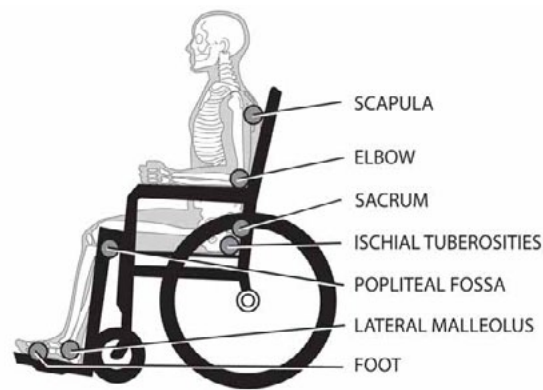

Figure 10. Areas vulnerable to pressure damage in sitting position

- *Areas offloaded*: Greater trochanters, knees, lateral ankles, scapulae, and arms.
- *Recommendations for management*:
 - » This position is not recommended for most beds and mattress surfaces.
 - » Provide education that explains why sitting in bed is not recommended.
 - » Use a hand check to identify areas where the support surface has compressed to less than 1 inch (bottomed out).
 - » Consider a transfer to a wheelchair or an alternative sitting support surface, if the person tolerates an upright position.

Most bed and mattress systems are not designed for use in the sitting position. Many mattress-pressure-redistribution properties are lost or significantly compromised when the head of the bed is elevated to near 90°. If sitting in bed is necessary for a medical procedure, conducting an assessment, eating, or swallowing, it is important to return the person to another position as soon as possible. If a sitting position is preferred, then transfer the person to a seating system.



INTERVENTION

Prevention of pressure ulcers during recumbent positioning

Prevention of pressure ulcers requires careful attention and individualization of recumbent support surfaces, positioning, repositioning, and transfers. Preventive strategies include the following:

- Ensuring the person practises good pressure management.
- Establishing realistic long-term positioning and turning schedules.
- Ensuring the person understands the importance of early detection and rapid reassessment to treat any pressure damage before it worsens. Familiarity with skin status is critical for the person to be able to identify potential problems.



Placing people with spinal cord injury on a therapeutic support surface to treat an existing pressure ulcer does not eliminate the risk of new pressure ulcers.

Studies that evaluated new support surfaces with advanced pressure redistribution properties have actually documented increased pressure ulcer incidence⁽⁸⁾. These surprising results were attributed to incorrect assumptions that people using mattresses with advanced pressure redistribution characteristics no longer required frequent repositioning.⁽⁹⁾ This outcome highlights the importance of maintaining repositioning intervals, even on therapeutic support surfaces with good pressure distribution characteristics, and of carefully monitoring skin and ulcer status.⁽¹⁰⁾  **CHAPTER 2, *Human factors affecting pressure ulcer prevention, contains information on skin inspection and strategies to encourage people with spinal cord injury to implement skin inspection and other preventive strategies.***

BED REPOSITIONING



5.8: Repositioning schedule

If the person's medical condition allows, turn and reposition individuals who require assistance at least every 2 hours, initially. Adjust the repositioning schedule based on the individual's skin response, determined by frequent skin checks, until an appropriate repositioning schedule is established.

RECOMMENDATION LEVEL IV

Several guidelines on pressure ulcer prevention stress the importance of repositioning schedules for people with a risk of pressure ulcer development.^(1,3,4) Although studies have shown that pressure ulcer prevention programs are effective in reducing the incidence of pressure ulcers in the spinal cord population,⁽¹¹⁾ the role of a defined turning schedule was not specifically evaluated. Clinical trials performed on a small sample of the general population have not produced conclusive results.⁽¹²⁾



The optimal repositioning interval is unknown, but 2 hours is widely recognized as effective, and this interval serves as a clinically useful initial interval when developing an individualized repositioning schedule.

The Registered Nurses' Association of Ontario and the Royal College of Nursing recommend that the results of the skin inspection determine the repositioning interval or turning schedule.^(3,5)

A recent review found the practice of 2-hour turning schedules is based more on folklore rather than research evidence.⁽¹²⁾ Only limited data and little new evidence address positioning and repositioning frequency.⁽¹²⁾ Factors affecting the appropriate repositioning frequency for an individual include the type and age of the support surface, function,

lifestyle, and individual skin tolerance. It is important to develop, display prominently, and use individualized positioning regimens and repositioning schedules.

In a review article, Sprigle and Sonenblum⁽¹³⁾ concluded, “Despite efforts by a number of researchers to identify the origins of this practice, or at least identify evidence supporting the 2-hour turning practice, no strong scientific support exists.”

Research is required on the following aspects of turning intervals:

- *Optimal repositioning intervals for prevention*
- *Alterations for treatment*
- *Implementation, given the reality of resource constraints*
- *Protocols to upgrade or downgrade the turning interval as people with spinal cord injury transition along the continuum of care*

A cohort study compared the effect of a 2-hour pressure-loading duration on skin temperature and sacral blood flow in three groups: participants with acute spinal cord injury, people with acute orthopedic trauma, and healthy subjects.⁽¹⁴⁾

The investigators found evidence of microvascular dysfunction in people with acute spinal cord injury, suggesting the current practice of turning people every 2 hours may need re-evaluation in people who have recently sustained a spinal cord injury.

Limited recent unpublished evidence suggests that people using a high-quality foam mattress may be turned less frequently, at a minimum of every 4 hours. The Ontario Health Technology Advisory Committee recommends that, until better evidence is available, all individuals restricted to bed be repositioned every 2 hours, or more frequently if they have a high risk of pressure ulcers, including people with spinal cord injury.⁽¹⁵⁾

5.9: Repositioning techniques

Use repositioning techniques that prevent injury to the caregiver and reduce friction and shear of soft tissues when individuals are moved.

RECOMMENDATION LEVEL IV

Skin injuries can occur during repositioning if movements are made too quickly or forcefully. Skin tears can result if caregivers pull, pinch, fold, or bump vulnerable skin areas repeatedly.  **CHAPTER 7, *Mobility, activity, and conditioning, discusses principles to increase the safety of repositioning and minimize the risk of injury to the person and the caregiver.***

PREVENTION DURING ACUTE CARE

The first few hours and days after spinal cord injury are associated with a high pressure ulcer risk.⁽¹⁶⁾ A high incidence of pressure ulcers has been reported during acute and early rehabilitation phases of recovery after spinal cord injury^(17,18) In addition, people who develop a pressure ulcer during the acute phase of rehabilitation have a greater risk of recurrent problems with skin breakdown throughout their life.⁽¹⁹⁾ Studies have found that people admitted to specialized spinal cord injury units within a week of spinal cord injury were less likely to develop pressure ulcers than those admitted after more than a week.^(20,21)

The higher risk of pressure ulcers was related primarily to the duration of unrelieved pressure before admission to acute care and to the time spent immobilized on a spinal board.  **CHAPTER 1, *Pressure ulcer prevention and the interprofessional team, contains recommendations about the use of spinal boards and pressure ulcer prevention.*** Pressure ulcers also frequently occur in older people with spinal cord injury when they are admitted to acute care for treatment of an acute illness or require surgical intervention.



An intervention study in an acute spinal cord injury unit assessed the effect of a motivated and educated turning team and routine use of pressure redistribution mattresses on reducing the development of new pressure sores.⁽¹¹⁾ The study found this strategy prevented development of any new pressure ulcers. The finding underscores the importance of pressure ulcer prevention in the acute setting and the effectiveness of simple preventive strategies.

Pressure management in individuals with a pressure ulcer

Pressure should be redistributed from a pressure ulcer at all times, and equipment used should prevent the development of additional ulcers. Support surfaces may require upgrading, especially if the surface contributed to pressure ulcer development. Wait time can be a challenge in scheduling an appointment with the clinician who can recommend the appropriate equipment and access the necessary funding. Funding can be a significant challenge on its own.

Effective pressure ulcer treatment may require temporary changes to an individual's level of independence, functional management, support surfaces and equipment, and pressure management practices. As these changes may have long-term functional implications, it is important to reassess overall management regularly during pressure ulcer treatment.

People with spinal cord injury have a great risk of developing a second pressure ulcer during pressure ulcer treatment. As a result, in addition to treatment interventions related to pressure management, appropriate preventive interventions need to be developed and implemented for all at-risk areas of the body to maintain skin integrity. It is therefore critical to monitor skin and ulcer status frequently and carefully, to implement appropriate positioning, and to maintain optimal repositioning intervals, regardless of the therapeutic support surfaces used.

During pressure ulcer treatment, skin should be inspected before and after each positioning interval on a support surface to determine the skin response to changes in repositioning schedules and support surfaces. As changes in positioning and repositioning schedules may limit or eliminate certain positions from use, it is important to monitor all vulnerable skin areas.

Avoiding sustained bed rest for pressure ulcer treatment



5.10: Bed rest for pressure ulcer treatment

Avoid prolonged use of full-time bed rest to treat pressure ulcers in individuals with spinal cord injury. Use bed rest, if necessary, to offload pressure completely for a specific and limited time, such as after surgical repair of pressure ulcers.

RECOMMENDATION LEVEL IV

Bed rest as a treatment for pressure ulcers can be associated with numerous physical complications; various psychological complications, such as anxiety, depression, and learned helplessness; and cognitive changes.⁽²²⁾ Furthermore, reconditioning takes longer than deconditioning. A review of the literature describing bed rest as a treatment modality in a variety of populations listed the following complications:

... contractures, muscle atrophy, osteoporosis, pathologic fractures, urinary tract infections, decreased cardiac reserve, decreased stroke volume, resting and post-exercise tachycardia, orthostatic hypotension, pulmonary embolism, deep venous thrombosis, pneumonia, anorexia, constipation, and bowel impaction ... the complications of bed rest are not only physical; psychological complications have been documented as well.⁽²²⁾

Many experts working in the field do not support the use of full-time bed rest to treat pressure ulcers in people with spinal cord injury.⁽²²⁾ On the contrary, the range and importance of the documented progressive deterioration in body and organ systems associated with bed rest makes this treatment alternative a last resort for most people with spinal cord injury. Bed rest is, however, recommended for 4 to 6 weeks after flap surgery.  **CHAPTER 9, Pressure ulcer treatment, provides information on postoperative care of a person with a pressure ulcer.** People with spinal cord injury may also need to stay in bed for a short time when they are acutely ill.

If bed rest has been used for treatment, it should be re-evaluated frequently and discontinued as soon as medically feasible. It is also necessary to develop and implement a remobilization and reconditioning plan, including a graduated sitting protocol to help the person regain lost ground. Readmission to rehabilitation may be required to prevent progressive functional decline and support the individual in regaining independence.

If the pressure ulcer can, however, be offloaded in a sitting position and transfers do not traumatize the pressure ulcer site, then a closely monitored sitting protocol can assist with pressure ulcer healing and prevent the negative consequences associated with prolonged bed rest.  **APPENDIX 5** provides an example of a graduated sitting protocol.

5.11: Sitting schedules for pressure ulcer treatment

Evaluate the individual's postural alignment, weight distribution, balance, stability, and pressure-redistributing capability to establish an appropriate sitting schedule.

RECOMMENDATION LEVEL IV

The main alternative to bed rest is thoroughly assessing factors contributing to pressure ulcer development and implementing an effective pressure management program using a 24-hour approach.⁽²³⁾  **CHAPTER 4, Principles of pressure management, contains a description of the 24-hour approach to pressure management.** The person with spinal cord injury requires a sitting system that adequately manages pressure. A modified sitting protocol with intermittent bed rest may be useful in this context. Similarly, advanced wheelchair cushions and tilt-and-recline wheelchairs may be effective in offloading the area of the ulcer in a sitting position.⁽²⁴⁾

Support surfaces

PRINCIPLES

 **APPENDIX 4** contains Terminology and definitions for support surfaces proposed in the National Pressure Ulcer Advisory Panel Support Surfaces Initiative (Version 01/29/2007).⁽²⁵⁾ These terms and definitions are used in this guideline.

Support surfaces for people with pressure ulcers

REACTIVE TECHNOLOGIES

A reactive support surface is “a powered or non-powered support surface with the capability to change its load distribution properties only in response to applied load.”⁽²⁵⁾

- **Foam:** Usually this refers to a mattress made of single piece of foam, covered by a plastic or nylon cover. Many facilities use foam as a standard mattress for all patients, regardless of risk.
- **High-specification foam:** This alternative may be foam layers of different densities or a multi-zoned surface, with sections of foam that can be removed temporarily to eliminate pressure on a specific area. Varying combinations of foam, gel, and air-filled cells may be used. This type of support surface is available in mattresses and overlays for beds, stretchers, and operating room tables.



- **Reactive flotation:** This technology maintains constant low pressure and moulds around the person to redistribute pressure over large areas.
 - » *Fibre:* Synthetic fibres coated with silicone or made into small spheres are arranged in a series of connected cells to reduce friction and shear. Depending on the covering material, this type of support surface may provide microclimate control.
 - » *Fluid:* These surfaces conform to body contours, reducing pressure and shear.
- **Gel and viscoelastic foam:** Pads and overlays are often used in the operating room to protect the head, feet, and ankles.
- **Australian Medical Sheepskins:** Evidence suggests medical-grade real sheepskin overlays decreased pressure ulcers compared with standard hospital foam mattresses, due to a reduction in pressure, friction, shear, and moisture. Synthetic sheepskin should never be used as an alternative to medical-grade real sheepskin. Mistiaen et al ⁽²⁶⁾ performed a multilevel analysis of three randomized controlled trials (27–29) of the effect of Australian Medical Sheepskins on the incidence of sacral pressure ulcers in hospitalized patients. Study participants did not have spinal cord injury. This meta-analysis ⁽²⁶⁾ included 1,281 patients at 11 institutions. The main outcome measure was the incidence of sacral pressure ulcers. In the control group, the incidence of sacral pressure ulcers was 12.2%, compared with 5.4% in the intervention group. Analysis of the data in a conventional meta-analysis gave an odds ratio (OR) of 0.37 (95% confidence interval [CI] 0.17–0.77) for the sheepskin group. The multilevel binary logistic regression based on combined individual data gave an OR of 0.35 (95% CI 0.23–0.55).

ACTIVE TECHNOLOGIES

An active support surface is “a powered support surface with the capability to change its load distribution properties, with or without applied load.”⁽²⁵⁾

- **Alternating air pressure:** This technology is available with large or small cells, and it may be available in mattresses and overlays for beds, chairs, or replacement mattresses.
- **Low air loss:** Continuous airflow from the entire mattress surface, with maintenance of air cell inflation, helps to manage microclimate. It is available as overlays, mattresses, and complete bed systems.
- **Air fluidized (high air loss):** Air flows through beads or grains, creating dry flotation for individuals who cannot tolerate pressure. An air-permeable cover promotes moisture evaporation and temperature control.

Selection considerations

Support surface performance characteristics and applications may differ substantially (**TABLE 1**).^(3,4) Essential considerations in selecting a support surface include the following:

- **Time:**
 - » Total and consecutive number of hours spent on the bed over a 24-hour period
- **Pressure:**
 - » Pressure redistribution capability of the mattress at high-risk bony prominences
 - » Offloading capability of the mattress and any positioning aids used
 - » Ability of the support surface to adapt to weight fluctuations and position changes while maintaining its pressure redistribution characteristics
- **Microclimate:**
 - » *Moisture reduction* or permeability, including the ability of the support surface to manage fluids from incontinence, wound exudates, sweat, and spills
 - » *Temperature regulation*, including the ability of the support surface to prevent increases in tissue temperature, which can cause sweating, over the time it is used
 - Support surfaces with a high degree of immersion and envelopment can increase temperature at the body–support surface interface.
 - Support surface materials and cover materials can affect temperature differently.

- » *Multiple layers between the support surface and the individual, including clothing choices or soaker pads.*  **CHAPTER 6, *Wheelchairs and other seating, provides recommendations about the use of additional layers of padding over support surfaces.***
 - Layers may increase body temperature, causing sweating.
 - If layers are wet with urine, maceration may occur.
- **Friction:**
 - » Fabrics have a differing intrinsic ability to produce friction, which can affect pressure management during transfers and repositioning:
 - Wet fabrics produce more friction than dry fabrics.
 - Rough fabrics produce more friction than smooth fabrics.
 - The degree of friction at the person–support surface interface is a determinant of the risk of trauma during movement.
- **Function and lifestyle:**
 - » Tasks to be accomplished from the surface
 - » Ability of the person to transfer and reposition on the surface:
 - Active support surfaces are usually significantly more unstable than reactive support surfaces.
 - Instability can negatively affect mobility, repositioning, and function.
- **Environmental context:**
 - » Partners who sleep in the same bed as the person with spinal cord injury
- **Lifespan:**
 - » Effectiveness of the support surface over time when pressure loading is applied, such as compression of foam or migration of gel:
 - Relevant considerations include warranty, expected lifespan, maintenance, and need for reassessment of the support surface.
- **Individual tolerance:**
 - » Numerous factors, including comfort, preference, impact of noise, potential risk of dehydration with low-air-loss surfaces, and individual skin response
 - » Differences in pressure redistribution between mattresses in the same category for different individuals
 - » Risk of pressure ulcers and current number of pressure ulcers
 - » Type of ulcer and goal of care: healable, nonhealable, maintenance, or palliative ulcers (see Type of ulcer and goals of ulcer care)
- **Safety issues:** Beware of entrapment of the patient between the edge of the mattress and side rails. Mattresses are sized to fit specific bed frames. The height of a bed frame may place the patient at risk of a fall with transfers. Falls can also occur when side rails are not used for protection.

TYPE OF ULCER AND GOALS OF ULCER CARE

The goals of care for an ulcer may differ, depending on the individual and the situation. Healing may not always be the goal of ulcer management, even when the ulcer has the potential to heal. Pressure ulcers can be categorized according to their ability to heal, as follows⁽³²⁾:

- *Healable: A healable ulcer has had the causes corrected, and the ability to heal is present. No biological factors to prevent healing are present. For example, the blood supply is adequate.*
- *Maintenance: A maintenance ulcer has the ability to heal, but it is not healing due to problems with care. The patient may not adhere to treatment conditions, or the healthcare system may be unable to provide an element of care needed for healing.*
- *Nonhealable: A nonhealable ulcer lacks biological factors necessary for healing, such as adequate blood supply or nutrition.*
- *Palliative: A palliative ulcer is an ulcer in a palliative care patient. Whether or not the ulcer is healable, the overall goal of care is to maintain quality of life and dignity by providing good wound care, maximizing independence, and optimizing pain management.*

Table 1. Overview of Bed Support Surfaces

CATEGORY	TYPES	PERFORMANCE CHARACTERISTICS	APPLICATIONS
Reactive	Foam	Standard support area Some pressure redistribution No shear or microclimate management Routine transfers	Pressure ulcer prevention or Treatment of uncomplicated pressure ulcer for high-specification foam or static flotation
	High-specification foam	Increased support area Pressure redistribution No reduction in shear No microclimate management Routine transfers	
	Static flotation Air, gel or water	Increased support area Pressure redistribution and shear reduction No microclimate management May affect transfers Gel and water heavy to move	
Active	Alternating air pressure	Increased support area Pressure and shear reduction No microclimate management Routine transfers	Pressure ulcer prevention or treatment: Pressure ulcers on multiple turning surfaces Failure to heal on static support Postoperative pressure ulcer repair Greater pressure reduction than static
	Low air loss	Increased support area Pressure and (possibly) shear reduction Microclimate management Increased complexity of transfers	Failure to heal on alternating air pressure Pressure ulcer treatment when > 1 turning surface impaired
		Increased support area Pressure and shear reduction Microclimate management but Premature drying of moist dressings Difficult transfers and reduction in function	Pressure ulcer treatment after flap surgery or Deterioration of multiple trunk pressure ulcers

INTERVENTION

When selecting a support surface, the first step is a comprehensive analysis of individual needs.  **CHAPTER 4, Principles of pressure management, discusses this topic.** The type and age of the support surface may affect the positioning schedule. Proper maintenance of support surfaces is critical for optimal equipment performance, as equipment malfunctions can rapidly produce pressure damage if undetected. Fluidized support surfaces redistribute pressure away from bony prominences, which can reduce the risk of deep tissue injury, but they can also reduce postural stability and function.



Support surface selection key considerations:

- Time
- Pressure
- Microclimate
- Friction
- Function and lifestyle
- Lifespan
- Individual tolerance

Support surface selection tools

Several support surface selection tools are available to help clinicians decide on the best recumbent surface for their patients.

 **APPENDIX 4** includes the following support surface clinical guides:

- Support surface selection tool
- Reactive support surface selection
- Active support surface selection

Unfortunately, none of these tools have been validated and they have only been used to a limited extent for people with spinal cord injury. Therefore, no recommendation can be made about them.

Support surface selection

5.12: Support surfaces

Use a support surface with advanced pressure-redistributing properties, compared with a standard hospital foam mattress, to minimize peak pressure areas around bony prominences and protect soft tissue from bruising and injury.

RECOMMENDATION LEVEL IV

Support surfaces with advanced pressure redistribution properties minimize peak pressure around bony prominences and protect soft tissue from bruising and injury. It is important to re-evaluate the suitability of a support surface for pressure ulcer prevention if the person's medical condition changes.

5.13: Reactive Support surfaces

Select a reactive support surface for individuals who can be positioned without weight bearing on an ulcer and without bottoming out on the support surface.

RECOMMENDATION LEVEL IV

5.14: Active support surfaces

Select an active support surface if the individual cannot be positioned without pressure on an ulcer, when a reactive support surface bottoms out, if there is no evidence of ulcer healing or if new ulcers develop.

RECOMMENDATION LEVEL IV

5.15: Mattress Replacement

Replace the existing mattress with a support surface that provides better pressure redistribution, shear reduction and microclimate control in the following situations:

- Pressure ulcers on multiple turning surfaces
- Compromised control of microclimate in the presence of deep tissue injury
- Person cannot be positioned off the ulcer
- They are a high risk of developing additional ulcers
- Failure to heal or wound deterioration
- Bottoms out on the existing support surface

RECOMMENDATION LEVEL IV



Recommendations for support surfaces must always be individualized, based on individual risk factors, the amount of time spent on the surface, other preventive strategies implemented, function, lifestyle and preferences, and presence or absence of pressure ulcers.⁽¹⁾ It is also important to re-evaluate support surfaces and positioning whenever the person's situation changes. Support surfaces for beds include mattresses and overlays. Overlays and mattresses use similar types of technology to redistribute pressure.⁽²⁴⁾

Research has identified higher interface pressures in seated people with spinal cord injury than in able-bodied or elderly people.⁽¹⁴⁾ This difference is assumed also to exist in recumbent positions, although no evidence supports the assumption. *Research is necessary to determine differences in interface pressure in individuals with spinal cord injury and non-disabled individuals in the recumbent position.* Mawson et al have demonstrated persistent lower blood flow in the skin below the level of injury.⁽³⁴⁾⁽³¹⁾

A Cochrane Review of the literature on support surfaces, which was not specific to the population with spinal cord injury, found higher-specification foam mattresses reduced the incidence of pressure ulcers in high-risk individuals compared with standard hospital foam mattresses.⁽³⁰⁾⁽³²⁾



It is worth noting that, within this review, no consistent definition of higher-specification foam mattresses or standard hospital foam mattresses was provided.

Available data did not distinguish between prevention benefits of different low-pressure reactive surfaces, which included overlays, foam pads, and static air mattresses, and alternating-pressure reactive mattresses.

A prospective crossover comparison of two alternating-air-pressure mattresses in individuals with spinal cord injury compared interface pressure characteristics at the sacrum.⁽⁴⁾ The finding that maximum and average interface pressures and pressure ranges were significantly higher, and minimum interface pressures were significantly lower, on one mattress than the other lacks clinical applicability, as the most clinically relevant interface pressure gradient is undetermined.



An ideal effective bed support surface reduces pressure ulcer risk by providing good pressure redistribution, managing microclimate, and maintaining postural alignment. Surfaces that increase surface area contact through envelopment and accommodate areas of increased pressure can increase the risk of gradual postural deterioration. Determining the optimal bed support surface for an individual generally involves a compromise between pressure management and posture management.

Reassessment



5.16: Reassessment of support surfaces

Re-evaluate the suitability of the support surface for pressure ulcer prevention and treatment at least every 4 years, and sooner if the person's medical condition changes.

RECOMMENDATION LEVEL IV

CONSIDERATIONS

Force and microclimate characteristics

5.17: Microclimate management

Select smooth, low-friction, breathable fabrics for bedding and clothing to optimize microclimate control and minimize friction.

RECOMMENDATION LEVEL IV

Different types of active and reactive support surfaces may redistribute pressure differently. Selecting a support surface is based on individual tolerance of the specific surface.⁽¹⁾ Adoption of particular support surfaces may depend greatly on heat and breathability of the contact surface or fabric. Considerable immersion or envelopment increases the weight-bearing contact area to redistribute the pressure load, but these features may also increase heat and moisture (sweat) accumulation⁽³³⁾.

Impact on function and safety

It is important to consider the effect of the support surface on function of a person with impaired mobility. Both *envelopment*, the ability of a support surface to conform to body contours, and *immersion*, penetration or sinking into a support surface and the resulting instability of the active support surface, can affect the ability to turn or move in bed.

When used with standard beds, overlays with specific pressure-redistributing characteristics improve pressure redistribution and may also improve microclimate control. However, these overlays can raise the height of the mattress to the point where the person is at or higher than the bed rail. The increase of bed height can also affect transitional movements and transfers, which can significantly affect the independence of an individual with mobility limitations. These pressure redistribution surfaces can also affect the ability of healthcare providers to deliver care and reposition patients.

CONCLUSIONS

Positioning for recumbency and recumbent support surfaces play an important role in pressure redistribution, posture management, and microclimate control in people with spinal cord injury across the continuum of care.

Positioning is an important component of pressure ulcer prevention and treatment, and pressure management practices are individually designed and modified as required, based on their effectiveness in pressure ulcer prevention, an individual's ability to incorporate the practices into daily life, and any changes in overall health status over time.

It is important to remember, however, that these advanced pressure-redistribution systems are designed to complement — not replace — frequent repositioning and regular skin checks in pressure ulcer prevention and treatment. Regular assessment in the home can help ensure recumbent support surfaces are functioning properly and remain appropriate for the individual.



REFERENCES

1. Consortium for Spinal Cord Medicine Clinical Practice Guidelines. Pressure ulcer prevention and treatment following spinal cord injury: a clinical practice guideline for health-care professionals. *J Spinal Cord Med* 2001;24(Suppl 1):S40–101.
2. Campbell KE, Woodbury MG, Houghton PE. Implementation of best practice in the prevention of heel pressure ulcers in the acute orthopedic population. *Int Wound J* 2010;7:28–40.
3. Registered Nurses' Association of Ontario. Nursing best practice guideline: Assessment & Management of Stage I to IV Pressure Ulcers 2011. Available at <http://www.rnao.org/bestpractices>. Accessed June 5, 2011.
4. European Pressure Ulcer Advisory Panel and National Pressure Ulcer Advisory Panel. Treatment of pressure ulcers: quick reference guide. Washington, DC: National Pressure Ulcer Advisory Panel; 2009. Available at <http://www.epuap.org>. Accessed June 5, 2011.
5. Royal College of Nursing. Clinical practice guideline. The use of pressure-relieving devices (beds, mattresses and overlays) for the prevention of pressure ulcers in primary and secondary care. Royal College of Nursing. Available at http://www.rcn.org.uk/_data/assets/pdf_file/0007/109843/002444.pdf. Accessed June 25, 2011.
6. Mulder GD, LaPan M. Decubitus ulcers: update on new approaches to treatment. *Geriatrics* 1988;43:37–50.
7. Goetz LL, Brown GS, Priebe MM. Interface pressure characteristics of alternating air cell mattresses in persons with spinal cord injury. *J Spinal Cord Med* 2002;25:167–73.
8. Jesurum J, Joseph K, Davis JM, Suki R. Balloons, beds, and breakdown. Effects of low air loss therapy on the development of pressure ulcers in cardiovascular surgical patients with intra-aortic balloon pump support. *Crit Care Nurs Clin North Am* 1996;8:423–40.
9. Nicosia G, Gliatta A, Woodbury MG, Houghton PE. The effect of pressure-relieving surfaces on the prevention of heel ulcers in a variety of settings: a meta-analysis. *Int Wound J* 2007;4:197–207.
10. Buss IC, Halfens RJG, Abu-Saad HH. The effective time interval for repositioning subjects at risk of pressure sore development. *Rehab Nursing* 2002;27:59–66.
11. Dunn R, Stander J. Pressure sores in spinal cord injury: Active intervention saves costs. *SAJCC* 2008;24:8–12.
12. Hagsisawa S, Ferguson-Pell M. Evidence supporting the use of two-hourly turning for pressure ulcer prevention. *J Tissue Viability* 2008;17:76–81.
13. Sprigle S, Sonenblum S. Assessing evidence supporting redistribution of pressure for pressure ulcer prevention: a review. *J Rehabil Res Dev* 2011;48:203–14.
14. Sae-Sia W, Wipke-Tevis DD, Williams DA. The effect of clinically relevant pressure duration on sacral skin blood flow and temperature in patients after acute spinal cord injury. *Arch Phys Med Rehabil* 2007;88:1673–80.
15. Ontario Health Technology Advisory Committee. OHTAC recommendation. Prevention and management of pressure ulcers. October 2009. http://www.health.gov.on.ca/english/providers/program/ohatc/tech/recommend/rec_pup_20091020.pdf. Accessed June 24, 2011.
16. Ahn H, Singh J, Nathens A, MacDonald RD, Travers A, Tallon J, et al. Pre-hospital care management of a potential spinal cord injured patient: a systematic review of the literature and evidence-based guidelines. *J Neurotrauma* 2011;28:1341–61.
17. National Spinal Cord Injury Statistical Center (NSCISC). Annual report for the model spinal cord injury care systems. Birmingham, AL: NSCISC; 2005. Model Spinal Cord Injury Care Systems.
18. Yarkony GM, Heinemann MW. Pressure ulcers. In: Stover SL, DeLisa JA, Whiteneck GG, eds. *Spinal Cord Injury: Clinical Outcomes from the Model Systems*. Gaithersburg, MD: Aspen Publishing; 1995.
19. Jaglal SB, Munce SEP, Guilcher SH, Couris CM, Fung K, Craven BC, Verrier M. Health system factors associated with rehospitalizations after traumatic spinal cord injury: a population-based study. *Spinal Cord* 2009;47:604–9.
20. Dover H, Pickard W, Swain I, Grundy D. The effectiveness of a pressure clinic in preventing pressure sores. *Paraplegia* 1992;30:267–72.
21. Kennedy P, Berry C, Coggrave M, Rose L, Hamilton L. The effect of a specialist seating assessment clinic on the management of individuals with spinal cord injury. *J Tissue Viability* 2003;13:122–5.
22. Norton L, Sibbald RG. Is bed rest an effective treatment modality for pressure ulcers? *Ostomy Wound Manage* 2004;50:40–53.
23. Norton L, Coutts C, Sibbald RG. Beds: practical pressure management for surfaces/mattresses. *Adv Skin Wound Care* 2011;24:324–32.
24. Connolly SJ, Miller WC, Trenholm K, Titus L, Moir S, Coulson S, et al. Wheeled mobility and seating equipment for the spinal cord injured individual. In: Eng JJ, Teasell RW, Miller WC, Wolfe DL, Townson AF, Hsieh JTC, et al, eds. *Spinal Cord Injury Rehabilitation Evidence*, 2010. Version 3.0.

25. National Pressure Ulcer Advisory Panel Support Surfaces Initiative. Terms and definitions related to support surfaces. Version 01/29/2007. Available at http://www.npuap.org/NPUAP_S3I_TD.pdf. Accessed December 1, 2010.
26. Mistiaen PJ, Jolley DJ, McGowan S, Hickey MB, Spreeuwenberg P, Francke AL. A multilevel analysis of three randomised controlled trials of the Australian Medical Sheepskin in the prevention of sacral pressure ulcers. *Med J Aust* 2010;193:638–41.
27. Mistiaen P, Achterberg W, Ament A, Halfens R, Huizinga J, Montgomery K, et al. The effectiveness of the Australian medical sheepskin for the prevention of pressure ulcers in somatic nursing home patients: a prospective multicenter randomized-controlled trial (ISRCTN17553857). *Wound Repair Regen* 2010;18:572–9.
28. Jolley DJ, Wright R, McGowan S, Hickey MB, Campbell DA, Sinclair RD, Montgomery KC. Preventing pressure ulcers with the Australian Medical Sheepskin: an open-label randomised controlled trial. *Med J Aust* 2004;180:324–7.
29. McGowan S, Montgomery K, Jolley D, Wright R. The role of sheepskins in preventing pressure ulcers in elderly orthopaedic patients. *Prim Intent* 2000;November:127–34.
30. McInnes E, Cullum NA, Bell-Syer SEM, Dumville JC, Jammali-Blasi A. Support surfaces for pressure ulcer prevention. *Cochrane Database of Syst Rev* 2008, Issue 4. Art. No.: CD001735. DOI: 10.1002/14651858.CD001735.pub3.
31. Pase MN. Pressure relief devices, risk factors, and development of pressure ulcers in elderly patients with limited mobility. *Adv Wound Care* 1994;7:38–42.
32. Sibbald R, Goodman L, Woo K, Krasner D, Smart H, Tariq G, et al. Special considerations in wound bed preparation 2011: an update. In: Krasner D, Rodeheaver G, Sibbald, Woo KY, eds. *Chronic Wound Care 5: A Clinical Source Book for Healthcare Professionals*. Malvern, PA: HMP Communications; 2011.
33. International review. Pressure ulcer prevention: pressure, shear, friction and microclimate in context. A consensus document. London: Wounds International; 2010.

CONTENTS

SITTING SUPPORT SURFACES INCLUDING WHEELCHAIRS	109
PRINCIPLES IN ASSESSMENT AND INTERVENTION	109
Neutral pelvic position	109
Sitting posture changes due to spinal cord injury	109
Pelvic and trunk asymmetry	110
Postural instability	110
Spinal deviations	110
Spasticity	111
Microclimate	111
Additional layers	111
Clothing and shoes	112
Sitting posture and positioning principles	112
Evidence	112
Principles of support surface and equipment trial and prescription	113
SITTING ASSESSMENT	114
Goals of sitting assessment or reassessment	114
Specialized seating clinics	115
Components of a comprehensive sitting assessment	115
SITTING INTERVENTION	116
Steps in selecting an appropriate seating support surface	116
1. Seating goals	116
2. Seating simulation and trial	116
4. Follow-up	117
WHEELCHAIR PRESCRIPTION	117
Impact of lifestyle and wheelchair use on wheelchair prescription	118
Wheelchair back supports	119
Wheelchair cushions	119
Evidence	121
Dynamic weight-shifting technology for pressure redistribution	122

OTHER SEATING	124
Bathroom surfaces	124
Commode/toilet	124
Shower bench	125
Travel surfaces	126
Road travel	126
Air travel	126
Other activities and recreation	126
REASSESSMENT OF SEATING SYSTEMS	127
CONCLUSIONS	128
REFERENCES	128

Sitting support surfaces including wheelchairs

PRINCIPLES IN ASSESSMENT AND INTERVENTION

6.1: Comprehensive seating assessment

Provide sitting support surfaces, such as wheelchairs and seating systems, based on the results of the comprehensive specialized interprofessional team assessment, according to individualized anthropometric, ergonomic, musculoskeletal, and functional principles and the individual's personal choices, lifestyle, and living environments.

RECOMMENDATION LEVEL IV

Issues relating to the magnitude of pressure are typically managed by selecting appropriate support surfaces and posture on these surfaces, whereas issues relating to the duration of pressure loading are managed by the frequency of pressure-redistributing movements and use of dynamic surfaces that actively redistribute pressure.⁽¹⁾ It is necessary to address both magnitude and duration of pressure for optimal management of pressure.

Neutral pelvic position

The neutral pelvic position is optimal for pressure management. In this position, the ischial tuberosities are perpendicular to the seat surface, evenly redistributing pressure, and the coccyx is not usually in contact with the seat surface. People with spinal cord injury, however, may have insufficient balance to maintain a neutral pelvic position.

During the physical assessment, moving the person from a supported neutral pelvic tilt into posterior tilt can identify the point at which adequate balance is present. It is important to support the sacrum or posterior superior iliac spine to achieve the optimal amount of pelvic tilt for balance.

If adequate balance is not present, the pelvis slides into posterior tilt to gain balance, increasing friction and shear at the ischial tuberosities and potentially increasing pressure at the coccyx. With excessive posterior tilt, the trunk also flexes forward, affecting pressure distribution, comfort, and function. Decreased muscular control allows the unsupported pelvis to drift into increasing amounts of posterior pelvic tilt, producing more pressure, friction, shear, postural deformities, and discomfort.



The degree of support the equipment provides and the time the person will be sitting on the surface are critical considerations for all sitting support surfaces.

Sitting posture changes due to spinal cord injury

Before prescribing a wheelchair or other seating surface for a person with spinal cord injury, it is critical to perform an individualized assessment of spinal and pelvic positioning to understand the postural requirements of the seating support surfaces. Prolonged sitting promotes the development of abnormal posture and spinal deformities, including kyphosis and scoliosis (**FIGURE 1**).⁽²⁾ In comparison with able-bodied individuals, adult males with spinal cord injury have higher maximum sitting pressures at the body-seat interface, which is distributed over a smaller contact area with more asymmetric pressure loading.⁽³⁾



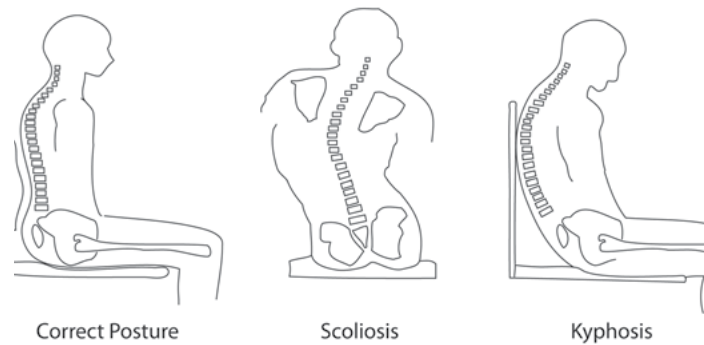



Figure 1. Correct posture and postural changes seen in people with spinal cord injury

Numerous musculoskeletal abnormalities that result in postural instability can exist in people with spinal cord injury.⁽⁴⁾ These include muscle atrophy, unequal muscle tone, and bony deformities. In addition, spinal cord injury is associated with the risk of postural deterioration over time. Postural deterioration may result from spasticity and contractures in people with upper motor neuron lesions and from flaccid paralysis, influenced by gravity, in people with lower motor neuron lesions.  **APPENDIX 1** includes a summary of the impact of spinal cord injury on the body.

PELVIC AND TRUNK ASYMMETRY

Asymmetric sitting posture produces uneven pressure redistribution, with higher pressure on one side.⁽³⁾ The pelvis may be tilted to one side, usually referred to as obliquity, or the pelvis may be level, with the trunk weight shifted to one side. Asymmetry increases weight bearing and pressure at the ischial tuberosity and potentially the greater trochanter on the more heavily loaded side. Trunk asymmetries and/or scoliosis can also increase pressure at any contact point along the trunk or head of the loaded side, depending on the extent of asymmetry. Asymmetries, whether trunk or pelvic, often produce lateral movement of the pelvis across the seating surface over time, due to the effects of gravity and the person's weight no longer being centred over the pelvic base of support. Lateral movement in the direction opposite to the asymmetry may cause friction and shear, especially at the bony prominences, and promote further postural deterioration. Postural support can promote stability and symmetry at rest and decrease gravity-induced postural changes.

POSTURAL INSTABILITY

Trunk positioning centred over the pelvis maintains both anterior–posterior and lateral postural stability. Postural instability, which is a common problem in spinal cord injury, produces a feeling of loss of balance or actual loss of balance, with falling forward or to the side when sitting. Instability decreases control of movement, reducing reach and other functional tasks.⁽⁵⁻⁷⁾

Decreased control of movement during transfers or sitting or when trying to prevent falling may cause friction and shear at the buttocks and back as the body slides across the seating surface in an attempt to gain stability. Reduced trunk and pelvic muscle function and strength in people with spinal cord injury contribute to postural instability. The degree of instability depends on the level of injury and residual muscle innervation. Postural instability also contributes to asymmetry.

SPINAL DEVIATIONS

Postural instability contributes to the typical C-shaped trunk posture seen in people with spinal cord injury. This posture increases balance and stability, and improves function through increased posterior pelvic tilt, which lengthens the base of support and shifts the body's centre of gravity posteriorly. However, posterior pelvic tilt increases pressure on the coccyx and sacrum, contributes to low back pain, and flexes the trunk, promoting abnormal posture and development of spinal deformities, including kyphosis (**FIGURE 1**).⁽⁴⁾

Kyphosis increases the prominence of the spinous processes and reduces the area of the back in contact with the seat back. This change concentrates pressure on a smaller area of the back, usually on the spinous processes at the apex of the curve. A decreased contact area contributes to lateral instability, which may increase trunk asymmetries, including scoliosis; increased risk of friction and shear; and increased risk of pressure ulcers.

SPASTICITY

Spasticity influences postural stability and function and can increase the risk of pressure ulcers. Approximately half of people with spinal cord injury develop spasticity.⁽⁷⁾ Management of spasticity using tone-inhibiting postures can minimize shear and enhance postural stability and function.

The effort of propelling a manual wheelchair can trigger spasms, as can jarring during a transfer onto the commode, or travelling across rough surfaces with manual or power wheelchairs. Spasms can produce rapid, uncontrolled sliding, which can cause friction or shear damage to body areas in contact with the seating surface, especially the buttocks, back, and feet. Sudden and forceful contact with the seating surface during or following a spasm can cause injury, including deep tissue injury.

Tone-inhibiting positioning, including flexing the hips and knees and dorsiflexing the ankles, can reduce the risk of injury from spasms. It may, however, contribute to joint contractures and shortening of the hamstrings and hip extensors, which may negatively influence other aspects of pressure management, such as positioning in bed or transferring into the wheelchair. Implementing a stretching routine and therapeutic positioning in bed reduces this negative influence.

Microclimate

Increased skin temperature may compound the effects of pressure in increasing pressure ulcer risk, but *additional research is required on the impact of increased skin temperature on pressure ulcer risk.*⁽⁸⁾ Increased skin moisture is also a risk factor for pressure ulcer development.

The materials constituting both the cushion and the cover and their ability to wick away moisture affect the amount of heat and moisture at the user–cushion interface. A cushion material that creates greater envelopment and increases contact area, such as foam, can increase heat and moisture. In addition, moisture damages foam. Moisture barriers, such as incontinence covers, increase heat, whereas a spacer mesh increases air circulation. Bladder and bowel management routines may also affect the amount of moisture at the user–support surface interface.

No spinal cord-injury-specific research is available measuring the temperature between the cushion and the buttocks; additional research is necessary to assess the microclimate management abilities of different cushion and cover materials and their impact on pressure ulcer risk.

Cushion cover and clothing materials also affect shear and friction, both by the nature of the fabric (rough or smooth) and by their effect on increasing skin moisture, which increases friction.⁽⁸⁾ *Additional research is needed to better characterize the impact of different materials on friction and shear.*

ADDITIONAL LAYERS

Minimal interference between the support surface and the person using it maximizes the effectiveness of a support surface in redistributing pressure. Additional layers, such as incontinence pads, lambskin, blankets, and pillows can all reduce the immersion or envelopment capabilities of the support surface, reducing the pressure-redistributing properties of the support surface.



The thicker the interference, the greater the reduction in effectiveness of the support surface.



CLOTHING AND SHOES

The person's clothing choice is also important, especially breathability of the fabric and features such as thick seams, buttons, zippers, and pockets that can increase pressure on a specific area and cause skin trauma. A consensus panel developed a guideline in Australia that identified practical considerations for clients with spinal cord injury.⁽⁹⁾ People with spinal cord injury should avoid tight clothing, including underwear; remove back pockets; and avoid filling pockets with items such as keys and mobile phones. An increased frequency of skin checks is recommended when new clothes are worn.



According to the Australian guideline, it is important for people with spinal cord injury to increase their pre-injury shoe size by at least a size to compensate for the development of peripheral edema and prevent pressure ulcers on the feet.⁽⁹⁾

When purchasing footwear, shoes with a firm sole are recommended to assist proper foot positioning and protect the feet from trauma. Ensure the shoe is fitted correctly, and remove excess heel padding. When putting on shoes, it is important for the person always to check for any objects in the shoe and ensure toes are not curled under. It is also important to check feet for signs of pressure every 30 minutes when wearing new shoes.

Sitting posture and positioning principles



6.2: Principles of sitting posture and positioning for pressure management

	RECOMMENDATION LEVEL
<ul style="list-style-type: none"> ■ Address pelvic asymmetry, postural instability, kyphosis and spasticity, using postural management and support surfaces. 	III
<ul style="list-style-type: none"> ■ Evaluate the effects of posture, deformity, and movement on interface pressure distribution and the influence of subdermal tissue loads on sitting support surfaces. 	III
<ul style="list-style-type: none"> ■ Consider the effects of clothing, shoes, and additional layers on the surface's microclimate and pressure- redistributing properties. 	IV

RECOMMENDATION LEVEL III-IV

EVIDENCE

Maintenance of posture over time is important to keep the weight-bearing footprint of the seated individual consistent and to minimize peak pressures over bony areas. Wheelchair positioning can be an important intervention for maintaining or improving sitting ability and preventing pressure ulcers.⁽¹⁰⁾

Both wheelchair cushions and back supports can help ensure the appropriate postural relation between the pelvis and the spine to avoid postural deterioration, thereby improving pressure management.

Karatas et al evaluated dynamic sitting stability and its relation to pressure ulcers in 16 people with spinal cord injury and 18 healthy individuals, using measurements of centre-of-pressure displacement during maximum unsupported trunk leaning forward, backward, to the left, and to the right.⁽⁷⁾ The study found smaller centre-of-pressure displacements in all directions in the spinal cord injury population than in healthy individuals and smaller displacements in forward and backward directions for the seven people with a history of pressure ulcers than for those without a pressure ulcer history. Reduced dynamic postural movement, as demonstrated through centre-of-pressure displacement, may be associated with pressure ulcer development.

Sprigle et al evaluated three clinical measures of reach — functional reach, reach area, and bilateral reach — and several activities of daily living to determine whether compensated and uncompensated measures of reach could be used as postural stability tests.⁽⁶⁾ The level of spinal cord injury significantly predicted the ability to perform the activities

of daily living, as reduced trunk control and the need for lateral support restrict trunk mobility. All compensated and uncompensated measures were correlated with the ability to perform activities of daily living, and uncompensated bilateral reach was most strongly correlated with this ability. These reach measures have clinical utility, and bilateral reach tasks, especially, can assist the clinician in evaluating seated stability and functional movement.

Principles of support surface and equipment trial and prescription

6.3: Sitting support surfaces

Consider the characteristics and adjustability of the support surface to meet postural, functional, comfort, and pressure management needs.

RECOMMENDATION LEVEL IV

6.4: Trial equipment

Recommend support surfaces and equipment based on observations and client and caregiver feedback during the sitting simulation and trial.

Implement a trial of at least 24 hours and preferably several days to ensure the equipment both addresses pressure and microclimate issues and meets functional and lifestyle needs.

RECOMMENDATION LEVEL IV

When recommending sitting support surfaces, it is important to consider the following posture and positioning needs in conjunction with the support surface:

- Maximize buttock and thigh surface contact with each sitting surface to reduce pressure.
- Position the trunk over the pelvis to maintain anterior–posterior and lateral stability.
- Support the spinal curve and pelvis in a neutral, when possible, or toward a neutral position to reduce the risk of postural deterioration and minimize the influence of forces over bony prominences.
- Manage spasticity using tone-inhibiting postures to minimize shear and enhance postural stability and function.
- Correct postural asymmetries using the support of the seating surface. Where correction is not possible, implement accommodations to minimize the risk of postural deterioration and the influence of forces over bony prominences.
- Address postural instability for each seating surface, which may vary across the different sitting surfaces used in the activities of daily living.
- Optimize pressure management for each surface, considering duration of use and pressure management characteristics of the surface.

It is important to address all body areas that experience pressure in the sitting position (**FIGURE 2**).

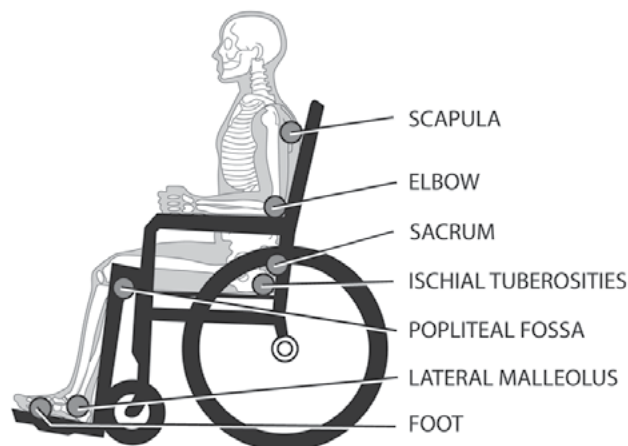

Figure 2. Areas vulnerable to pressure damage in sitting position

Research investigating the postural implications of wheelchairs and seating and their impact on functional tasks highlights the need for individualized attention to spinal and pelvic posture for people with spinal cord injury.⁽¹¹⁾ Research has also identified higher interface pressures in seated people with spinal cord injury than in seated able-bodied and elderly people.



The interface pressure threshold for pressure ulcer development has not been accurately or reliably identified, due both to individual differences and to the contribution of other factors, such as microclimate, friction, and shear.⁽¹¹⁾

Several factors, however, are known to increase risk:

- High peak pressure over bony prominences
- Small interface contact area, decreasing pressure redistribution capabilities
- Asymmetric or uneven weight bearing over the pelvis, increasing exposure of bony prominences to pressure
- Duration, which is potentially more important than amount of pressure

Several studies indicate that people with spinal cord injury are more susceptible to sitting-acquired pressure ulcers, due to higher interface pressures and subdermal tissue strains and stresses around the ischial tuberosities.⁽¹²⁻¹⁶⁾ Typical high-pressure areas are the ischial tuberosities, coccyx, and sacrum.⁽¹¹⁾

SITTING ASSESSMENT

 **CHAPTER 4, *Principles of pressure management, provides further description of the 24-hour approach to pressure management.***

Almost half of pressure ulcers occur as a result of pressure in the sitting position.⁽¹⁷⁾ As a result, the sitting assessment is an essential part of comprehensive 24-hour pressure management. Most commonly, the sitting assessment results provide information to meet the person's wheelchair seating needs. These results also provide the information to meet the needs of the person with spinal cord injury for any other seating surface used. The sitting assessment requires the advanced skills of the occupational therapy and physiotherapy members of the interprofessional team.^(11,18) These individuals need to have combined expertise in assessment and intervention for specialized wheelchair seating in spinal cord injury and the ability to integrate all sitting and recumbent positioning and support surface management concepts across the full 24-hour day, either directly or through consultative service delivery.

Furthermore, clinicians working in this specialized clinical area need regular exposure to individuals with spinal cord injury to develop and maintain a high level of competency and to remain connected to resources in the local region and community. Incomplete assessment and improperly prescribed equipment are associated with abandonment of equipment and intervention strategies.⁽¹²⁾ Early assessment in a seating clinic with expert clinicians increases the skin management ability of people with spinal cord injury.⁽¹³⁾



To ensure that the needs of the person continue to be met as aging changes occur, it is important that qualified healthcare professionals reassess seating needs at regular intervals.

Goals of sitting assessment or reassessment

Sitting posture significantly influences pressure management. The major goal of postural support for sitting is to use support surfaces to maintain skeletal alignment, especially pelvic alignment, over time.⁽¹²⁾ Posture that deviates from midline alignment promotes further postural deterioration and asymmetric pressure distribution, both of which increase the risk of skin breakdown. Sitting posture dramatically affects pelvic orientation which, in turn, affects pressure on the

ischial tuberosities, coccyx, sacrum, and possibly the greater trochanters.⁽¹⁹⁾ It is important to gain a full understanding of posture and positioning on the seating surfaces used by the person to determine the influence on skin integrity, whether it is the initial assessment or a reassessment.

Specialized seating clinics

6.5: Specialized seating clinics

When possible, use specialized seating clinics with an interprofessional team of clinicians who have expert training and experience working with people with spinal cord injury to assess and recommend wheelchairs and other sitting support surfaces.

RECOMMENDATION LEVEL IIA

Comprehensive sitting assessment and selection and design of customized seating systems are specialized skills. Seating clinics with skilled professionals have been shown to reduce the incidence of pressure ulcers and readmission rates due to pressure ulcers.⁽¹⁰⁾ Kennedy et al evaluated 50 people with spinal cord injury and demonstrated that attendance at specialized seating clinics significantly increased scores on the skin subscale of the Needs Assessment Checklist (sNAC).⁽²⁰⁾ Based on this research, Spinal Cord Injury Rehabilitation Evidence (SCIRE) concluded that there was level 2 evidence showing that early attendance, within 1 month, at specialized seating assessment clinics increases skin management abilities of individuals after spinal cord injury.⁽¹¹⁾

Components of a comprehensive sitting assessment

Each component of the sitting assessment, which is outlined below, provides essential information to determine the most appropriate sitting surfaces to trial during the intervention phase. The components of the assessment build upon each other, with analysis and assessment occurring simultaneously.

- Baseline postural assessment in current equipment:
 - » Evaluate sitting in the current wheelchair and seating system, and on other seating surfaces as appropriate.
 - » Assess posture and position, based on principles of assessment.
 - » Identify any postural asymmetry or instability, physical limitations, or issues with spasticity.
 - » Evaluate effectiveness of pressure-redistributing movements.
- Assessment in supine position:
 - » Evaluate the person in the supine position, preferably on a firm flat surface. Assess passive range of motion of the pelvis, hips, knees, and ankles in all directions in this gravity-eliminated position, noting the influence of tone, spasticity, skeletal changes or limitations, and contractures.
 - » Inspect the skin, including in a mimicked sitting position.
 - » Assess mobility, including transfers between surfaces and transitional movements from sitting to supine.
 - » Complete body measurements if it is not possible to complete them in the sitting position.
- Assessment in sitting position:
 - » Evaluate sitting on a firm flat surface, such as a plinth.
 - » Assess sitting posture, including the influence of gravity, balance, and upper extremity function. Consider findings from the supine assessment.
 - » Simulate potential supports to correct or accommodate posture.
 - » Assess mobility, including transfers between surfaces and transitional movements.
 - » Complete body measurements.
- Evaluation of the current seating surface without the person in it:
 - » Evaluate the condition of equipment, including removing covers where appropriate.
 - » Identify factors potentially contributing to pressure ulcer risk or an existing pressure ulcer.



SITTING INTERVENTION

Steps in selecting an appropriate seating support surface

Several steps following the comprehensive assessment are required to determine the sitting support surface that best meets individual goals while providing postural support, mobility, and pressure redistribution.⁽¹⁴⁾

1. SEATING GOALS

Each person is unique and may use a wheelchair differently in carrying out activities of daily life. An ideal wheelchair and seating system does not exist; a variety of compromises and trade-offs are made to accommodate lifestyle, function, postural support, comfort, and pressure management. Close collaboration between the person with spinal cord injury and therapist is necessary to achieve the optimal wheelchair and seating prescription. Identification of specific product parameters must be based on the assessment findings to:

- Meet the person's goals and functional needs
- Provide optimal alignment, balance, function, pressure redistribution, and microclimate management
- Reduce the potential for development of deformities and pressure ulcers

Possible funding resources are also identified at this stage.

2. SEATING SIMULATION AND TRIAL

The intervention plan must include an opportunity for trial of the recommendations, in the person's environment whenever possible, to determine an acceptable balance between postural stability, function, optimal pressure redistribution, comfort, and lifestyle. The length of the trial is specific to the individual and related to the person's needs and the availability of equipment from manufacturers and vendors. The person needs to be involved in the process and educated about the implications for function and pressure ulcer risk of specific decisions.

A knowledgeable vendor must be involved at this step. The clinician discusses the product parameters with the vendor and uses them to assemble suitable trial equipment to achieve defined seating goals. Critical to this step is ongoing analysis and integration of assessment results with the findings of the trials or simulations.



When the individual, the clinician, and the vendor are in agreement that the trial approaches the optimal product parameters, the clinician prepares an equipment prescription and initiates funding applications as appropriate.

Equipment trials must evaluate the following parameters to determine the most appropriate equipment for any seating surface:

- **Pressure:**
 - » Weight-bearing contact area
 - » Identification of bony prominences contacting the support surface
 - » Extent and duration of pressure loading on bony prominences
 - » Effectiveness of pressure-offloading and redistributing movements
- **Posture and positioning:**
 - » Effectiveness of spasticity management through tone-inhibiting positioning
 - » Postural alignment: asymmetries, uneven weight bearing over bony prominences, potential for friction and shear
 - » Postural instability: effect on alignment, asymmetries, and weight bearing
- **Sitting support surface:**
 - » Surface characteristics and condition
 - » Impact of surface on microclimate
 - » Comfort when using support surface

- **Function:**
 - » Postural alignment during the activity and ability to return to original alignment when performing functional tasks
 - » Potential for tissue damage during transfers and transitional movements
 - » Influence of fatigue on function, posture, and mobility
- **Caregiver:**
 - » Skill, knowledge, and ability to assist with use of support surfaces and transfers
- **Additional layers:**
 - » Impact on function, pressure, friction, shear, and microclimate when adding padding or supports to a sitting surface
- **Upgrading:**
 - » Impact on function, pressure, friction, shear, and microclimate when upgrading equipment; for example, upgrading to a tilt shower commode may reduce independent function and require more assistance

 **CHAPTER 4, Principles of pressure management, describes other relevant principles and considerations that guide this area of practice.**

3. SUPPORT SURFACE AND EQUIPMENT PRESCRIPTION

The equipment prescription details the specific equipment needed to improve posture and pressure management and meet the person's goals. When the equipment is delivered, the clinician ensures that fit and function are correct and trains the person in positioning and use of the equipment as necessary.

Recommendations for seating support surfaces must always be based on the findings of the comprehensive assessment. Recommendations must be individualized, based on factors such as individual risk and history, the amount of time spent on the surface, posture and positioning on the surface, other preventive strategies implemented, functional tasks on the surface, comfort, lifestyle and preferences, and presence or absence of a pressure ulcer.^(5,11,21)

4. FOLLOW-UP

The clinician arranges follow-up to monitor effectiveness of the recommended support surfaces, to ensure that education about the equipment and pressure management strategies is integrated into the person's daily life, and to verify that short-term seating goals are achieved and progress is made toward long-term goals. Also included in follow-up is planning for regular reassessment.

WHEELCHAIR PRESCRIPTION



6.6: Wheelchair prescription

Provide an individually prescribed wheelchair and pressure-redistributing seating system in collaboration with the person who will be using the equipment. Ensure wheelchair configuration, postural supports, and sitting surfaces facilitate optimal wheelchair positioning and function.

RECOMMENDATION LEVEL IIA

 *For additional information about wheelchairs and other seating systems and some desirable features for people with spinal cord injury, refer to: Connolly SJ, Miller WC, Trenholm K, Titus L, Moir S, Coulson S, Foulon BL, Mehta S, Aubut JL. Wheeled mobility and seating equipment for the spinal cord injured individual. In Eng JJ, Teasell RW, Miller WC, Wolfe DL, Townson AF, Hsieh JTC, Connolly SJ, Mehta S, Sakakibara BM, editors. Spinal Cord Injury Rehabilitation Evidence, 2010. Version 3.0.*

Most sitting surfaces have little flexibility or adjustability to meet an individual's specific needs. The exception is the wheelchair and seating system. Wheelchair frames are both flexible and adjustable, and a broad range of seating products is available. A wheelchair is an integral part of life for a person with spinal cord injury, and people with spinal cord injury may spend 3 to 16 hours a day in the wheelchair. It is necessary for health and well-being and for function and participation in life.⁽²²⁾ It is therefore essential to fit the components of the wheelchair and seating system specifically to the individual for pressure management, function, and comfort.^(9,11)

The ability of seating support surfaces within the wheelchair to provide adequate stability to maintain postural alignment and support the individual against gravity can reduce the risk of postural deterioration over time, improving pressure management. Postural management is critical to proper seating, as sitting posture affects ischial pressure and overall pressure distribution.

Appropriate wheelchair prescription and service delivery relies on direct interaction of several stakeholders.



Most experts stress the importance of people with spinal cord injury who require a wheelchair, playing a central role throughout the wheelchair service delivery process.⁽²³⁾

Clinicians involved in prescribing the wheelchair and wheelchair suppliers all play an important role.



Little evidence is available to guide wheelchair and seating equipment prescription for pressure management.⁽²¹⁾ The general lack of good scientific evidence presents a clinical challenge that further complicates an already multifaceted process for making prescribing decisions about wheelchairs and other seating equipment.⁽¹¹⁾ A wheelchair prescription and seating system must both accommodate existing problems, such as spinal deformity or abnormal tone, and prevent complications, including pressure ulcers, postural deformities, and arm and back pain from wheelchair propulsion.

Impact of lifestyle and wheelchair use on wheelchair prescription

Prescribing decisions can be complicated by the way a wheelchair is used. A study of 20 individuals with spinal cord injury assessed how they perceived the relation between their wheelchairs and pressure ulcer development.⁽²⁴⁾ Participants were recruited from a pressure ulcer management unit and most had had at least one pressure ulcer repaired surgically. This wheelchair assessment study included participant interviews and remote monitoring of wheelchair occupancy by cushion sensors to collect data over a week. Data analysis found wheelchair-related factors exacerbating risk included the following:

- Wheelchair selection:
 - » Poor selection rationale: focus on aesthetics, not seating needs
 - » Inadequate communication: not informing the clinician that a chair felt right or wrong
 - » Time necessary to adapt to a new wheelchair
- Wheelchair integration into lifestyle:
 - » Wheelchair modifications affecting seating dynamics: making custom cushions
 - » Wheelchair use for purposes other than recommended ones: use as a bed, a vehicle, or a living space. Back rests are not designed to provide prolonged pressure redistribution in reclined or fully tilted positions. Long journeys mean excessive time in the wheelchair, but some individuals may not have a car or money for the bus.
 - » Conflict between caring for health and participating fully in life, most often by increasing the amount of time the wheelchair is used to accomplish household tasks, achieve career goals, or participate in social events.
- Wheelchair malfunction may pose a pressure ulcer risk; chairs may not be repaired or maintained properly.
- Unplanned situations, such as being stranded at the airport or being homeless, affect risk.

Analysis of individual stories revealed that, because of the length of time participants used their wheelchairs, the chairs tended to become an extension of the person and more a living space than transportation.⁽²⁴⁾ Incorporating the individual's perspective on wheelchair use into a sitting assessment and intervention illuminates the individual's pressure ulcer risk and provide a basis for education about safe wheelchair use and maintenance.  **CHAPTER 2, Human factors affecting pressure ulcer prevention, discusses strategies for improving patient adoption of pressure management strategies.**

Wheelchair back supports

6.7: Back support selection

Select the back support in conjunction with the cushion. Choose a back support for trunk alignment and pelvic control to manage pressure, considering its impact on functional tasks and mobility of the trunk, shoulder girdle, and arms.

RECOMMENDATION LEVEL IV

6.8: Back support angle

If the person tends toward a posterior pelvic tilt sitting posture, angle the back support to:

- Support the posterior superior iliac spine or sacrum to increase pelvic stability and prevent gradual drift into more posterior pelvic tilt, which increases pressure on the coccyx and causes friction and shear
- Accommodate hip flexion limitations if the hip cannot be flexed to 90° to prevent the pelvis from sliding forward
- Accommodate hamstring tightness if not achieved through foot positioning
- Support the trunk over the pelvic base of support and strive for even pressure distribution across both buttocks

RECOMMENDATION LEVEL IV

An individually prescribed back support can reduce pelvic shearing forces and stabilize and support the trunk in alignment to minimize asymmetrical weight bearing.



It is important to consider the back support in combination with the cushion, as both influence pelvic positioning. Back rests can contribute to pressure redistribution by increasing contact area and weight-bearing surface.

Back and lateral supports must allow the pelvis to be positioned against the back support. A narrow back support or lateral supports may prevent the trunk and pelvis from fitting comfortably into the space. Improperly sized supports can lead to a posterior pelvic tilt or rotation of the trunk and pelvis, which can increase friction, shear, and pressure on the coccyx and contribute to postural asymmetries and uneven pressure distribution.

Wheelchair cushions

Numerous commercially available wheelchair cushions provide pressure redistribution using the principles of immersion and/or envelopment. A few custom wheelchair cushions provide true offloading of the bony areas of the pelvis during sitting, using the principle of force isolation. The role of the cushion is to support the pelvis for postural control, pressure management, and comfort, while facilitating function.



6.9: Wheelchair cushions

Consider a variety of factors for comprehensive pressure management when selecting a wheelchair cushion:

- Influence of cushion characteristics, including weight, on wheelchair performance
- Pressure-redistributing or offloading characteristics at bony areas
- Positioning capabilities for postural management in resting and dynamic positions
- Maintenance of a supported and symmetrical resting posture to prevent postural deterioration over time
- Adequate stability for function and prevention of long-term postural deterioration
- Microclimate management
- Shear and friction reduction at the user-cushion interface
- Comfort

RECOMMENDATION LEVEL III

Determining the most appropriate wheelchair cushion for an individual with spinal cord injury includes evaluating the following cushion attributes:

- Pressure redistribution properties
- Microclimate management attributes
- Effect on postural support and stability
- Impact on function
- Overall postural management, in conjunction with the back support and configuration of the wheelchair frame
- Effect on comfort

Pressure mapping may assist the clinician in identifying the interface pressure-redistributing ability of a cushion and asymmetries in pressure distribution due to posture. Together with observations of stability, function, and microclimate, these factors help individualize cushion selection.⁽²¹⁾



6.10: Cushion maintenance

Teach the individual with spinal cord injury and the caregiver to:

- Care for and maintain the wheelchair cushion
- Monitor the cushion for signs of wear at an appropriate frequency
- Set up the cushion properly, including orientation and monitoring for bottoming out
- Replace the cushion if it is deteriorating
- Avoid placing additional layers on top of the cushion unless deemed essential

RECOMMENDATION LEVEL IV

Aging changes affecting the skin can increase susceptibility to pressure ulcer development, and routine reassessment can ensure that cushion choice remains appropriate. Ongoing monitoring of cushions by the individual with spinal cord injury is necessary to ensure continued effective pressure management capabilities and adequate postural support. It is important to inspect and maintain wheelchair support surfaces regularly. Owners manuals provide specific instructions about cleaning and maintenance.^(25,26) Be sure to check for bottoming out of the cushion where bony prominences protrude through the cushion and directly contact the wheelchair seating surface (see **FIGURE 3**). Place therapist's hand with palm up between the person and the cushion. .

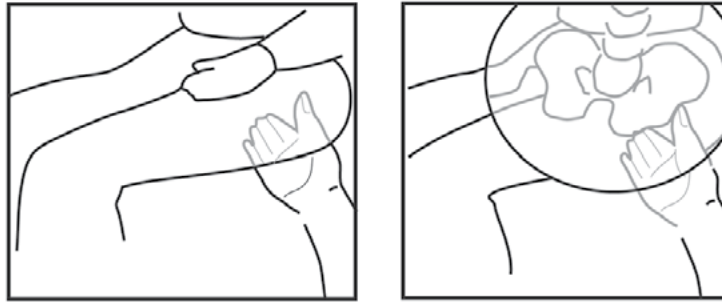

Figure 3. Checking for bottoming out in sitting position. Note location of hand under the ischial tuberosity.

Cushions should be replaced based on the manufacturer's lifespan data, or sooner if the support surface deteriorates, is no longer suitable, or pressure problems develop.⁽⁶⁵⁾ Cushions that have lost their pressure-redistributing characteristics can quickly cause pressure ulcers.

EVIDENCE

Research that has evaluated cushion performance is inconclusive as to which type of cushion provides the best pressure management. Cushion selection should be based on the individual's combined needs for pressure management, postural support, comfort, function, and lifestyle to maximize effectiveness and reduce the potential for abandonment.



Research has not evaluated the performance characteristics of all cushion types.

Little evidence demonstrates that any particular type of cushion decreases pressure ulcer development.⁽²¹⁾

Research is needed to determine whether decreasing pressure at the ischial tuberosities or improving microclimate management helps prevent pressure ulcers.

👁 *For additional information about wheelchair cushions, refer to: Connolly SJ, Miller WC, Trenholm K, Titus L, Moir S, Coulson S, Foulon BL, Mehta S, Aubut JL. Wheeled mobility and seating equipment for the spinal cord injured individual. In Eng JJ, Teasell RW, Miller WC, Wolfe DL, Townson AF, Hsieh JTC, Connolly SJ, Mehta S, Sakakibara BM, editors. Spinal Cord Injury Rehabilitation Evidence, 2010. Version 3.0.*

This review concluded that "contoured foam cushions compared to flat foam cushions seem to provide a seat interface that reduces the damaging effects of external loading and tissue damage."⁽¹¹⁾ Contoured cushions tend to redistribute pressure well, based on the principle of envelopment increasing contact area. Li et al used computer-assisted design and force sensor array data to develop custom-contoured cushions to prevent pressure ulcers in 16 people with spinal cord injury and 12 healthy individuals, none of whom had experienced a pressure ulcer within the past year.⁽²⁷⁾ Study participants felt the custom cushion improved comfort and both lateral and anteroposterior stability. The cushion redistributed pressure under the buttocks, reducing the pressure gradient and peak and mean pressures, and improved balance, according to participant reports. The study did not, however, collect information about the use of the custom cushion and pressure ulcer incidence.

Ferrarin et al performed a comparative biomechanical evaluation of four cushions in three different populations.⁽²⁸⁾ Selected for evaluation were the following cushion types:

- Gel- and air-filled bubbles on a foam base
- Gel-filled bubbles on a foam base
- Communicating air-filled rubber cells on a flat rubber base
- Contoured foam base covered with silicone gel pad in the ischial area

Participating populations were people with spinal cord injury, individuals with multiple sclerosis, and motor-impaired elderly individuals. Posture and the location of pressure peaks differed with each cushion, although no significant differences were seen in pressure reduction. The authors also suggested alternating two cushions, each of which promoted a different posture. The study reinforced the importance of individualizing cushion selection for each person and of using mapping results in combination with other assessment techniques.

Linder-Ganz et al assessed the magnitude and distribution of strain and stress in the subdermal tissues under the ischial tuberosities of paraplegic people with spinal cord injury during sitting on flat foam and lying down, and compared the data with results gathered from healthy individuals.⁽¹⁵⁾ Healthy individuals had significantly greater gluteal muscle thickness under the ischial tuberosities than people with paraplegia. Individuals with spinal cord injury had significantly greater ischial tuberosity radius than healthy individuals, suggesting structural changes due to chronic sitting. Internal tissue loads were significantly higher in people with spinal cord injury than in healthy individuals during sitting, and subdermal tissue loads under the ischial tuberosities were significantly reduced when lying down compared with sitting. These findings support the inherently increased susceptibility of individuals with spinal cord injury to deep tissue trauma due to increased interface pressure at bony prominences when using basic support surfaces. They also strengthen the recommendation that individuals with paraplegia lie down periodically after prolonged sitting to reduce the risk of ischial pressure ulcers.

Thorfinn et al investigated the distribution of sitting pressure in the buttock area, the threshold for reactive hyperemia, and any correlations in individuals with spinal cord injury and in healthy subjects.⁽¹²⁾ People with spinal cord injury tend to experience greater interface pressure than healthy individuals, possibly at least partially due to muscle atrophy and low muscle tone. Wheelchair support surfaces therefore need excellent pressure redistribution or offloading properties to reduce the risk of tissue ischemia and ischial pressure ulcers. The weaker hyperemic response in people with spinal cord injury may indicate decreased recovery of tissue perfusion and increased pressure ulcer risk. This finding has implications for interpreting skin check observations.

Dynamic weight-shifting technology for pressure redistribution

Pressure redistribution strategies may be intentional weight-shifting movements performed by the individual or his or her caregiver, or may occur inherently through functional movements as part of daily activities. Dynamic weight shifts using assistive technologies can help people who are unable to perform purposeful or effective active (manual) or functional weight shifts.  **CHAPTER 7, Mobility, activity, and conditioning, provides information and recommendations related to intentional movements used for pressure redistribution including weight shifts. Chapter 4, Principles of pressure management, provides information about pressure redistribution strategies.**

A dynamic weight-shifting system may be appropriate for people with spinal cord injury when active pressure management techniques are ineffective or not possible.⁽¹¹⁾ Dynamic weight-shifting technology used for pressure management includes tilt, recline, elevating leg rests, and standing wheelchairs. These assistive technology options are available in manual and power forms on both manual and power wheelchairs. A power wheelchair with power weight-shift technology may maximize independence in changing positions to manage pressure. However, power is not always feasible or preferred, and the recommended wheelchair and weight-shifting technology must meet individual needs for managing environment, posture, lifestyle, function, comfort, pressure, edema, and bladder emptying.



6.11: Dynamic weight-shifting

Consider power weight-shifting technology when other methods, such as active pressure redistribution or pressure redistribution through functional movements, are not effective or not possible.

RECOMMENDATION LEVEL IV

6.12: Power weight-shifting and pressure management

Encourage use of power weight-shifting technology, such as tilt, recline, and stand, frequently throughout the day to reduce the effects of sitting pressure on bony prominences of the buttocks.

Individualize these strategies for each person using pressure mapping, palpation, and skin response. Start with a position change that can be maintained for 2 minutes, at least once every 15 minutes.

RECOMMENDATION LEVEL IV**6.13: Power tilt**

Add full tilt gradually where possible to increase blood flow over the ischial tuberosities. A minimum of 30° tilt is required to adequately redistribute pressure and increase blood flow.

RECOMMENDATION LEVEL IIA

Recline may offer increased area for pressure redistribution and opportunities for improving comfort, managing tone, and completing functional activities. Recline may, however, increase spinal extensor tone.⁽¹¹⁾ During reclining, increased extensor tone may reduce hip and trunk flexion and the ability to return to the original position, and sliding may occur, causing friction and shear at the buttock and back.



Sonenblum et al measured tilt angles used by 16 full-time users of power wheelchairs, finding that most people tilted back between 15° and 29°, and few subjects tilted more than 45°.⁽¹⁷⁾

However, a minimum of 30° of tilt is required to gain the benefits of pressure reduction and blood flow increase; the greater the amount of tilt, the greater the benefit.^(29,30)



To minimize friction and shear due to sliding resulting from increased extensor tone during reclining, it is important to tilt the chair before reclining or elevating leg rests.

The literature is unclear about the amount of recline needed for adequate reduction of the effects of sitting pressure. Aissaoui et al found a 40.2% reduction in peak pressure at the ischial tuberosities at 120° of recline.⁽³¹⁾ The literature is also unclear about the effects of friction and shear, and therefore these must be carefully considered when recommending use of recline for pressure management. Hobson found a 12% reduction in maximum pressure at the ischial tuberosities at 120° of recline and an 11% reduction in maximum pressure at ischial tuberosities at 25° of tilt.⁽³²⁾ Shear forces, however, increased 7% at 110° of recline and 25% at 120° of recline.

A pilot study (N=12) of the use of powered wheelchair functions in the community over a 2-week period included four individuals with spinal cord injury.⁽¹⁹⁾ Study participants used their wheelchairs for 11.8 ± 3.4 hours per day and spent little time in the fully upright position. All accessed tilt-in-space and recline to change their posture for comfort, and 70% used it to relieve pressure on the buttocks. Recline was also used for napping, self-catheterization, and exercises. On average, study participants repositioned themselves every 53.6 ± 47.0 minutes, and they accessed tilt-in-space 11.9 ± 9.4 times a day, recline 10.0 ± 7.9 times, and seat elevation 4.3 ± 4.5 times. Although subjects repositioned themselves consistently, the frequency was lower than generally recommended by guidelines.

Another study evaluating the use of power tilt systems for 1 to 2 weeks in everyday life in the community included 10 people with spinal cord injury among 16 participants.⁽¹⁷⁾ The study also monitored pressure-redistributing movements. Participants used their wheelchairs for a mean 11.0 hours a day. More than half of the participants spent most of their time at a small (< 15°) tilt, and approximately one-third spent most of their time at a medium (15°–29°) tilt. Most participants

had more than one reason for using tilt systems, such as physiologic reasons, including pressure management, comfort, rest, functional independence, and posture. Participants using the system for pressure-redistributing movements did not perform more frequent pressure-redistributing tilts (from $< 30^\circ$ to $> 30^\circ$ for > 1 minute) than those who were not using the system for pressure redistribution. In neither case did the frequency of these tilts approach guideline recommendations. Some participants reported large tilts were uncomfortable and made them feel unstable. Others overestimated the degree of tilt. In addition, large tilts make social interaction difficult. Furthermore, participants may not have paid adequate attention to performing pressure-relieving movements. It is important to note that no specific magnitude of tilt ensures pressure ulcer prevention.



Providing weight-shifting technology only manages pressure if it is used effectively.

People may not use weight-shifting technology adequately for pressure management benefits, possibly due to misperception of the degree of tilt, lack of attention to the need for regular pressure reliefs, and lack of integration of techniques into daily activities.⁽¹⁹⁾

Other seating

In addition to wheelchairs, people with spinal cord injury use a variety of other seating. It is critical to include other seating equipment in a full sitting assessment to determine their individual suitability.



6.14: Other sitting surfaces

Assess and prescribe options for other seating needs and provide recommendations for transfers and repositioning as part of the seating assessment to ensure that these surfaces and their use do not cause pressure ulcers. These needs may include:

- Bathroom surfaces, such as a commode, toilet, shower bench, or other surface
- Seating options for travel
- Sports wheelchairs and seating for recreational and other activities
- Any other surface the person may use other than the wheelchair

RECOMMENDATION LEVEL IV

Bathroom surfaces

COMMODE/TOILET



6.15: Bowel routine

Consider using a pressure-redistributing surface on the commode or toilet to minimize pressure ulcer risk. Optimize the bowel care routine to minimize time using the commode, and reassess the bowel program if more than 1 hour is required.

Consider a tilt commode if postural instability results in sliding or uneven pressure distribution on the sitting surface. Consider customized surfaces if necessary.

RECOMMENDATION LEVEL IV

Using a commode or the toilet provides a gravitational benefit for bowel care and decreases incontinence, but no commode or toilet has good pressure management characteristics. This is due to the inherently smaller surface area for pressure redistribution. The smaller surface and the donut effect, caused by the small ring-shaped surface, can create a significant risk of pressure ulcer. The hard sitting surface of commodes exacerbates the effect. The risk of skin injury is also increased as bare skin is in contact with the commode surface; friction and shear are significant concerns.

Spasticity and postural asymmetries can also contribute to injury from friction and shear, if pelvic movement produces sliding into the commode. As commodes age, the hard plastic seat can crack, pinching or cutting the skin. A padded protective surface on the commode or toilet may reduce this risk, if the surface does not interfere with transfers or function. A tilt commode may minimize pressure through improvements in postural stability, but it may place the person in a less functional position. It is critical to balance pressure management, function, client preference, and the availability of assistance when selecting a commode. Assessing the suitability of a commode for an individual involves a problem-solving approach:

- What equipment is used for toileting?
- How long does someone sit to complete toileting routine?
- How is the transfer from the wheelchair to the commode managed?
- How stable is the positioning on the toilet or commode?
- Is repositioning possible?
- How does the process affect spasticity?

SHOWER BENCH



Showering is preferred to bathing if a pressure ulcer is present..

Paraplegia is associated with more potential risk factors during showering than tetraplegia, primarily due to the greater number of transfers. Risks during transfers to the edge or bottom of the tub include the potential for falls, impact injuries, friction, shear, and skin tears. Assessing the showering surface and transfers involves examining the following:

- Shower bench or other surface used for showering
- Time required on each surface
- Type of surfaces involved
- Potential for friction and shear with wet skin for each surface
- Number of transfers
- Muscle tone
- Stability
- Function
- Independence

Specific factors to consider are the following:

- Mechanisms to ensure the water temperature is not hazardous to the skin (too hot or cold)
- Hardness of the surface, especially at the ischial tuberosities
- Flatness of the surface, reducing buttock contact area
- Wet and slippery environment, promoting instability and possibly maceration
- Type and quality of transfers for bathing or showering
- Risk of friction, shear, and contact injury during transfers and bathing

Travel surfaces



6.16: Equipment options for travel

Advise the individual with spinal cord injury about equipment options and appropriate preventive strategies during travel.

Educate the person and provide written information to minimize the risk of a pressure ulcer during travel.

RECOMMENDATION LEVEL IV

ROAD TRAVEL

The Australian guideline on practical considerations for pressure ulcer prevention in the spinal cord injury population lists the following strategies for reducing pressure ulcer risk during road travel⁽⁹⁾:

- Ensure transfers are performed safely.
- Reposition every 100 km or hourly, whichever time period is shorter, as the person is able.
- Use prescribed pressure-redistributing support surfaces for travel, and evaluate the impact of the additional surface on postural stability and function.
- Be cognizant of the potential for automobile vibration to affect balance, causing sliding, friction, and shear forces.
- Prevent excessive heat from causing burns: heat sources include hot car surfaces, such as seat belt buckles, and car heaters blowing on the legs.
- Ensure shoes and socks are worn at all times.

AIR TRAVEL

Strategies for reducing pressure ulcer risk during air travel include the following⁽⁹⁾:

- Inform the airline of special needs and determine the availability of a hoist when the flight is booked.
- Request an aisle seat with a removable arm rest to minimize the risk of contact injuries during transfers.
- Empty the bladder or external urinary device before boarding the aircraft to prevent skin maceration from wetness.
- Use travel versions of the prescribed cushion in the airplane seat and transport seat, if one is required for boarding the plane, to maintain pressure redistribution.
- Adjust pressure in air flotation cushions to compensate for air pressure changes during flight.
- Check tightness of shoes and straps from leg bags, as feet and legs may swell.

Other activities and recreation

When a person with spinal cord injury uses surfaces other than the prescribed wheelchair, it is important to consider the implications for postural management and risks associated with the support surfaces, such as the ability to transfer on and off unusual surfaces; time using the surface; postural support, positioning, and stability; ability to perform pressure-redistributing movements; and possibility of adaptation with additional padding or protection during use.

Risk management is important for wheelchair sports; for recreational activities not using the wheelchair, such as snowmobiling, horseback riding, and sailing; and for appointments or investigations requiring transfer out of the wheelchair, such as dentist appointments or imaging studies.

Reassessment of seating systems

People with spinal cord injury need to understand that regular reassessment becomes even more important over time. Many physical changes, including long-term postural changes, aging changes, and new comorbidities, can affect pressure ulcer risk. Regular reassessment ensures the person's equipment, support surfaces, and prevention strategies are updated as necessary to deal with the changing situation.  **CHAPTER 4, Principles of pressure management, provides information about principles relating to reassessment.**

In addition to equipment breakdown and the development of a pressure ulcer, problems alerting the clinician and/or the person with the spinal cord injury to the need for reassessment include any significant functional or medical change that can affect the ability to sit, such as:

- Changes in body weight or spasticity
- Surgery
- Deconditioning
- Postural difficulties
- Pain

6.17: Education about the need for regular reassessment

Educate the individual with spinal cord injury to monitor the condition of seating equipment and support surfaces regularly to ensure the equipment remains effective for pressure management.

RECOMMENDATION LEVEL IV

6.18: Schedule for periodic reassessment

Establish a mechanism for regular reassessment of performance of sitting support surfaces specific to pressure ulcer prevention and treatment. Schedule reassessment at least every 2 years, or sooner if any of the following occur:

- Health status changes, including weight or medical changes
- Changes in functional status
- Equipment wear or disrepair
- Pressure ulcer development
- Changes in living situation

RECOMMENDATION LEVEL IV

6.19: Replacement of pressure management equipment

Replace seating equipment and support surfaces according to manufacturer's recommendations, or sooner if equipment demonstrates any signs of deterioration, including but not limited to wear, cracking, and allowing bottoming out.

RECOMMENDATION LEVEL IV

As healthcare system changes have resulted in shorter rehabilitation stays, it is important periodically to reassess the suitability of the equipment chosen initially.⁽¹¹⁾ Education and reminders about routine maintenance can help ensure that the wheelchair does not contribute to pressure ulcer risk.

Consider use of specialized seating clinics as an effective means of regularly checking seating systems and reviewing the pressure management program. According to SCIRE, "The incorporation of seating clinics into both the inpatient and outpatient rehabilitation program has been shown to reduce the incidence of pressure ulcers and readmission rates due to



pressure ulcers.”⁽²¹⁾ Early assessment in a specialized seating clinic increases the skin management ability of people with spinal cord injury.⁽²¹⁾ Almost half of pressure ulcers occur as a result of pressure in the seated position.⁽²⁷⁾  **CHAPTER 4, *Principles of pressure management, provides information about sitting assessment.***

Proper care and maintenance of seating equipment and support surfaces ensures optimal performance of the equipment for pressure management. It is important to reassess seating equipment, support surfaces, and positioning regularly and whenever relevant changes occur, such as development of an ulcer or other complication. Initially effective equipment, support surfaces, and positioning may no longer be appropriate several years later. Reassessment allows identification of the following:

- Changes in posture or skin tolerance
- Need for additional education
- Need for equipment maintenance and repairs
- Adequacy of functional management with the prescribed system, or advisability of transitioning to a different system to accommodate aging changes or other needs.

CONCLUSIONS

A properly configured wheelchair fitted with an effective seating system can help reduce the risk of a pressure ulcer disrupting the life of a person with spinal cord injury.

Wheelchair support surfaces play a critical role in pressure ulcer prevention, but no wheelchair cushion has been proven to prevent the development of pressure ulcers. Selection of the best cushion for an individual considers a variety of factors in addition to pressure redistribution, including microclimate management, function, and comfort.

Postural management, positioning, and pressure-redistributing movements are central to pressure ulcer prevention. Initial good habits can deteriorate over time; periodic re-education is beneficial. Similarly, changes in equipment, support surfaces, and pressure management strategies may be necessary to accommodate changes in physical status associated with aging and increasing duration of spinal cord injury.

Regular reassessment is necessary to identify changing risk levels and intervene before a pressure ulcer develops.

REFERENCES

1. Sprigle S, Sorenblum S. Assessing evidence supporting redistribution of pressure for pressure ulcer prevention: a review. *J Rehabil Res Dev* 2011;48:203–14.
2. Guihan M, Hastings J, Garber S. Therapists' role in pressure ulcer management in persons with spinal cord injury. *J Spinal Cord Med* 2009;32:560–7.
3. Gutierrez EM, Alm M, Hultling C, Saraste H. Measuring seat pressure, area, and asymmetry in persons with spinal cord injury. *Eur Spinal J* 2004;13:374–9.
4. Koo TKK, Mak AFT, Lee YL. Posture effects on seating interface biomechanics: comparison between two seating cushions. *Arch Phys Med Rehabil* 1996;77:40–7.
5. Consortium for Spinal Cord Medicine Clinical Practice Guidelines. Pressure ulcer prevention and treatment following spinal cord injury: a clinical practice guideline for health-care professionals. *J Spinal Cord Med* 2001;24(Suppl 1):S40–101.
6. Sprigle S, Maurer C, Holowka M. Development of valid and reliable measures of postural stability. *J Spinal Cord Med* 2007;30:40–9.
7. Karatas GK, Tosun AK, Kanath U. Center-of-pressure displacement during postural changes in relation to pressure ulcers in spinal cord-injured patients. *Am J Phys Med Rehabil* 2008;87:177–8.

8. Ferguson-Pell M, Hirose H, Nicholson G, Call E. Thermodynamic rigid cushion loading indenter: a buttock-shaped temperature and humidity measurement system for cushioning surfaces under anatomical compression conditions. *J Rehabil Res Dev* 2009; 46:945–56.
9. Pressure Ulcer Prevention Collaborative. Queensland Health. Pressure ulcer prevention and management guideline. Specialty fact sheet for practical considerations for clients with spinal cord injury. Available at http://www.health.qld.gov.au/patientsafety/puppp/documents/pup_spinal.pdf. Accessed February 21, 2011.
10. Dover H, Pickard W, Swain I, Grundy D. The effectiveness of a pressure clinic in preventing pressure sores. *Paraplegia* 1992; 30:267–72.
11. Connolly SJ, Miller WC, Trenholm K, Titus L, Moir S, Coulson S, et al. Wheeled mobility and seating equipment for the spinal cord injured individual. In: Eng JJ, Teasell RW, Miller WC, Wolfe DL, Townson AF, Hsieh JTC, et al, eds. *Spinal Cord Injury Rehabilitation Evidence*, 2010. Version 3.0. Available at <http://www.scireproject.com/>. Accessed December 10, 2011.
12. Thorfinn J, Sjoberg F, Lidman D. Sitting pressure and perfusion of buttock skin in paraplegic and tetraplegic patients, and in healthy subjects: A comparative study. *Scand J Plast Reconstr Surg Hand Surg* 2002;36:279–83.
13. Hamanami K, Tokuhiko A, Inoue H. Finding the optimal setting of inflated air pressure for a multi-cell air cushion for wheelchair patients with spinal cord injury. *Acta Med Okayama* 2004;58:37–44.
14. Di Marco A, Russel M, Masters M. Standards for wheelchair prescription. *Aust Occup Ther J* 2003;50:30–9.
15. Linder-Ganz E, Shabshin N, Itzchak Y, Yizhar Z, Siev-Ner I, Gefen A. Strains and stresses in sub-dermal tissues of the buttocks are greater in paraplegics than in healthy during sitting. *J Biomech* 2008;41⁽³⁾:567–80. Epub 2007 Dec 3.
16. Tam EW, Mak AF, Lam WN, Evans JH, Chow York Y. Pelvic movement and interface pressure distribution during manual wheelchair propulsion. *Arch Phys Med Rehabil* 2003;84:1466–72.
17. Sonenblum SE, Sprigle S, Maurer CL. Use of power tilt systems in everyday life. *Disabil Rehabil Assist Technol* 2009;4:24–30.
18. Michael SM, Porter D, Pountney TE. Tilted seat position for non-ambulant individuals with neurological and neuromuscular impairment: a systematic review. *Clin Rehabil* 2007;21:1063–74.
19. Ding D, Leister E, Cooper RA, Cooper R, Kelleher A, Fitzgerald SG, Boninger ML. Usage of tilt-in-space, recline, and elevation seating functions in natural environment of wheelchair users. *J Rehabil Res Dev* 2008;45:973–84.
20. Kennedy P, Berry C, Coggrane M, Rose L, Hamilton L. The effect of a specialist seating assessment clinic on the management of individuals with spinal cord injury. *J Tissue Viability* 2003;13:122–5.
21. Regan M, Teasell RW, Keast D, Aubut JL, Foulon BL, Mehta S. Pressure ulcers following spinal cord injury. In: Eng JJ, Teasell RW, Miller WC, Wolfe DL, Townson AF, Hsieh JTC, et al, eds. *Spinal Cord Injury Rehabilitation Evidence*, 2010. Version 3.0. Available at <http://www.scireproject.com/>. Accessed December 10, 2011.
22. Norton L, Sibbald RG. Is bed rest an effective treatment modality for pressure ulcers? *Ostomy Wound Manage* 2004;50:40–53.
23. Eggers SL, Myaskovsky L, Burkitt KH, Tolerico M, Switzer GE, Fine MJ, et al. A preliminary model of wheelchair service delivery. *Arch Phy Med Rehabil* 2009;90:1030–8.
24. Fogelberg D, Atkins M, Imperatore BE, Carlson M, Clark F. Decisions and dilemmas in everyday life: daily use of wheelchairs by individuals with spinal cord injury and the impact on pressure ulcer risk. *Top Spinal Cord Inj Rehabil* 2009;15:16–32.
25. Wheelchair. Guide To Selecting A Wheelchair Cushion. Available at <http://www.newdisability.com/wheelchaircushion.htm>. Accessed March 17, 2011.
26. Spinal Cord Injury Manual. A publication of the regional spinal cord injury center of delaware valley. 2001. Thomas Jefferson University. Available at <http://www.ascon.info/scibook-chp11.pdf>. Accessed March 17, 2011.
27. Li S, Wang J, Zhang F, Zhang Z, Zhang Y, Gao L. A Custom-Contoured Cushion for Preventing Pressure Ulcers. *Biomedical Engineering and Informatics* 2009:1-4.
28. Ferrarin M, Andreoni G, Pedotti A. Comparative biomechanical evaluation of different wheelchair seat cushions. *J Rehabil Res Dev* 2000;37:315–24.
29. Giesbrech EM, Ethans KD, Stanley D. Measuring the effect of incremental angles of wheelchair tilt on interface pressure among individuals with spinal cord injury. *Spinal Cord* 2011;49:827–31.
30. Sonenblum SE, Sprigle SH. The impact of tilting on blood flow and localized tissue loading. *J Tissue Viability* 2011;20:3–13.
31. Aissaoui R, Lacoste M, Dansereau J. Analysis of sliding and pressure distribution during a repositioning of persons in a simulator chair. *IEEE transactions on neural systems and rehabilitation engineering* 2001;9:215–24.
32. Hobson DA. Comparative effects of posture on pressure and shear at the body-seat interface. *J Rehabil Res Dev* 1992; 29:21–31.

CONTENTS

PRINCIPLES	133
FOCUS ON THE PERSON WITH SPINAL CORD INJURY	133
Optimizing independence through training	133
Challenges to skin integrity	133
Physical conditioning	133
Role of mobility in pressure ulcer prevention	133
ASSESSMENT OF MOBILITY	134
INTERPROFESSIONAL APPROACH	134
Overview of assessment	134
Pressure ulcer risks associated with mobility and activity	135
Reassessment of mobility	136
INTERVENTION	136
GROSS MOTOR SKILLS TRAINING	136
Bed mobility	137
Repositioning in bed	138
Transitional movements	138
Transfers	138
Approaches to repositioning and transfers	140
Wheelchair skills and propulsion	140
Pressure-redistribution strategies	141
Pressure redistribution using functional movements	141
Intentional weight-shifting strategies	142
Standing	145
Walking	145
EXERCISE AND CONDITIONING	146
Health risks of inactivity	146
Exercise for pressure ulcer prevention	146
Muscle length and joint range of motion	146
Exercise and circulation	147
Focus on function	147
GLUTEAL NEUROMUSCULAR STIMULATION	147
Surface electric stimulation	147
Implanted percutaneous electrodes: a case study	148
Implanted electric stimulation system	148
CONCLUSIONS	149
REFERENCES	149

Principles

FOCUS ON THE PERSON WITH SPINAL CORD INJURY

To be successfully implemented, pressure ulcer treatment and prevention strategies must become so embedded in an individual's daily activities that they become routine actions. The task of reassembling daily life around these strategies can be difficult for the individual.^(1,2) Guidetti et al found that study participants expressed the desire to choose their actions in attempts to reclaim control over their bodies, which they related to regaining their identity.⁽²⁾ A critical component of making choices and having control is possessing the relevant knowledge. For people with pressure ulcers, that knowledge is understanding the pressure ulcer treatment and prevention strategies that need to be implemented and ways in which they can be implemented.⁽¹⁻⁴⁾ Focusing training and education on the needs of the person with spinal cord injury makes training more relevant and respects individual priorities and perspectives.

Optimizing independence through training

A major focus and goal of rehabilitation for people with spinal cord injury is optimizing functional independence and efficiency of movement in gross motor skills. Gross motor skills encompass all aspects of bed mobility, transitional movements, transfers, wheelchair mobility, and gait.^(5,6) Independent mobility, which fosters self-management and feelings of control, must always be a priority in spinal cord injury rehabilitation. The goal of rehabilitation and gross motor skills training is to promote recovery — not compensation. Compensatory strategies may, however, be necessary for pressure ulcer prevention and management in people who remain dependent on a wheelchair for basic mobility.

CHALLENGES TO SKIN INTEGRITY

Extensive wheel chair use, numerous transfers, and exertion-induced physiologic changes during mobility through participating in daily activities are tremendous challenges to skin integrity. Interface pressures during sitting are four to five times higher in people with spinal cord injury than in able-bodied individuals, and these forces are magnified during movement, such as wheelchair propulsion.⁽⁷⁾ Active people with paraplegia perform multiple transfers daily. If these gross motor skills are not performed correctly, sudden trauma or repeated stress can produce skin injury.

Physical conditioning



Significant motor impairment leaves people with spinal cord injury fewer muscle groups to generate movement.

People with spinal cord injury must also build strength and endurance, challenge balance and coordination, and sustain cardiopulmonary conditioning by maintaining regular physical activity. Carefully integrating maximal physical abilities, appropriate adaptive equipment, and a supportive physical and social environment facilitates attainment and maintenance of optimal functional ability.

ROLE OF MOBILITY IN PRESSURE ULCER PREVENTION

Mobility poses significant challenges to skin integrity, and people who require a wheelchair for ambulation have one of the highest risks of developing a pressure ulcer. Gélis et al collated data from 14 relevant studies involving 12,466 participants with chronic spinal cord injury.⁽⁸⁾ Low functional independence measure (FIM) scores and low mobility were risk factors that predicted pressure ulcer occurrence with moderate strength.

Falls or bumps during transfers or other transitional movements can be pivotal events in pressure ulcer development.

Aging and deconditioning are associated with a decrease in gross motor skills quality and a concomitant increase in the risk of trauma and pressure ulcers.

A higher functional level at discharge from interdisciplinary specialized rehabilitation, indicated by higher FIM motor scores, is associated with a lower incidence of pressure ulcers.⁽⁹⁾ Yozbatiran et al measured balance and leg strength in 21 people with spinal cord injury receiving outpatient rehabilitation.⁽¹⁰⁾ Significant improvement was seen in several American Spinal Injury Association (ASIA) sensory and motor scores after 6 months; improved leg strength was associated with reductions in pressure ulcers.⁽¹¹⁾ Integrating principles of normal movement and motor relearning into therapeutic interventions can improve ease and efficiency of movement and increase potential gain in functional abilities.^(12,13) Emerging research evidence suggests that regular follow-up in specialized clinics or outreach programs improves functional outcomes and individual satisfaction. *Research is needed to determine to what extent follow-up rehabilitation helps maintain gross motor skills can prevent and treat pressure ulcers.*



Assessment of mobility

INTERPROFESSIONAL APPROACH

Practising within a specialized interprofessional spinal cord injury team facilitates communication, reduces duplication of data collection, and incorporates the expertise of clinicians with the greatest skills in managing this population. Within this context, a therapist is better able to identify relevant physical impairments, plan appropriate gross motor skills training, and set meaningful and realistic functional goals. The interprofessional approach allows the physiotherapist to develop a program within the context of the physiotherapy assessment, incorporating data from assessments performed by other professionals on the team.

Gross motor skills assessment allows a trained therapist to determine an individual's potential functional level, identify related pressure ulcer risks, and develop options for gross motor skills training. To complete a comprehensive assessment and propose an appropriate individualized care plan, the therapist must be aware of information that may have been gathered by other interdisciplinary team members, including the following:

- Neurologic level of injury and related physical impairments
- Comorbidities and related medical conditions, such as cardiopulmonary disease
- Health status and nutrition
- Communication or cognitive deficits
- Psychosocial issues:
 - » Psychological disorders
 - » Limitations to social supports and finances
- Goals of the person with spinal cord injury

 **APPENDIX 8A** provides an example of a tool for recording mobility assessment results

Overview of assessment



7.1: Mobility assessment

Ensure that a skilled therapist who is part of the interprofessional spinal cord injury team performs a comprehensive assessment of mobility, including evaluation of physical impairments, gross motor skills, and movement quality.

RECOMMENDATION LEVEL IV

The following components are considered essential elements of a comprehensive mobility assessment:

- Physical impairments:
 - » Sensation: cutaneous, proprioceptive, and pain
 - » Joints: range of motion
 - » Muscles: flexibility, strength, tone, and reflexes
 - » Motor function: selective control and coordination
 - » Posture: postural alignment, postural control, and dynamic balance
 - » Cardiorespiratory/activity tolerance
- Gross motor skills:
 - » Bed mobility: rolling, shifting, and repositioning
 - » Transitional movements: recumbent to long sitting, recumbent to high sitting, sitting to standing
 - » Transfers: to all functionally relevant surfaces
 - » Wheelchair skills: propulsion and pressure-redistributing movements
 - » Ambulation
- Movement quality:
 - » Use of normal movement patterns
 - » Level of control and care during movements: ability to prevent trauma in moving the body or limb onto or off different surfaces
 - » Impact of fatigue: deterioration in movement quality during the day or with muscle fatigue

A mobility assessment includes determining the degree of physical impairment, the current gross motor skills level, movement quality, and potential for recovery of reciprocal stepping. Optimizing movement quality can increase efficiency and ease of movement, improve control during transitions and transfers, and minimize the risk of pressure ulcer development.⁽⁶⁾ It is also important for the clinician to consider pressure ulcer risks related to gross motor skills, environmental factors, and the individual's equipment. This detailed assessment can help the clinician understand the relation between an individual's impairments, his or her impact on function, and pressure ulcer risks. Mobility assessment is linked to the comprehensive seating assessment.  **CHAPTER 4, Principles of pressure management, describes this relation and discusses the 24-hour approach to pressure management and principles for assessment and intervention.**

PRESSURE ULCER RISKS ASSOCIATED WITH MOBILITY AND ACTIVITY

7.2: Pressure ulcer risks associated with mobility and activity

Evaluate pressure ulcer risks associated with movement during the mobility assessment, including the following:

- Adequacy of postural support in all positions to reduce the risk of shear due to sliding
- Protection of vulnerable bony prominences from trauma at rest and during movement
- Amount of lift off different surfaces achieved by the individual during movement to minimize friction
- Safety of environmental configuration to minimize the risk of trauma and falls, including maintaining all transfer surface heights as equal as possible
- Level of attention the individual gives to movement quality
- Identification of factors that interfere with movement quality or safety

RECOMMENDATION LEVEL IV

As part of the mobility assessment, the clinician evaluates specific factors, activities, or situations that can produce forces of pressure, friction, or shear during movement. Factors such as pain, contractures, abnormally high or low muscle tone, muscle weakness, reduced selective motor control, reduced postural control, postural asymmetries, and deconditioning can all reduce the ease and quality of gross motor skills, the ability to perform controlled movements, and the incentive for movement. In turn, these factors can increase the risk of skin damage and pressure ulcer development. Individual



anthropometrics and measurement ratios can also affect these factors. For example, individuals with a short arm-length-to-trunk ratio may be unable to achieve buttock clearance off a surface.

Reassessment of mobility



7.3: Reassessment

Reassess gross motor skills abilities and current pressure management strategies if gross motor function declines or a pressure ulcer develops.

RECOMMENDATION LEVEL IV

Numerous factors can compromise functional independence, including equipment and environmental changes, medical illness, surgical procedures, fatigue, and advancing age. All of these can affect strength, coordination, and conditioning, reducing activity and participation and increasing the risk of bumps, falls, and skin trauma.



A decline in function or development of a pressure ulcer signals the need for a full interprofessional reassessment to clarify the clinical picture, including assessment of current pressure management strategies.

Reassessment assists in identifying possible causes of skin breakdown and appropriate interventions to meet individual needs. Rehabilitation may be required to retrain gross motor skills and reclaim functional independence by modifying transfer techniques, adapting to new equipment, or incorporating more assistance.

At the same time, it is critical to understand and manage pressure ulcer risks inherent in gross motor skills. As gross motor skills abilities and related pressure ulcer risks are context dependent, assessment and training must incorporate the situations involved in all daily activities. An important goal of gross motor skills training is to perform functional movements, such as transfers, as independently, safely, and normally as possible.



The presence of a pressure ulcer should be viewed as a possible physical symptom of impaired or lost gross motor skills and a cue to re-evaluate gross motor skills and functional movements as possible causes of skin injury.

Intervention

GROSS MOTOR SKILLS TRAINING



7.4: Gross motor skills training

Include gross motor skills-specific training in the plan of care for bed mobility, transfers, wheelchair mobility, and ambulation, as appropriate.

RECOMMENDATION LEVEL IV

The optimal approach to gross motor skills training is one that integrates the activities into a person's normal daily activities, rather than increasing time spent on self-care. The best way to accomplish this integration can only be determined in consultation with the individual.

Gross motor skills-specific training optimizes independence and reduces pressure ulcer risk. It is therefore important for individualized lifelong gross motor skills management strategies to target residual physical impairments and promote a healthy, active lifestyle. Strategies are specifically aimed at preserving joint range of motion, managing muscle tone, maintaining or improving strength and overall conditioning, and preserving postural alignment. Active and active-assisted movements maintain the functional length of all muscles, especially two-joint muscles.

It is also important for normal movement, motor relearning principles, and restorative strategies to be integrated into gross motor skills training to optimize functional possibilities and the quality, efficiency, and safety of movement. Principles of normal movement, motor relearning, and restorative strategies include the following:

- Optimize sensory cues to influence motor response.
- Maximize loading on load-bearing joints of the leg.
- Minimize compensatory strategies, including overuse of the arms.
- Integrate movements into daily activities and exercises for reinforcement.

These principles work together to enhance selective and coordinated motor responses and integrate automatic systems of postural control and more automatic gross motor responses.

Bed mobility

7.5: Pressure management and bed mobility

Optimize independent bed mobility skills and encourage the person with spinal cord injury to change positions regularly throughout the day to offload and redistribute pressure.

Consider training for bed mobility skills through the long-sitting position for individuals who cannot perform active pelvic and leg adjustments.

RECOMMENDATION LEVEL IV

👁️ **CHAPTER 5, Beds, mattresses, and recumbent positioning, includes information about supine, side-lying, and prone positioning.** People with spinal cord injury learn rolling, shifting, and repositioning movements to redistribute pressure and improve function and comfort. Individuals who lack the ability to perform active adjustments to pelvic and leg position may be able to perform shifting and transitional movements into and out of a side-lying position through a long-sitting position (Figure 1: Transitional movements).^(5,6)

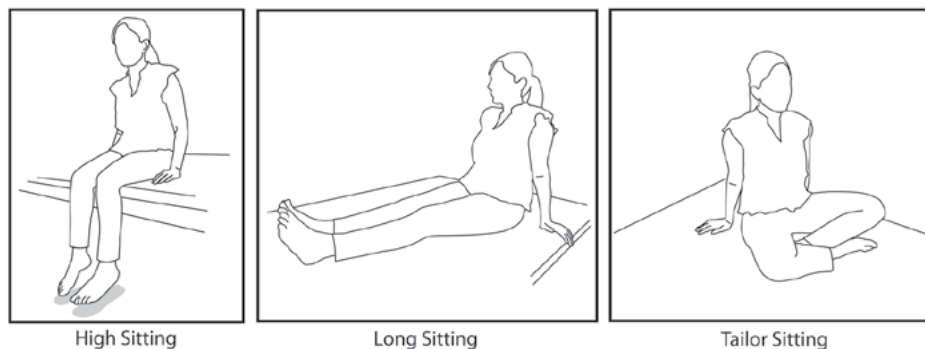

Figure 1. Transitional movements a) High sitting, b) Long sitting, c) Tailor sitting.

Learning to roll into and out of the prone position is beneficial, as the prone position can help manage spasticity, stretch the anterior myofascia, and offload the sacrum and ischial tuberosities. In the prone position, it is important to reduce the risk of pressure ulcers on the frontal aspect of the body by using a prone pillow and supporting the abdomen and ankles with pillows.

The transition from supine to long sitting or tailor sitting is a functionally useful skill for many individuals who cannot actively perform aspects of bed mobility and leg management in recumbent positions. In the long- or tailor-sitting position, the arms are used to reposition and manage the legs.^(5,6) Adaptive equipment can reduce friction and shear and facilitate these movements: for example, the use of sliders, bed rails, or trapeze bars to assist people with spinal cord injury to lift, rather than drag, their body.

Re-evaluation of and retraining for transitional movements and bed mobility skills may be necessary for individuals who are spending more time in bed due to an illness or injury.



Bed repositioning skills are essential when sitting time is restricted.

REPOSITIONING IN BED

 **CHAPTER 5, Beds, mattresses, and recumbent positioning, includes information about repositioning.**



Regardless of the pressure redistribution capabilities of a bed or mattress, repositioning is still necessary to manage pressure and numerous other complications of bed rest, such as deep vein thrombosis and pneumonia.⁽⁷⁾ Factors affecting repositioning are the individual's ability to manage bed mobility, the time each position is tolerated, and support surface considerations.

Repositioning and transitional movements on bed support surfaces must be performed properly and carefully to prevent friction and shear.

Transitional movements

Transitional movements are movements linking resting positions. Transitional movements typically include the following^(5,6):

- Lying-to-sitting transitions:
 - » High sitting: sitting on edge of a surface with legs down
 - » Long sitting: sitting with legs straight out
 - » Tailor sitting: sitting with legs crossed on a mat
- Sitting-to-standing transitions

Changing resting positions using transitional movements redistributes and offloads pressure but can generate forces of friction, shear, and pressure, causing tissue trauma. It is important to assess an individual's gross motor skills techniques in transitional movements to minimize these risks, as changing positions regularly throughout the day reduces pressure ulcer risk. A greater ability in executing gross motor skills minimizes the risk of pressure ulcers due to force and trauma. Gross motor skills are also integral to pressure management.

Transfers



7.6: Transfers

Select and train transfer techniques to all surfaces necessary for daily activities to ensure safe repositioning and minimize skin and tissue damage during movement.

Teach transfers to all surfaces necessary for daily activities, as risks and abilities are context dependent.

Consider alternative transfers if commonly used transfers cannot adequately support independence and pressure ulcer prevention.

RECOMMENDATION LEVEL IV

The most commonly used transfers are the following:

- Mechanical lift for higher cervical injuries
- Sliding board
- Leg-down lateral lift
- Low pivot
- Standing pivot



Figure 2. Transfer. Leg down lateral lift Figure 3. Transfer. Sliding board transfer Figure 4. Transfer. Standing pivot transfer

Alternative transfers include, but are not limited to, the leg-up lateral lift, towel transfer, towel transfer with sliding board, and leg-up frontal-approach transfer.⁽⁵⁾ When executing any transfer, it is important to decrease the distance travelled by minimizing the gap between transfer surfaces. People with spinal cord injury also need to develop body awareness, so that they are aware of the position of different parts of the body during transfers to prevent skin and tissue trauma during movement.

It is important to assess training for all transfers to surfaces needed for activities of daily living individually, as both risks and abilities depend on the environmental context. An individual who can safely perform a lateral lift from wheelchair to bed may not have adequate strength and control to perform this transfer into a vehicle where the transfer gap is greater. In this situation, a sliding board may solve the problem. If commonly used transfers cannot be integrated safely, alternative transfers may optimize independence and pressure management.

Any poorly performed transfer increases the risk of injury. The concepts of adequate lift, control of body and limb placement, and environmental configuration are especially critical to preventing injury. When transferring between support surfaces, people with spinal cord injury need to learn the importance of lifting the body away from the support surface to avoid dragging.

The degree of postural control and leg motor function determines whether transfers are performed through sitting or through standing. Transfer training requires special attention to the following:

- **Path between transfer surfaces:** This should be clear of obstacles, including armrests, footrests, and clothing guards, to reduce risk of contact injury.
- **Height differential between transfer surfaces:** A level or slightly downhill transfer optimally facilitates ease of transfer and surface clearance.
- **Transfer gap:** Placing the wheelchair parallel or at a slight angle to the transfer surface creates the smallest gap and transfer distance.
- **Ensuring buttock offloading and careful placement throughout the transfer:**
 - » Sliding board transfers require the buttocks to be supported on the board throughout the transfer, from initial board placement.
 - » A slider sheet or towel may be needed on the sliding board to reduce friction and shear in some situations, such as transferring an unclothed individual.

- » Care is required to prevent the buttocks dragging across or bumping down onto the rear wheel of the wheelchair.
- » A controlled descent onto the transfer surface prevents skin trauma that could occur with bumping down onto the surface.
- **Ensuring foot contact with the floor to maximize leg loading during transfers:**
 - » Maintenance of contact with the floor, with the feet under the body as much as possible, provides a reference for the movement, reduces the risk of sliding forward, and may help control spasticity.
 - » Careful attention to foot placement throughout the transfer can prevent trauma from torsion.
 - » Safe transfers require proper footwear.
- **Preventing overuse injuries during transfers involving arm loading:**
 - » Movements must be performed in a controlled manner.
 - » Incremental movements to the transfer surface reduce risks.
 - » Alternating transfer direction reduces the risk of repetitive strain injury.

APPROACHES TO REPOSITIONING AND TRANSFERS

The following principles increase the safety of repositioning, transitional movements, and transfers.

- *Lift — do not drag — a person across a support surface.*
- *Use slider sheets to reduce friction and facilitate moving the individual when lifting is not feasible.*
- *Choose smooth, low-friction, breathable materials for sheets, pajamas, mechanical lifts, and slings.*
- *Consider adaptive equipment to assist repositioning and transfers, such as sliding boards, bed rails, and trapeze bars. Objects in the immediate environment, such as armrests, backrests, and parts of the wheelchair frame may also be used to assist repositioning and transfers.*
- *Use mechanical lifts or slings if necessary.*
- *Minimize effort during transfers by equalizing surface heights and minimizing the gap between surfaces.*
- *Preserve shoulder function and avoid repetitive strain injury to the arm during movement.*
- *Ensure the person with spinal cord injury is correctly positioned so that the movement is performed in a controlled manner.*
- *Use care in repositioning people with spinal cord injury to prevent friction and shear from stretching the skin or folding soft tissues during movement.*

Wheelchair skills and propulsion

7.7: Wheelchair skills

Integrate controlled simulations into a formalized wheelchair skills training program.

RECOMMENDATION LEVEL 1B

Two randomized controlled clinical trials measured wheelchair skills in people with spinal cord injury using a previously validated wheelchair training test.^(14,15) The research compared participants who had received a formal wheelchair skills training program with a control group that had received no formal training. Specific training in wheelchair skills, during initial rehabilitation or in the community, significantly improved skills. Controlled simulations in wheelchair skills training also improved independence and freedom of movement.^(14,15) This training is also expected to improve quality of life.

Appropriate wheelchair configuration, postural supports, and sitting surface height are integral to optimizing wheelchair skills and reducing the risk of pressure ulcers. Wheelchair propulsion is associated with extremely high interface pressures. The location of these peak pressures differs from those recorded during sitting, and these pressures vary with movement.⁽¹⁶⁾  **CHAPTER 6, Wheelchairs and other seating, includes a detailed review of wheelchair posture, positioning, equipment, support surfaces, and other seating.**

Training in wheelchair skills is an important therapeutic element. Independence in wheelchair propulsion, optimization of push stroke, and proficiency in wheelchair skills all increase mobility. In turn, the postural changes inherent in functional activities automatically redistribute pressure. At the same time, the association of self-propulsion with greater postural changes increases the risk of friction and shear. Optimizing trunk control against gravity and postural responses can



increase the ability to maintain postural alignment and tolerate displacement. Improved control reduces risks associated with asymmetrical loading and shear. Advanced wheelchair skills also increase musculoskeletal demands and the risk of trauma due to falls.

Pressure-redistribution strategies

Pressure redistribution may occur as a result of intentional weight-shifting movements or be inherent in daily activities. Weight-shifting movements include active movements and technology-assisted movements; they may be initiated by the individual or occur automatically.

7.8: Individualizing weight-shift strategies

Individualize pressure-redistributing strategies using a variety of weight-shifting approaches including automatic pressure redistribution with functional movement, active lifting or shifting, and dynamic weight shifts (tilt and recline) with and without power-assist.

Base the duration, frequency, and amount of active or power-assisted weight-shifting on the individual skin response and the effectiveness of the strategy across the full day.

RECOMMENDATION LEVEL III

7.9: Evaluating pressure-redistributing movements

Use manual palpation, observation, and pressure mapping, as appropriate, to evaluate the effectiveness of weight-shifting strategies.

Incorporate information about effective use of weight-shifting strategies, including demonstrations, into the individual's pressure management plan.

RECOMMENDATION LEVEL IV

Little evidence is available to guide recommendations for performing pressure-redistributing movements.⁽⁵⁾ To return tissue oxygenation to unloaded levels, however, a pressure-relieving movement must be at least 1 to 2 minutes in duration.⁽¹⁷⁾ Sustaining a vertical lift for this length of time is simply not possible for most people with spinal cord injury.

PRESSURE REDISTRIBUTION USING FUNCTIONAL MOVEMENTS

7.10: Automatic pressure redistribution with functional movements

Ensure that an individual who does not use active or dynamic intentional weight shifts to redistribute pressure performs more frequent skin checks if activities or daily routines change.

Balance the benefits of frequent functional movements performed throughout the day while in the wheelchair with the potential risk of injury due to friction and shear.

RECOMMENDATION LEVEL IV

Weight shifting occurs naturally when a person is actively moving within or across surfaces and during functional activities, such as pulling, pushing, squatting, and balancing. Active individuals, who perform some or all movements needed for wheelchair propulsion and transfers, redistribute pressures automatically multiple times throughout the day. This activity may be sufficient to protect the skin from excess or prolonged pressure. Careful monitoring of skin condition, however, is needed to ensure daily activities do not traumatize the skin or cause deep tissue injury. Although repeated low-intensity, functional movements can provide skin protection and conditioning, excessive or over-frequent movements can lead to pressure ulcers.



Functional movements shift pressure and the centre-of-mass over a base of support, while generating friction and shear. For example, as pelvic tilt changes during propulsion or reaching activities, the ischial tuberosities move across the sitting surfaces. These movements can improve tissue perfusion, which may be sufficient to reduce pressure ulcer risk. Wheelchair propulsion can generate significant external forces and frequent challenges to skin integrity.^(7,16) These forces, however, are spread over larger body areas and seldom occur for extended periods of time. It is therefore important to consider the duration of these functional movements in conjunction with other pressure management techniques. Changes to an individual's level or type of activity may produce uneven or concentrated pressures, increasing the risk of skin breakdown.

INTENTIONAL WEIGHT-SHIFTING STRATEGIES

7.11: Active weight shifting: leaning forward and to the side

Encourage leaning forward or to the side, as this produces more complete and prolonged pressure reductions than lifting vertically.

Educate people with spinal cord injury about the risks and benefits of active weight-shifting (intentional pressure redistribution) techniques. Work with the individual to select a technique (lifting or leaning) and frequency that best meets that person's needs.

RECOMMENDATION LEVEL IV

Intentional weight-shifting techniques commonly taught to people with spinal cord injury include the following:

- Push-up:** The traditional recommendation to manage pressure has been lifting or pushing up off the seat every 15 minutes for 2 minutes. Increasing evidence points to the inadequacy of this technique, as the lifted position is not sustainable for this duration or frequency. It is also important to consider the potential for shoulder damage resulting from frequent repetition. This technique may, however, be effective in repositioning the body for comfort, for stretching, or for postural adjustments, such as correcting a postural shift.

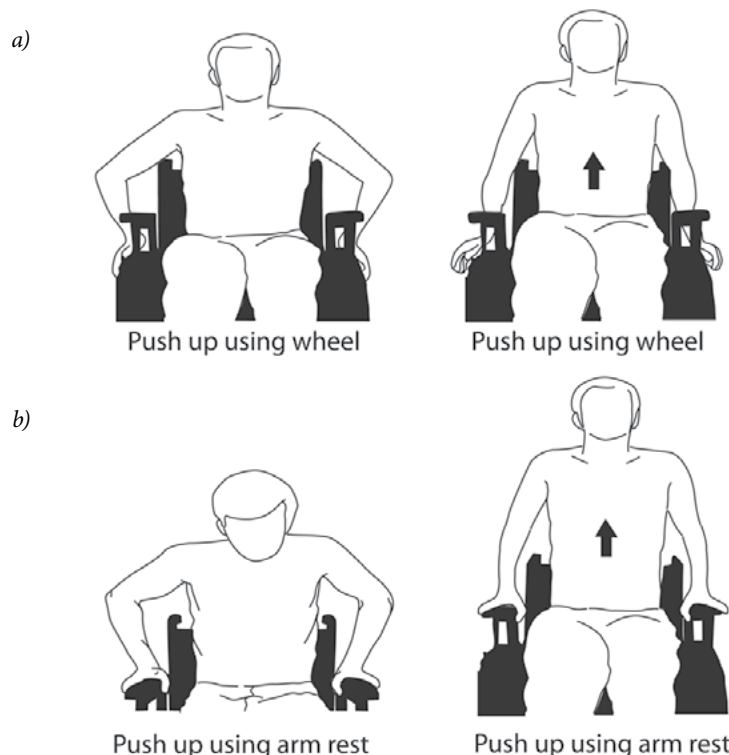

Figure 5. Weight Shift. Push up using a) wheel, and b) arm rest

- Leaning to the side:** Leaning to the side is effective in shifting weight off the opposite buttock, but this movement requires adequate strength and trunk control. The degree of lateral movement determines the amount of pressure redistribution. No amount of weight shifting, however, has been demonstrated to provide adequate pressure redistribution for pressure ulcer prevention. It is unclear whether shifting the trunk, but not the pelvis, provides adequate pressure management. The ability to return to the original upright position is an important consideration when recommending this technique, as failure to return to a balanced upright posture may lead to postural asymmetries.

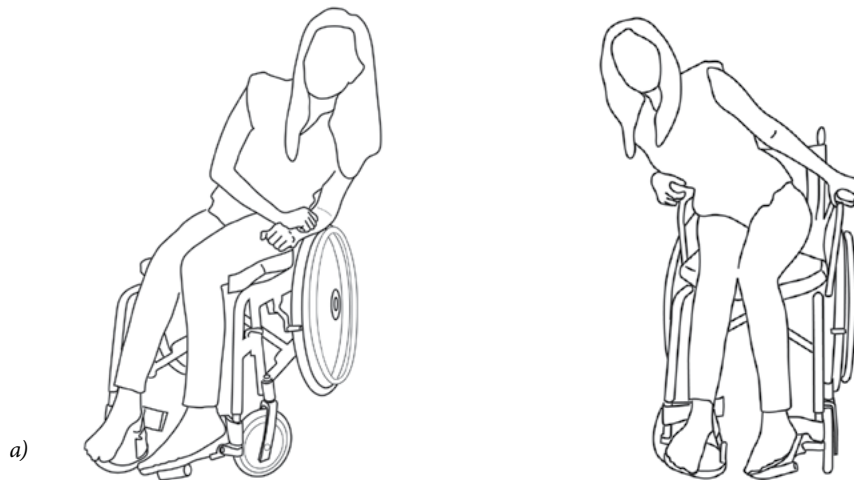

Figure 6. Weight Shift. Lateral Shift using a) wheel, and b) arm rest

- Leaning forward:** Leaning forward is an effective weight-shifting technique to redistribute sitting pressures. Forward leaning appears easier to do and is more functional than leaning to the side or pushing up. It is also a more socially accepted posture to assume for 2 minutes and may therefore be easier to integrate into daily activities. Environmental supports can also be used, such as a table or the bathroom vanity during teeth brushing. Studies have reported maximal reduction in ischial tuberosity pressure at a 45° forward angle⁽¹⁸⁾ and at 50° of forward leaning.⁽¹⁹⁾ Even forward leaning of 30° shifted the ischial tuberosities.⁽¹⁸⁾ This technique may be inappropriate in some situations, such as soon after skin surgery.



Figure 7. Weight Shift. Leaning Forward



Figure 8. Weight Shift. Leg Lift

- **Supine positioning:** Adopting a supine position regularly during the day is an option to offload pressure for people who are unable to perform other manual techniques and for whom use of dynamic weight-shifting positioning technology, such as tilt, is not desired or feasible.

Pressure-redistributing manoeuvres can significantly reduce pressure under the ischial tuberosities.⁽¹⁹⁾ The optimal type, length, and frequency of pressure-redistributing movements must be individualized for each person with spinal cord injury, using pressure mapping or other objective measures.



Weight shifting offloads pressure from bony prominences to manage sitting pressure.⁽¹⁹⁾ *More research is needed to determine whether decreasing ischial pressure and/or increasing blood flow to tissues during weight-shifting techniques and pressure-redistributing movements reduces the incidence of pressure ulcers.* Risk reduction depends on the effectiveness of the technique, which in turn depends on the amount of weight shifted away from the area of concern, the duration of the movement, and, usually, the range of motion. Of equal importance in assessing effectiveness of a movement is the ability to return to a balanced posture, as a movement that ends in an asymmetrical posture or produces sliding reduces overall benefits.

Redistributing pressure or offloading bony prominences through intentional postural changes effectively reduces the risk of pressure ulcers.⁽⁶⁾



Although effectiveness of performing some techniques can be assessed by sliding a hand under the unweighted area to determine clearance, by observing skin changes, or by mapping interface pressure, no method measures the effectiveness of techniques in reducing pressure ulcer risk. Pressure mapping never replaces palpation and visual inspection.

Interface pressures measured under people with tetraplegia indicated that leaning forward produced more sustained and complete pressure relief under the ischial tuberosities than lifting vertically.⁽¹⁷⁾ No evidence indicates lifting is more effective than leaning in redistributing pressure; in addition, many people have difficulty maintaining a lift for the necessary time. It has been suggested that individuals alternate movements and use adaptive strategies to help make these movements more passive and reduce repetitive strain injuries. These results are consistent with evidence reviewed by Spinal Cord Injury Rehabilitation Evidence (SCIRE).⁽²⁰⁾

During rehabilitation, people with spinal cord injury learn pressure-redistributing movements to reduce pressure ulcer risk, and clinicians recommend performing these movements throughout the day. Surveys, however, suggest that people with spinal cord injury seldom perform active weight shifts regularly throughout the day.^(21,22) When asked about activities that prevent pressure sores, few people valued daily routines that included pressure-redistributing lifts or weight shifts. More commonly, people who noticed reddening or impending skin breakdown simply spent more time recumbent. This approach trades off participation in pleasurable activities and social interaction for performing pressure-redistributing movements. Therefore, encouraging people with spinal cord injury to integrate pressure-redistributing movements into daily functional movements may motivate them to perform pressure-redistributing movements more frequently.

Performing movements independently allows the person to tailor the regimen to individual needs and lifestyle. When individuals lack the strength or ability to shift their own body weight, however, assistive technology can be helpful, such as tilt-and-recline features in wheelchairs or other seating systems.⁽²³⁾  **CHAPTER 6, *Wheelchairs and other seating, provides information about power tilt-and-recline.***

Standing

7.12: Standing

Consider individual risks of standing and encourage appropriate individuals to stand with a support, such as a standing frame or alternative device.

RECOMMENDATION LEVEL III

Physiologic and psychological benefits of prolonged standing include improved circulation, digestion, respiration, bowel and bladder activity, sleep pattern, pain, and spasticity.^(23,24) In addition to offloading and redistributing pressure, prolonged weight bearing in the standing position can maintain hip and knee extension and ankle dorsiflexion range and reduce postural hypotension and hypercalciuria. The sitting-to-standing transition carries a risk of shear. Teaching this transition must consider individual factors that may be associated with risk, including orthostatic hypotension, bone fragility, contractures, deformities, and skin-loading tolerance.

A focus on normal movement and motor retraining principles during sitting-to-standing transitions is especially important to improve the ease, quality, and safety of this higher-level transition. Individuals who cannot actively stand may find a standing frame or alternative standing device a valuable substitute. Standing frames use various technologies and most now incorporate articulating frames or ways to minimize the shear forces that are exerted during transitional movements, but it is still important to consider the risk of shear.

People with spinal cord injury who regularly used standing as part of their exercise programs have a lower incidence of several medical complications, including pressure ulcers.⁽²⁴⁾ Studies have demonstrated that blood flow in the legs was reduced significantly during standing,^(25,26) and it has been suggested that decreased tissue perfusion during standing could interfere with healing of pressure ulcers located on the foot and ankle. It is therefore important to assess the relative risks and benefits of therapeutic standing in each individual.

Walking

7.13: Walking

Encourage walking in appropriate individuals where appropriate footwear and leg support can be provided.

RECOMMENDATION LEVEL III

Individuals who achieve ambulation typically reduce their risk of pressure ulcer development.⁽²⁷⁾ However, unperceived trauma from poorly fitting footwear and leg braces can cause pressure ulcers, and an unprotected foot can be injured by stepping on a sharp or rough object.

People with spinal cord injury, who have impaired sensation in the feet, have an increased risk of joint injury. Marked joint deformity and skin ulceration over a bony prominence may result if trauma is not identified promptly and treated properly.⁽²⁸⁾ Osseous microtrauma to an insensate joint during ambulation can result in Charcot (neuropathic) joint, most commonly in the foot and ankle. Monofilament testing for protective sensation can identify these risks.⁽²⁹⁾ Prevention of Charcot joint involves lifelong protection, with professional foot care, custom footwear, and possibly bracing.⁽³⁰⁾ Bracing to manage a Charcot joint or residual motor deficits can, however, reduce gait quality and efficiency and increase the risk of skin damage.

Although ambulation has substantial benefits in preventing sitting-acquired pressure ulcers in people with spinal cord injury, ambulation is also associated with risks. Appropriate candidates for ambulation are people who are less likely to encounter significant joint and skin trauma, and supervision by a skilled therapist, who introduces a gait retraining program gradually while watching for signs of joint and skin injury, is needed for safety.



EXERCISE AND CONDITIONING

Health risks of inactivity

Buchholz et al examined 76 adults with spinal cord injury of at least 1 year's duration to determine the relation between physical activity and risk factors for cardiovascular disease and type 2 diabetes.⁽³¹⁾ The participants were divided into groups according to daily physical activity. The authors compared the group reporting no activity (n=28) with an equal number of the most active individuals (activity \geq 25 minutes). Active individuals had significantly lower body mass index (BMI) (18.7%); fat mass percentage (19.4%); and C-reactive protein (CRP) (14.3%), a marker of both inflammation and cardiovascular risk; and significantly greater fat-free mass percentage (7.2%) (all $p \leq .05$). Significantly lower waist circumference (17.6%) and systolic blood pressure (15.3%) were also seen in active, compared with inactive, individuals with paraplegia (both $p \leq .05$) but not in those with tetraplegia. The frequency of insulin resistance significantly ($p = .03$) differed between the groups. Insulin resistance was found in 10% of active and 33% of inactive participants. Just as in able-bodied individuals, physical activity reduces risk factors associated with cardiovascular disease and type 2 diabetes in people with spinal cord injury.

A cross-sectional study in 69 adults with spinal cord injury examined cardiovascular risk factors including CRP.⁽³²⁾ The mean CRP was $3.37 \pm .86$ mg/L, indicating high cardiovascular risk according to the American Heart Association definition. Tetraplegia and increased waist circumference were significantly associated with increased CRP.

Exercise for pressure ulcer prevention



7.14: Exercise for pressure ulcer prevention

Encourage the person with spinal cord injury to participate in regular exercise that is consistent with Canadian physical activity guidelines to optimize muscle strength and endurance, encourage postural alignment, improve cardiovascular endurance, and prevent fatigue and deconditioning.

RECOMMENDATION LEVEL III

Canadian physical activity guidelines for adults with spinal cord injury recommend moderate- or vigorous-intensity aerobic activity for at least 20 minutes and strength training, including three sets of eight to ten repetitions for each major muscle group, both twice a week.⁽³³⁾

Regular exercise and physical activity have numerous benefits. Exercise improves overall physical conditioning and quality of life and maintains joint range of motion, physical endurance, and mobility.⁽⁵⁾ Upper body strengthening improves lung function and the ability to manage activities of daily living, such as those involving transfers and negotiation of ramps. *The role of exercise in pressure ulcer prevention needs to be better defined through future research.*



MUSCLE LENGTH AND JOINT RANGE OF MOTION



7.15: Maintenance of range of motion and flexibility

Use active or active-assisted movements to maintain joint range of motion and muscle flexibility, when possible.
Use conventional passive range-of-motion programs for individuals without motor function.

RECOMMENDATION LEVEL IV

Wheelchair-dependent individuals have a high risk of contracture in two-joint muscles. It is therefore important to incorporate range-of-motion exercises specific to hamstring, rectus femoris, and gastrocnemius muscles into stretching routines. Sustained prone lying and supported standing in a standing frame also help maintain muscle length and range of motion.

Active or active-assisted movements are preferred to passive range-of-motion movements to maintain muscle length and joint range of motion, as they transmit more meaningful afferent input into the spinal circuitry than passive movements.^(34,35)

EXERCISE AND CIRCULATION

Although it has been suggested that passive range-of-motion leg exercise, either manually or via passive cycling, could improve arterial circulation, no change in peripheral circulation has been detected in studies after passive exercise of male participants with or without spinal cord injury.^(34,35)

Ter Woerds et al evaluated the impact of passive leg movements and passive cycling on the arterial circulation in individuals with spinal cord injury.⁽³⁴⁾ The study found no difference in cardiovascular function as a result of the intervention.

Passive range-of-motion exercises are not effective in improving circulation. The authors stated that these findings in no way negated the use of passive cycling to manage musculoskeletal problems.

Cotie et al performed a randomized crossover trial evaluating the effects of body-weight-supported treadmill and tilt-table standing training on skin temperature and blood flow in seven individuals after spinal cord injury.⁽²⁶⁾ Each intervention was implemented for 12 sessions (three times weekly for 4 weeks). No changes were seen in blood flow, but skin temperature decreased after training, although the changes were inconsistent. Increased skin temperature and a decreased skin temperature response have been associated with pressure ulcer development. These training interventions may improve skin temperature responses. *Additional research could clarify the impact of these training interventions.*

Focus on function

7.16: Functional activities

Integrate daily exercise routines into functional activities to support recovery and maintain physical and functional abilities.

RECOMMENDATION LEVEL IV

Individual functional needs should form the basis of conditioning and strengthening programs. For example, triceps-specific strengthening may benefit an individual who is having difficulty offloading the buttocks during lateral-lift transfers. Integrating functional activities and daily exercise routines, such as incorporating daily standing when washing dishes, can also support recovery and maintain physical and functional abilities through the inherent physical demands of the activity.⁽³⁶⁾

GLUTEAL NEUROMUSCULAR STIMULATION

7.17: Electrical stimulation

Consider the use of electrical stimulation to decrease ischial pressure and increase blood flow to tissues.

RECOMMENDATION LEVEL IIA

Surface electric stimulation

 Regan M, Teasell RW, Keast D, Aubut JL, Foulon BL, Mehta S (2010). *Pressure Ulcers Following Spinal Cord Injury*. In Eng JJ, Teasell RW, Miller WC, Wolfe DL, Townson AF, Hsieh JTC, Connolly SJ, Mehta S, Sakakibara BM, editors. *Spinal Cord Injury Rehabilitation Evidence. Version 3.0. reviews research evidence on surface electrical stimulation.*

IMPLANTED PERCUTANEOUS ELECTRODES: A CASE STUDY

Regular use of neuromuscular electric stimulation, including implanted systems, can increase the size and health of stimulated muscles, increase blood flow, and improve the health of the surrounding tissues, in addition to significantly reducing ischial interface pressures.⁽⁴⁰⁾ These observations provided the rationale for developing an implantable gluteal stimulation system for a 42-year-old unemployed man with ASIA-A C4 spinal cord injury of 22 years' duration and a history of frequent pressure ulcers. The system consisted of two electrodes implanted on each side and a small external stimulator.

After a conditioning regimen, alternating left- and right-sided stimulation for 3 minutes out of every 20 provided weight shifting at an appropriate frequency. The system was used up to 10 hours a day for 6 months when the person was seated in a wheelchair.

Interface pressure decreased significantly within 6 weeks, with little additional change after 6 months. Weight-shifting effectiveness increased over 6 months and was then maintained. Sustained improvement in tissue oxygenation was seen. Sitting tolerance more than doubled from 6 to 12 hours.

Since beginning regular use of the system, the individual experienced one minor skin breakdown episode due to a poor transfer, which resolved with 2 days' bed rest. He was also able to work part-time. Beneficial effects were lost when stimulation was discontinued and regained when stimulation was resumed.

Implanting the electrodes close to the motor point of the relevant nerve decreases the charge necessary to generate therapeutic neuromuscular electric stimulation. It was also felt to be more effective than using surface electrodes, as the inferior gluteal nerve is deep within the buttock, and correct electrode positioning is difficult to achieve reliably. The authors concluded that long-term gluteal neuromuscular stimulation could reduce the risk of pressure ulcers and provide an adjunctive pressure relief system for high-risk individuals. For even greater ease and reliability during long-term use, a fully implanted system would be optimal.

Since the publication of SCIRE in 2010,⁽²⁰⁾ van Londen et al studied the effect of surface electric stimulation of the gluteal muscles on interface pressure in 13 people with spinal cord injury during a session in which alternating and simultaneous protocols were used in random order.⁽³⁷⁾ Surface stimulation was used as an alternative to implantation, as it may be more suitable for occasional use and a less costly approach than implantation. Both protocols significantly ($p < .01$) decreased interface pressures by an average of 18 mm Hg. Significant reductions were also seen in interface pressure gradients during stimulation, compared with the rest periods, with no difference between right and left sides. As absolute interface pressure thresholds for the development of pressure ulcers have not been established, it is not known whether these interface pressure reductions would be sufficient to prevent pressure ulcer development.

Implanted electric stimulation system

Two clinical studies evaluated the effect of electrical stimulation on reducing ischial pressures while sitting. Bogie and Triolo examined the effects of neuromuscular electrical stimulation delivered via an implanted neuroprosthesis on interface pressure distribution at the support surface interface.⁽³⁸⁾ After 8 weeks of neuromuscular electrical stimulation, mean interface pressures measured in the ischial regions were significantly decreased ($p < .01$). Lui et al studied the effects of electrical stimulation of the S2 nerve root via an implanted sacral anterior root stimulator.⁽³⁹⁾ When electrical impulses were delivered at an intensity sufficient to cause gluteal muscle contraction, peak interface pressures on the seating surface were reduced by 33% ($p < .01$). Based on this research, SCIRE concluded there is limited level IV evidence that electrical stimulation decreases ischial pressures after spinal cord injury.⁽²⁰⁾

CONCLUSIONS

Active participation in mobility and exercise is critical to an individual's independence and functional ability, and training in gross motor skills is a key component and goal of rehabilitation. Maintenance of strength and mobility over the individual's lifetime can significantly reduce the risk of pressure ulcer development. Long-term management strategies need to be individualized and focus on maintenance of functional activities.

The most effective program is one that is designed with a focus on the person with spinal cord injury. A program that integrates exercise into daily functional activities and simplifies the individual's life is far more likely to promote long-term adherence than a program that does not integrate physical activity into daily life.

REFERENCES

1. Clark FA, Jackson JM, Scott MD, Carlson ME, Atkins MS, Uhles-Tanaka D. Data-based models of how pressure ulcers develop in daily-living contexts of adults with spinal cord injury. *Arch Phys Med Rehabil* 2006;87:1516–25.
2. Guidetti S, Asaba E, Tham K. The lived experiences of recapturing self-care. *Am J Occup Ther* 2007;61:303–10.
3. Wilcock A. Occupation-focused preventative approach to illness and disability. In: A. Wilcock. *An Occupational Perspective on Health*. New Jersey: SLACK Incorporated; 2006. pp. 273–302.
4. Larsson Lund M, Nordlund A, Nygard L, Lexell J, Bernspang B. Perceptions of participation and predictors of perceived problems with participation in person with spinal cord injury. *J Rehabil Med* 2005;37:3–8.
5. Bromley I. *Tetraplegia and paraplegia. A guide for physiotherapists*. 6th edition. Philadelphia, PA: Churchill Livingstone Elsevier; 2006.
6. Freeman-Somers M. *Spinal Cord Injury: Functional Rehabilitation*. 3rd edition. Englewood Cliffs, NJ: Prentice Hall; 2010.
7. Tam EW, Mak AF, Lam WN, Evans JH, Chow YY. Pelvic movement and interface pressure distribution during manual propulsion. *Arch Phys Med Rehabil* 2003;83:1466–71.
8. Gélis A, Dupeyron A, Legros P, Benaïm C, Pelissier J, Fattal C. Pressure ulcer risk factors in persons with spinal cord injury. Part 2: the chronic stage. *Spinal Cord* 2009;47:651–61.
9. Wolfe DL, Hsieh JTC, Mehta S. Rehabilitation practices and associated outcomes following spinal cord injury. In: Eng JJ, Teasell RW, Miller WC, Wolfe DL, Townson AF, Hsieh JTC, et al, eds. *Spinal Cord Injury Rehabilitation Evidence*, 2010. Version 3.0.
10. Yozbatiran N, Harness ET, Le V, Luu D, Lopes CV, Cramer SC. A tele-assessment system for monitoring treatment effects in subjects with spinal cord injury. *Telemed Telecare* 2010;16:152–7.
11. Devillard X, Rimaud D, Roche F, Calmels. Effects of training programs for spinal cord injury. *Annales de réadaptation et de médecine physique* 2007;50:490–8.
12. Harkema S, Behrman A, Barbeau H. *Locomotor Training: Principles and Practice*. New York, NY: Oxford University Press; 2011.
13. Davies PM. *Steps to Follow. The Comprehensive Treatment of Patients with Hemiplegia*. 2nd edition. Berlin: Springer; 2000.
14. Kirby RL, Swuste J, Dupuis DJ, MacLeod DA, Monroe R. The wheelchair skills test: a pilot study of a new outcome measure. *Arch Phys Med Rehabil* 2002;83:10–8.
15. MacPhee AH, Kirby RL, Coolen AL, Smith C, MacLeod DA, Dupuis DJ. Wheelchair skills training program: a randomized clinical trial of wheelchair users undergoing initial rehabilitation. *Arch Phys Med Rehabil* 2004;85:41–50.
16. Van Kemenade CH. *Biomedical Aspects of Manual Wheelchair Propulsion: The State of the Art II*. Amsterdam: IOS Press; 1999.
17. Coggrave MJ, Rose LS. A specialist sitting clinic: changing pressure relief practice. *Spinal Cord* 2003;41:692–5.

18. Henderson JL, Price SH, Brandstater ME, Mandac BR. Efficacy of three measures to relieve pressure in seated persons with spinal cord injury. *Arch Phys Med Rehabil* 2008;87:750–7.
19. Hobson DA. Comparative effects of posture on pressure and shear at the body-seat interface. *J Rehabil Res Dev* 1992;29:21–31.
20. Regan M, Teasell RW, Keast D, Aubut JL, Foulon BL, Mehta S. Pressure ulcers following spinal cord injury. In: Eng JJ, Teasell RW, Miller WC, Wolfe DL, Townson AF, Hsieh JTC, et al, eds. *Spinal Cord Injury Rehabilitation Evidence*, 2010. Version 3.0. Available at <http://www.scireproject.com/>. Accessed December 10, 2011.
21. Sonenblum SE, Sprigle S, Maurer CL. Use of power tilt systems in everyday life. *Disabil Rehabil Assist Technol* 2009;4:24–30.
22. Ding D, Leister E, Cooper RA, Cooper R, Kelleher A, Fitzgerald SG, Boninger ML. Usage of tilt-in-space, recline, and elevation seating functions in natural environment of wheelchair users. *J Rehabil Res Dev* 2008;45:973–84.
23. Eng JJ, Levins SM, Townson AF, Mah-Jones D, Bremner J, Huston G. Use of prolonged standing for individuals with spinal cord injuries. *Phys Ther* 2001;81:1392–9.
24. Correa GI, Fuentes M, Gonzalez X, Cumsille F, Pineros JL, Finkelstein J. Predictive factors for pressure ulcers in the ambulatory stage of spinal cord injury patients. *Spinal Cord* 2006;44:734–9.
25. Nash MS, Jacobs PL, Montalvo BM, Klose KJ, Guest RS, Needham-Shropshire BM. Evaluation of a training program for persons with SCI paraplegia using the Parastep 1 Ambulation System. Part 5: lower extremity blood flow and hyperemic responses to occlusion are augmented by ambulation training. *Arch Phys Med Rehabil* 1997;78:808–14.
26. Cotie LM, Geurts CLM, Adams MME, MacDonald MJ. Leg skin temperature with body-weight-supported treadmill and tilt-table standing training after spinal cord injury. *Spinal Cord* 2011;49:149–53.
27. Agarwal S, Triolo RJ, Kobetic R, Miller M, Bieri C, Kukke S, et al. Long-term user perceptions of an implanted neuroprosthesis for exercise, standing, and transfers after spinal-cord injury. *J Rehabil Res Develop* 2003;40:241–52.
28. Shah M. Charcot arthropathy. Medscape Reference. Available at <http://emedicine.medscape.com/article/1234293-overview>. Accessed September 16, 2011.
29. Guzman A. Sensory examination. January 2011. Available at <http://www.scribd.com/doc/48234775/Sensory-Exam>. Accessed September 16, 2011.
30. Verity S, Sochocki M, Embil JM, Trepman E. Treatment of Charcot foot and ankle with a prefabricated removable walker brace and custom insole. *Foot Ankle Surg* 2008;14:26–31.
31. Buchholz AC, Martin Ginis KA, Bray SR, Craven BC, Hicks AL, Hayes KC, et al. Greater daily leisure time physical activity is associated with lower chronic disease risk in adults with spinal cord injury. *Appl Physiol Nutr Metab* 2009;34:640–7.
32. Gibson AE, Buchholz AC, Martin Ginis KA, SHAPE-SCI Research Group. C-reactive protein in adults with chronic spinal cord injury: increased chronic inflammation in tetraplegia vs paraplegia. *Spinal Cord* 2008;46:616–21. Epub 2008 Apr 15.
33. SCI Action Canada. Physical Activity Guidelines for Adults with Spinal Cord Injury. Available at <http://www.sciactioncanada.ca/docs/guidelines/Physical-Activity-Guidelines-for-Adults-with-a-Spinal-Cord-Injury-Health-Care-Professional.pdf>. Accessed March 30, 2012.
34. Ter Woerds W, de Groot PC, van Kuppevelt DHJM, Hopman MTE. Passive leg movements and passive cycling do not alter arterial leg blood flow in subjects with spinal cord injury. *Phys Ther* 2006;86:636–45.
35. Svensson M, Siosteen A, Wetterqvist H, Sullivan L. Influence of physiotherapy on leg blood flow in patients with complete spinal cord injury lesions. *Physiother Theory Pract* 1995;11:97–107.
36. Muir GD, Steeves JD. Sensorimotor stimulation to improve locomotor recovery after spinal cord injury. *Trends Neurosci* 1997;20:72–7.
37. Van Londen A, Herwegh M, van der Zee CH, Daffertshofer A, Smit CA, Niezen A, Janssen TW. The effect of surface electric stimulation of the gluteal muscles on the interface pressure in seated people with spinal cord injury. *Arch Phys Med Rehabil* 2008;89:1724–32.
38. Bogie KM, Triolo RJ. Effects of regular use of neuromuscular electrical stimulation on tissue health. *J Rehabil Res Dev* 2003;40:469–75.
39. Lui QL, Nicholson GP, Knight SL, Chelvarajah R, Gall A, Middleton FRI, et al. Pressure changes under the ischial tuberosities of seated individuals during sacral nerve root stimulation. *J Rehabil Res Dev* 2006;43:209–18.
40. Bogie KM, Wang X, Triolo RJ. Long-term prevention of pressure ulcers in high-risk patients: a single case study of the use of gluteal neuromuscular electric stimulation. *Arch Phys Med Rehabil* 2006;87:585–91.

CONTENTS

PRINCIPLES	153
ASSESSMENT	153
THE INDIVIDUAL	153
Components of a comprehensive assessment	153
Re-evaluation of pressure and other forces	154
THE ULCER	155
WOUND INFECTION	156
Complications of wound infection	157
REASSESSMENT	158
EVIDENCE	159
CONCLUSIONS	159
REFERENCES	160

Principles

Assessment of both the pressure ulcer and the individual are crucial to determine the ulcer etiology and plan and evaluate treatment. Assessment includes reassessment of pressure ulcer risk factors; a comprehensive assessment of the individual, including equipment and behaviours; factors affecting pressure, friction, and shear; assessment of factors that may affect the success of the treatment plan; and a complete assessment of the ulcer.

A pressure ulcer may be a manifestation of underlying disease, and it represents a significant change in health status or physical functioning. The occurrence of a pressure ulcer in a person with spinal cord injury indicates the need for a thorough reassessment to uncover causative, contributing, and predisposing factors. This reassessment should include assessment of the individual and the ulcer.

The expertise required to help people with spinal cord injury and pressure ulcers is seldom available in general care provided through primary care physicians or community care services. The optimal approach to managing pressure ulcers in people with spinal cord injury is with an interprofessional team with dual expertise in wound care and spinal cord injury. Such a team has the skills to manage the complexities of pressure ulcer prevention and treatment in this population.



Speciality clinics or outreach services from specialized centres allow interprofessional team members to communicate more effectively, learn from each other's expertise, and assess and treat patients more efficiently.

Individuals who have a pressure ulcer are at greater risk of developing additional areas of skin breakdown.  **CHAPTER 1, *Pressure ulcer prevention and the interprofessional team, provides information about pressure ulcer risk factors.***

Assessment

THE INDIVIDUAL

Components of a comprehensive assessment

8.1: Interprofessional team assessment of the individual

Ensure that the interprofessional spinal cord injury team performs a prompt, comprehensive evaluation of a person with spinal cord injury who develops a pressure ulcer, including the following:









- Investigate underlying medical conditions
- Identify recent changes in physical or mental status
- Evaluate nutritional status
- Evaluate microclimate management
- Assess all support surfaces, lifts, and transfers
- Review pressure redistribution strategies, repositioning schedules, and skin checks
- Review posture and positioning in sitting and recumbency to identify changes and needs
- Review current preventive strategies

RECOMMENDATION LEVEL 1B



Assessment of the individual with a pressure ulcer has several objectives, including determining the etiology of the ulcer, the presence of pressure ulcer risk factors, any underlying disease processes, and contributory physical and psychological disorders.⁽⁸⁾ It is also important to assess factors that may affect the success of the treatment plan, such as the individual's lifestyle; available supports, resources, and personal care assistance; the individual's self-care abilities; and nutritional adequacy. Factors affecting pressure, friction, and shear include posture, positioning, transfers, methods of redistributing pressure, support surfaces, and equipment.  **APPENDIX 8B** *provides an example of a pressure management assessment tool.*

Where specific recommendations exist for assessing risk factors, or evidence supports one assessment tool over another, base the assessment on the recommendation or the evidence. For example:

- **Assessment of risk factors:** No objective risk assessment tool has been validated in people with spinal cord injury. The Waterlow, the Braden, and the Spinal Cord Injury Pressure Ulcer Scale (SCIPUS) may be the best options.^(1,2) The Braden tool has been used extensively, and the SCIPUS appears promising.  **CHAPTER 1**, *Pressure ulcer prevention and the interprofessional team, provides information on risk assessment tools.*
- **Assessment of nutrition:** Follow recommendations for assessment of nutritional status.  **CHAPTER 3**, *Body weight, nutrition, and hematologic and biochemical parameters of healing, provides recommendations for this assessment.*
- **Review of biochemical profile:** Analyze blood work profile, examining nutritional, biochemical, and hematologic markers that are known to affect healing.  **CHAPTER 3**, *Body weight, nutrition, and hematologic and biochemical parameters of healing, provides recommendations for this assessment.*
- **Assessment of depression:** Select a tool to screen for depression that is reliable in the spinal cord injury population or a measure that is supported by reliability and validity data.^(3,4)  **CHAPTER 2**, *Human factors affecting pressure ulcer prevention, discusses this topic.*
- **Assessment of pain:** The multidimensional McGill Pain Questionnaire has better sensitivity for assessing the dimensions of pain than a simpler pain assessment scale.⁽⁵⁾  **CHAPTER 2**, *Human factors affecting pressure ulcer prevention, contains additional information on pain.*
- **Assessment for psychological impairment and personality disorders:** These factors increase pressure ulcer risk.  **CHAPTER 2**, *Human factors affecting pressure ulcer prevention, discusses this topic.*
- **Assessment of individual ability to perform skin inspection and pressure-redistributing movements:** The Skin Management Needs Assessment Checklist (SMnac) has high internal consistency and sensitivity to change. It identifies specific problems and standardizes inputs, allowing measurement of the effect of interventions.⁽⁶⁾  **CHAPTER 2**, *Human factors affecting pressure ulcer prevention, discusses this topic.*
- **Vascular assessment:** For pressure ulcers on the legs, perform a vascular assessment that includes a clinical assessment, including pedal pulses, capillary refill, ankle/brachial pressure index, and toe pressure to rule out vascular compromise.⁽⁷⁾
- **Assessment of force and microclimate over 24 hours:** This complex issue involves a sitting and recumbent assessment, assessment of positioning and support surfaces, mobility, and pressure-redistributing movements.  **CHAPTER 4**, *Principles of pressure management, provides detailed information on this topic.*

Re-evaluation of pressure and other forces

It is important to assess the person actively: to look, evaluate, and verify.

- Support surfaces:
 - » Which surfaces allow pressure ulcer offloading?
 - » Can other surfaces be avoided until the ulcer heals?

- » Or can another surface be substituted?
- » Is a support surface a likely contributing factor to the pressure ulcer?
- » If support surfaces need to be upgraded, will it be possible to obtain the appropriate equipment (funding, specialized clinician to recommend changes)?
- » After ulcer healing, can the individual return to using the same equipment?
- » Will new equipment be indicated for long-term management and will funding be available to obtain it?
- Pressure management practices:
 - » Have they been effective?
 - » Did any unusual circumstances affect pressure ulcer development?
 - » Do practices need to change?
 - » Do repositioning schedules need to be upgraded?
 - » Will someone who was previously independent now need assistance?
 - » How feasible is a recommendation for increased repositioning?
 - » What pressure management practices need to change for long-term management?
- Functional management:
 - » Do the support surfaces used or functional management need to change temporarily to avoid weight-bearing on the pressure ulcer? For example, a person with a pressure ulcer on the coccyx who typically uses a commode for his or her bowel routine may need to consider performing the bowel routine in bed.
- Consultation:
 - » When are consultations with different healthcare professionals appropriate?
- Ulcer severity:
 - » Do support surface and pressure management recommendations differ based on ulcer severity?
 - » Are they the same?
- Monitoring ulcer status: Serial assessments can identify ulcer healing or worsening over time, which may have implications for adjustment of pressure management interventions.

THE ULCER

8.2: Assessing the pressure ulcer

Use a validated tool to assess the pressure ulcer, including the wound base, edges, and periwound skin

RECOMMENDATION LEVEL 1B

A complete and objective description of the pressure ulcer is necessary to develop the treatment plan and to evaluate healing over time.^(8,9) The following parameters should be assessed:

- **Location:** to determine any positioning restrictions
- **Size:** including length, width, depth, and area; and presence of tunnelling and sinuses, which may need to be assessed with imaging studies, such as sinography
- **Stage:**  **APPENDIX 3 provides the National Pressure Ulcer Advisory Panel updated staging system (2009).⁽⁷⁾**
- **Wound bed:** a healthy wound bed is clean and red
- **Eschar:** black indicates dried necrotic tissue, and yellow indicates fibrin slough
- **Granulation tissue:** beefy red and bumpy indicates healing



- **Epithelialization:** regrowth of epidermis across the surface of the pressure ulcer, pearly appearance
- **Wound margins:** assessment of undermining and rolling, which can impair healing
- **Exudate:** amount, colour, and consistency
- **Odour**
- **Periwound tissues:** Erythema, swelling, heat, and induration may indicate cellulitis; maceration due to wound exudate or incontinence indicates a potential for wound deterioration and enlargement.
- **Pain:** Severe pain may be associated with pressure ulcers.

 The following resources provide additional information on pressure ulcer assessment:

- Registered Nurses' Association of Ontario. *Nursing best practice guideline: Assessment & Management of Stage I to IV Pressure Ulcers 2011*. Available at <http://www.rnao.org/bestpractices>.
- Keast DH, Parslow N, Houghton PE, Norton L, Fraser C. *Best practice recommendations for the prevention and treatment of pressure ulcers: Update 2006*. *Wound Care Canada* 2006;4:31–43.

WOUND INFECTION

Although people with spinal cord injury have an increased risk of infection, no evidence shows that wound infections in people with spinal cord injury differ from those in people without spinal cord injury.



As a result, wound infections in people with spinal cord injury can be treated in the same way as infections occurring in pressure ulcers in the general population.^(9,10)

Biofilms produced by microorganisms protect bacteria, making them resistant to conventional therapy and to culture, and decreasing host defences and the effects of antimicrobials.⁽¹¹⁾ Bacteria protected by biofilms may be dormant for long periods of time and are frequently responsible for recurrent infection after repeated antibiotic therapy.

Recurrence of pressure ulcers at the initial ulcer site within a few months of healing may represent incomplete healing of the original ulcer as a result of persistent infection.⁽¹²⁾ Bates-Jensen et al performed a descriptive cohort study using available retrospective treatment data on 15 individuals from a prospective study of recurrent pressure ulcers in 24 individuals with 29 ulcers. Median time to recurrence was 13 weeks. Pressure ulcers developed at the same site in 15 (63%) people. Recurrent ulcers were full-thickness stage III (n=8, 28%) or stage IV (n=13, 45%) ulcers. The most common site of recurrence was the ischial tuberosities (n=17, 59%). Among individuals with available treatment data, infection treated with antibiotics was documented in 11 (73%) people.

Mylotte et al performed prospective surveillance for antibiotic-resistant organisms in 63 people with spinal cord injury during initial rehabilitation.⁽¹³⁾ Resistant organisms were isolated at admission in 27 (43%) people and were acquired by 36 (22%) people during hospitalization. The only factor predicting



8.3: Identify wound infection

- Evaluate the pressure ulcer for clinical signs of superficial or deep infection.
- Investigate for bone infection if infection persists or the wound fails to progress in the expected time frame.

RECOMMENDATION LEVEL III

Bacterial colonization is present in open wounds.⁽¹⁾ Clinicians can use the enablers NERDS and STONEES, which describe clinical signs and symptoms of infection, in differentiating between superficial and deep infection.⁽¹⁴⁾

The presence of at least three of the following indicates a high bacterial population in the superficial wound compartment (NERDS)⁽¹⁴⁾:

- Nonhealing
- Exudate increasing
- Red, friable granulation tissue
- Debris or dead cells on the wound surface
- Smell

Presence of at least three of the following indicates a high bacterial population in the deep and surrounding compartment of the wound (STONEES)⁽¹⁴⁾:

- Size increasing
- Temperature increasing
- Os: probing to exposed bone
- New or satellite wounds
- Erythema/edema
- Exudate increasing
- Smell

Culture is non-informative if done improperly. It is possible to obtain accurate results if exudate and debris are removed and the wound is properly cleaned before swabbing. The Levine method is used for swabbing the wound.⁽¹⁵⁾  **APPENDIX 6 details the Levine method for wound swab for culture and sensitivity.** The most accurate wound bed information requires punch biopsy, which is useful for ulcers not demonstrating healing within 2 weeks of treatment initiation but may not always be available.

Fever, vasomotor instability, and other signs of systemic sepsis can be associated with pressure ulcers; systemic signs require appropriate management.



Persistent bacteremia from pressure ulcer infection is associated with a high mortality rate.⁽¹⁶⁾

No simple noninvasive way to diagnose osteomyelitis has been identified.⁽¹⁶⁾ Careful debridement, including debridement of exposed infected bone and use of perioperative antibiotic therapy can prepare the wound for closure. Once the wound is stable and free of infection, surgical wound closure can be considered.  **CHAPTER 9, Pressure ulcer treatment, describes management of osteomyelitis and surgical treatment.**

Complications of wound infection

Hypergranulation tissue, also referred to as exuberant granulation, is a marker of wound infection.⁽⁸⁾ The transition between healthy, normal granulation tissue and hypergranulation is undefined, but it can be described as the time that epithelialization and healing stop.⁽¹⁷⁾ Some wound experts think the wound may be stalled in the proliferative phase, with an increased risk of infection. Factors triggering formation of hypergranulation include critical colonization or infection, excess moisture, friction or movement at the wound–skin interface, and foreign material.

Traditional treatments, such as silver nitrate or corticosteroid cream, are usually ineffective. Surgical debridement removes the tissue, but recurrence is common. Hypertonic saline or vapour-permeable foam dressings can reduce hypergranulation tissue, but neither addresses the inflammatory or infectious component.

A multifaceted intervention may most effectively deal with the various causes of hypergranulation. Widgerow and Leak proposed the following approach to managing hypergranulation⁽¹⁷⁾:

- Sharp debridement to remove excess tissue
- Silver alginate dressing to control bleeding and exudation and inhibit bacteria
- A secondary foam dressing to control excess exudate, provide compression, and prevent shear and friction at the interface between wound and skin
- Minor compression to secure dressings and prevent friction

This regimen can successfully manage hypergranulation tissue. Note: The study population was not specified.

Malignant transformation of chronic wounds, known as Marjolin's ulcer, can occur in a variety of wound types. Marjolin's ulcer is rare in pressure ulcers. A case report identified a rare cancer, verrucous carcinoma in the foot, that developed after only 3 years of ulcer chronicity.⁽¹⁸⁾ The ulcer was removed by wide excision. It is important to consider the possibility of malignant transformation in nonhealing ulcers, and to perform a biopsy if Marjolin's ulcer is considered a possibility.

Reassessment



8.4: Pressure ulcer monitoring

Monitor and assess the pressure ulcer consistently and regularly to determine the adequacy of the plan of care:

- Monitor the pressure ulcer at each dressing change.
- Review and document pressure ulcer status at least monthly and every time the condition of the pressure ulcer or the individual changes.
- Consider individual factors when evaluating the healing rate of pressure ulcers.

RECOMMENDATION LEVEL IV



8.5: Objective assessment of healing

Evaluate the progress of healing using an instrument or quantitative measure that has been shown responsive to change in wound status, such as acetate tracing, the Photographic Wound Assessment Tool (PWAT) or the Pressure Ulcer Scale for Healing (PUSH).

RECOMMENDATION LEVEL IB



8.6: Regular reassessment

Assess people who have experienced a pressure ulcer, through the interprofessional spinal cord injury team, every 12 to 24 months to evaluate posture, positioning, pressure redistribution strategies, microclimate factors (temperature and moisture), and equipment. Follow people experiencing continuing difficulties more frequently.

RECOMMENDATION LEVEL IV

EVIDENCE

The Bates-Jensen Wound Assessment Tool (BWAT), formerly known as the Pressure Sore Status Tool, is not recommended for monitoring healing. This well-recognized descriptive tool has excellent inter-rater reliability, and it is very useful when conducting an initial assessment of the wound. However, some studies found the BWAT did not detect differences between groups or over time, even when outcomes differed.⁽¹⁹⁾

Both the Photographic Wound Assessment Tool (PWAT) and the Pressure Ulcer Scale for Healing (PUSH) have been used to detect healing of pressure ulcers in people with spinal cord injury.^(19,20) The PWAT has been shown to have excellent reliability and good concurrent validity with other well-established measures of healing.⁽²¹⁾

Healing is generally slower in people with spinal cord injury than in other individuals with pressure ulcers. Expected healing time in the population with spinal cord injury varies, depending on the individual situation, including age, comorbidities, nutritional status, and other factors. Clinical knowledge, experience, and judgment determine when the treatment plan should be altered. In general, after debridement, measurable healing is expected on a monthly basis. Biopsy for tissue culture and histology may be considered if no improvement is seen. A risk exists of malignant transformation of chronic ulcers (> 10 years) into Marjolin's ulcer.

CONCLUSIONS

Assessment after development of a pressure ulcer involves a thorough evaluation of the individual and the ulcer. This assessment is designed to determine the etiology of the ulcer and any contributing factors, to ensure the following:

- Specific ulcer treatment and preventive interventions are appropriately targeted.
- Causative factors are eliminated.
- The individual has the psychological and physical resources to support the success of the treatment plan.
- The risk of another ulcer is significantly reduced.

REFERENCES

1. Balzer K, Pohl C, Dassen T, Halfens R. The Norton, Waterlow, Braden, and Care Dependency scales: comparing their validity when identifying patients' pressure sore risk. *J Wound Ostomy Continence Nurs* 2007;34:389–98.
2. Wellard S, Lo SK. Comparing Norton, Braden and Waterlow risk assessment scales for pressure ulcers in spinal cord injuries. *Contemp Nurse* 2000;9:155–60. Asses
3. Dorsett P, Geraghty T. Depression and adjustment after spinal cord injury: a three-year longitudinal study. *Top Spinal Cord Inj Rehabil* 2004;9:43–56.
4. Kalpakjian C, Bombardier C, Schomer K, Brown P, Johnson K. Measuring depression in persons with spinal cord injury: a systematic review. *J Spinal Cord Med* 2008;31:47–65.
5. Roth RS, Lowery JC, Hamill JB. Assessing persistent pain and its relation to affective distress, depressive symptoms, and pain catastrophizing in patients with chronic wounds. *Am J Phys Med Rehabil* 2004;83:827–34.
6. Berry C, Kennedy P, Hindson LM. Internal consistency and responsiveness of the skin management needs assessment checklist post-spinal cord injury. *J Spinal Cord Med* 2004;27:63–71.
7. European Pressure Ulcer Advisory Panel and National Pressure Ulcer Advisory Panel. Development of an international pressure ulcer classification system. Treatment of pressure ulcers: quick reference guide. Washington, DC: National Pressure Ulcer Advisory Panel; 2009. Available at <http://www.npuap.org>. Accessed June 25, 2011.
8. Consortium for Spinal Cord Medicine Clinical Practice Guidelines. Pressure ulcer prevention and treatment following spinal cord injury: a clinical practice guideline for health-care professionals. *J Spinal Cord Med* 2001;24(Suppl 1):S40–101.
9. Registered Nurses' Association of Ontario. Nursing best practice guideline: Assessment & Management of Stage I to IV Pressure Ulcers 2011. Available at <http://www.rnao.org/bestpractices>. Accessed June 25, 2011.
10. World Union of Wound Healing Societies. Principles of best practice: wound infection in clinical practice. An international consensus. London: MEP Ltd; 2008. Available from <http://www.mepltd.co.uk>. Accessed June 25, 2011.
11. Saye DE. Recurring and antimicrobial-resistant infections: considering the potential role of biofilms in clinical practice. *Ostomy Wound Manage* 2007;53:46–57.
12. Bates-Jensen, BM, Guihan M, Garber, SL, Chin AS, Stephen PM. Characteristics of recurrent pressure ulcers in veterans with spinal cord injury. *J Spinal Cord Med* 2009;32:34–42.
13. Mylotte JM, Kahler L, Graham R, Young L, Goodnough S. Prospective surveillance for antibiotic resistant organisms in patients with spinal cord injury admitted to an acute rehabilitation unit. *Am J Infect Contr* 2000;28:291–7.
14. Woo KY, Sibbald RG. A cross sectional validation study of using NERDS AND STONEES to assess bacterial burden. *Ostomy Wound Manage* 2009;55:40–8.
15. Southwest Community Care Access Centre. Levine method for wound swab for culture & sensitivity. Southwest Regional Wound Care Toolkit. Available at <http://www.ccac-ont.ca/Upload/sw/General/WoundCare/SWCCACWoundManagementProgram.pdf>. Accessed September 16, 2011.
16. Keast DH, Parslow N, Houghton PE, Norton L, Fraser C. Best practice recommendations for the prevention and treatment of pressure ulcers: update 2006. *Wound Care Canada* 2006;4:31–43.
17. Widgerow AD, Leak K. Hypergranulation tissue: evolution, control and potential elimination. *Wound Healing Southern Africa* 2010;3:7–9.
18. Lee MY, Shin JC, Park CI, Rha DW, Sastry TK. Verrucous carcinoma of the foot from chronic pressure ulcer. *Spinal Cord* 2004;42:431–4.
19. Houghton, PE, Campbell KE, Fraser CH, Harris C, Keast DH, Potter PJ, et al. Electrical stimulation therapy increases rate of healing of pressure ulcers in community dwelling people with spinal cord injury. *Arch Phys Med Rehabil* 2010;91:669–78.
20. Hon J, Lagden K, McLaren AM, Orr L, O'Sullivan D. A prospective, multi-centre study to validate use of pressure ulcer scale for healing (PUSH,©) in patients with diabetic, venous, and pressure ulcers. *Ostomy Wound Manage* 2010;56:26–36.
21. Houghton PE, Campbell KE. Chapter 42: Therapeutic modalities in the treatment of chronic recalcitrant wounds. In: Krasner GT, Rodheaver GT, Sibbald RG, Woo KY, eds. *Chronic Wound Care: A Clinical Source Book for Health Care Professionals*. 5th Edition. Wayne, PA: Health Management Publications Inc.; 2012.

CONTENTS

PRINCIPLES	163
Interprofessional team	163
Pressure ulcer causes and contributing factors	164
Bed rest and pressure ulcer healing	164
PRESSURE MANAGEMENT	165
Need for comprehensive reassessment	165
Need for short-term rehabilitation	166
Sitting Schedules and Positioning	166
Support surfaces	166
Selection of recumbent support surfaces	166
Assessment of sitting support surfaces and equipment	167
NONSURGICAL TREATMENT	168
WOUND CARE	168
RNAO recommendations	168
Cleansing and antiseptics	169
Debridement	169
Dressings	169
Wound infection	170
ADJUNCTIVE THERAPY	170
Electrical stimulation	170
Evidence	170
Other adjunctive therapies	171
Electromagnetic energy	172
Ultraviolet-C light	172
Noncontact nonthermal acoustic pressure therapy	172
Topical oxygen	172
Maggot therapy	172
Topical recombinant growth factors	172
Recombinant human erythropoietin	173
Anabolic steroids	173
Activated factor XIII	173
Tension therapy	173
Hyperbaric oxygen	174
Adjunctive therapies not recommended for treatment of pressure ulcers in people with spinal cord injury	174
Ultrasound	174
Negative pressure wound therapy	174
Lasers	174
Topical phenytoin	174

SURGICAL TREATMENT	175
PRINCIPLES	175
Interprofessional team	175
Criteria for surgical closure of a pressure ulcer	175
PREOPERATIVE CONSIDERATIONS	177
Infection	177
Nutrition	177
Incontinence	178
Spasticity and contractures	178
Comorbidities	179
Previous pressure ulcer surgery	179
Smoking	179
Osteomyelitis	179
Urinary tract infection	180
Heterotopic ossification	180
SURGICAL PROCEDURES	180
Debridement	180
Flap surgery	181
Ischial pressure ulcer repair	182
Sacral pressure ulcer repair	182
Perineal pressure ulcer repair	183
Olecranon pressure ulcer repair	183
Repair of complex back wounds	183
Amputation and salvage surgery	184
POSTOPERATIVE MANAGEMENT	185
Surgical complications	185
CONCLUSIONS	186
REFERENCES	187

Principles

A comprehensive treatment plan for a pressure ulcer includes strategies to address the etiology of the pressure ulcer, such as pressure management, specific wound care, adjunctive therapies to support healing as necessary, surgery for complex or deep stage III and IV ulcers, management of complications, and educational and nutritional interventions.

Within the wound care field, a standardized approach to wound bed preparation is a well-recognized conceptual framework that directs wound management and treatment strategies. This approach involves three basic treatment principles: the person, the underlying cause, and the wound.⁽¹⁾ The wound cannot be considered in isolation. Without considering individual values, motivation, and limitations, treatment will have minimal success. Similarly, comprehensive wound treatment requires clinicians to recognize underlying causative factors. In the case of pressure ulcers, this includes sources of external forces such as pressure, friction, and shear, and any nutritional deficiencies. Local wound care involves addressing wound bioburden and potential infective agents, controlling wound moisture, and removing foreign bodies and devitalized tissues with appropriate debridement techniques. The local wound environment of a pressure ulcer in a person with spinal cord injury does not differ substantially from that of any other person. This section contains a brief overview of wound care.

-  Detailed information about best practices in wound care can be found in various documents, including the following:
- Registered Nurses' Association of Ontario. *Nursing Best Practice Guideline: Assessment & Management of Stage I to IV Pressure Ulcers 2011*. Available at <http://www.rnao.org/bestpractices>.
 - Keast DH, Parslow N, Houghton PE, Norton L, Fraser C. *Best practice recommendations for the prevention and treatment of pressure ulcers: update 2006*. *Wound Care Canada* 2006;4:31–43.
 - European Pressure Ulcer Advisory Panel and National Pressure Ulcer Advisory Panel. *Treatment of pressure ulcers: quick reference guide*. Washington, DC: National Pressure Ulcer Advisory Panel; 2009. Available at http://www.epuap.org/guidelines/Final_Quick_Treatment.pdf. Accessed June 1, 2011.
 - Sibbald R Gary, Goodman L, Woo KY, Krasner DL, Smart H, Tariq G, et al. *Special considerations in wound bed preparation 2011: an update*. *Adv Skin Wound Care* 2011;24:415–35.

These guidelines and other best practices recommended for different types of chronic wounds, such as diabetic foot ulcers and venous leg ulcers, consistently advocate developing and implementing an interprofessional wound care team. The multifaceted care delivered by a team comprised of several different healthcare professionals with complementary skills and with the person at the centre is considered the optimal approach to managing complex clinical situations. A team approach to pressure ulcer treatment that includes collaboration with the person with spinal cord injury improves satisfaction with care and motivation to adhere to recommended interventions.

Interprofessional team

9.1: Interprofessional team for pressure ulcer treatment

Ensure timely referral to the interprofessional spinal cord injury team in treating pressure ulcers in this population.

RECOMMENDATION LEVEL IV

The optimal approach to managing pressure ulcers in people with spinal cord injury is with an interprofessional team with dual expertise in wound care and spinal cord injury. Such a team has the skills to manage the complexities of pressure ulcer prevention and treatment in this population.  **CHAPTER 1, *Pressure ulcer prevention and the interprofessional team*, includes a discussion of the team approach.**



Although interprofessional wound care teams are strongly recommended, no clinical trial reported to date demonstrates better clinical outcomes with a team approach compared with current practice. Indirect evidence exists within clinical trials that have incorporated interprofessional teams to provide standard wound care protocols as part of the overall treatment program for people with spinal cord injury and pressure ulcers.⁽²⁾

Collaborative interprofessional practice has been recommended for the management of other common health conditions, such as diabetic foot complications in people with diabetes.⁽³⁾ These specialized teams have been shown to improve patient outcomes.^(4,5) Clinical challenges encountered in people with spinal cord injury and pressure ulcers can best be addressed by such a team contributing to the management of the person and the wound. *Research is needed to document clinical outcomes achieved with input from an interprofessional pressure management and skin care team to manage pressure ulcers in people with spinal cord injury.*





Pressure ulcer causes and contributing factors

It is critical to evaluate sources of excessive or prolonged pressure, friction, and shear, and problems with local skin temperature and moisture to make suitable alterations in equipment and daily activities to maximize function while minimizing trauma to the affected area.

 *The following chapters contain information relevant to management of force and microclimate in a person with a pressure ulcer:*

- **CHAPTER 4:** *Principles of pressure management*
- **CHAPTER 5:** *Beds, mattresses, and recumbent positioning*
- **CHAPTER 6:** *Wheelchairs and other seating*
- **CHAPTER 7:** *Mobility, activity, and conditioning*

Poor nutritional status can be not only a risk factor for, but also a complication of, a pressure ulcer, as significant amounts of protein and fluid can be lost in the pressure ulcer exudate, creating or aggravating malnutrition and hypoalbuminemia.⁽⁵⁾ Induction of chronic inflammation by pressure ulcers increases metabolism, resulting in unplanned weight loss. Chronic pressure ulcers may lead to anemia of chronic disease.  **CHAPTER 3, *Body weight, nutrition, and hematologic and biochemical parameters of healing,* reviews the impact of nutrition on pressure ulcers.**

Psychosocial issues may contribute to skin breakdown or interfere with pressure ulcer healing. Depression, anxiety, and other psychological disorders are known to impair quality of life and interfere with optimal healing. Caregiver burden and financial concerns and other sources of personal stress can also drastically affect the health of the person and limit treatment success. A person's knowledge and beliefs about managing pressure, pressure management practices, lifestyle, and self-management skills also significantly affect pressure ulcer risk, occurrence, and the success of pressure ulcer treatment.  **CHAPTER 2, *Human factors affecting pressure ulcer prevention,* provides information about the impact of psychological factors on pressure ulcer risk and healing.**

Bed rest and pressure ulcer healing



Evidence does not support full-time bed rest to treat pressure ulcers in people with spinal cord injury.⁽⁶⁾ A modified sitting protocol with intermittent bed rest may be useful.

Although the ideal environment for healing is one in which a pressure ulcer is free of pressure, the potential benefit of bed rest in providing this pressure-free wound environment must be weighed against the negative physical, social, psychological, and financial consequences. Being able to use their wheelchair and participate in life is of great importance to people with spinal cord injury.

The alternative to bed rest is a comprehensive assessment of potential causative factors and implementation of effective 24-hour interface pressure management. Technological advances now make it possible to offload a pressure ulcer in a

seated person, using high-immersion and offloading cushions. One problem with implementing this approach, however, may be lack of expertise or appropriate equipment in some care settings.

A certain amount of bed rest is always required after surgical closure of sitting-acquired pressure ulcers (see Postoperative management (Page page 185)).⁽⁶⁾ Bed rest may also be indicated when factors that can disrupt wound healing, such as positioning and transfers, are associated with seated positions. Shear forces during transfers that affect the reconstruction can cause wound disruption. Hip flexion and thigh positioning in the seated position can produce tension on the wound closure and lead to wound disruption.  **CHAPTER 5, *Beds, mattresses, and recumbent positioning, includes a discussion about bed rest.***

Pressure management

Need for comprehensive reassessment



The occurrence of a pressure ulcer in a person with spinal cord injury indicates the need for a thorough reassessment to uncover causative, contributing, and predisposing factors.

The objectives of reassessment are the following:

- Ensure effective treatment of the existing ulcer
- Ensure identification and management of all risk factors to prevent development of new pressure ulcers in the same location and other locations, both during treatment and in the future.

This evaluation should review:

- Existing medical conditions and investigation to identify any new conditions
- Nutritional status
- Skin health practices:
 - » Contenance
 - » Repositioning schedules and skin checks
- Posture and positioning strategies in recumbency and sitting: many pressure ulcer risk factors are related to wheelchair use and positioning, and it is important to review all support surfaces and the environment
- Mobility and ambulation:
 - » Gross motor skills used in transfers and other pressure-redistribution strategies
 - » Daily activities, level of conditioning, and participation in exercise
- Psychosocial issues and lifestyle choices

A comprehensive assessment that includes the issues above requires a skilled and experienced interprofessional team.

 **CHAPTER 1, *Pressure ulcer prevention and the interprofessional team, provides recommendations about the importance of assessing risk factors and additional information about the interprofessional team.***

It is important to reassess support surfaces, positioning, repositioning schedules, and functional management during pressure ulcer treatment.⁽⁷⁾ If flap surgery is required, additional consultations may be needed to determine appropriate seated and recumbent support surfaces, positioning strategies, repositioning schedules, and functional management before and after surgery. After the pressure ulcer heals, equipment, support surfaces, and pressure management practices need reassessment and may need adjustment for long-term prevention.  **CHAPTER 4, *Principles of pressure management, contains information on reassessment.***

Need for short-term rehabilitation

People with spinal cord injury who have experienced a pressure ulcer may require specific interventions to regain physical conditioning and implement changes in self-care and prevention strategies to decrease the risk of recurrence. These interventions may occur in the community if frequent access to skilled rehabilitation specialists are available through out patient services, or may require a short admission to a rehabilitation facility or program. Treatment and prevention strategies need to include an individualized follow-up schedule with the interprofessional pressure management team. People experiencing continuing difficulties should be followed until the pressure ulcer heals.  **CHAPTER 1, Pressure ulcer prevention and the interprofessional team, provides evidence for early admission to specialized units with interprofessional spinal cord injury teams.**

Sitting Schedules and Positioning



9.2: Sitting schedules for pressure ulcer treatment

Evaluate the individual's postural alignment, weight distribution, balance, stability, and pressure-redistributing capability to establish an appropriate sitting schedule.

RECOMMENDATION LEVEL IV

Implementing effective 24-hour offloading of pressure on the ulcer can prevent the need for full-time bed rest.⁽⁶⁾ A modified sitting protocol, starting with brief periods of sitting, and intermittent bed rest may be useful in this context.

 **APPENDIX 5 provides an example of a graduated sitting protocol.**

Similarly, advanced wheelchair cushions and tilt-and-recline wheelchairs may be effective in offloading the ulcer. An important part of treatment is re-educating the person about recommended positioning, repositioning schedules, support surface use, transfer techniques, and pressure-redistribution movements.

Positioning and repositioning schedules for pressure ulcer treatment may limit or eliminate use of certain positions. As a result, it is important to monitor all areas of the body vulnerable to pressure to ensure new pressure ulcers do not develop. Upgrading repositioning schedules to every 15 minutes may affect care hours, independence, and practical aspects of managing more frequent repositioning  **CHAPTER 5, Beds, mattresses, and recumbent positioning, includes recommendations related to turning schedules and strategies to avoid injury during repositioning.**

The frequency of skin inspection after each positioning interval increases during treatment of pressure ulcers to monitor the skin response to repositioning schedule changes and upgraded support surfaces.⁽⁷⁾  **CHAPTER 2, Human factors affecting pressure ulcer prevention, includes additional information about skin inspection.**

Support surfaces

SELECTION OF RECUMBENT SUPPORT SURFACES



9.3: Beds and mattresses

Consider replacing the recumbent support surface with one that provides better pressure redistribution, offloading capabilities, shear reduction, and microclimate control for individuals who:

- Cannot be positioned off the ulcer
- Have pressure ulcers on at least two turning surfaces
- Fail to heal or demonstrate ulcer deterioration despite appropriate comprehensive care
- Have a high risk of developing additional ulcers
- Bottom out on the existing support surface

RECOMMENDATION LEVEL IV

The selection of the most appropriate recumbent support surface needs to be tailored to the individual's unique needs and current living situation. The amount of pressure redistribution must be carefully balanced with the individual's functional independence, personal preferences, and lifestyle choices.



It is important to re-evaluate the suitability of the recumbent support surface for pressure ulcer treatment if the person's medical condition changes.

Reactive support surfaces are appropriate for individuals who can be positioned without weight bearing on an ulcer or without bottoming out on the support surface.⁽⁸⁾ Active support surfaces are appropriate if:

- The individual cannot be positioned without pressure on an ulcer
- A reactive support surface bottoms out
- There is no evidence of ulcer healing
- New ulcers develop on a reactive support surface

Low- and high-air-loss (air-fluidized) beds are used to treat pressure ulcers if pressure ulcers are present on multiple turning surfaces, microclimate control is compromised, or deep tissue injury is present.⁽⁸⁾



- **CHAPTER 5, Beds, mattresses, and recumbent positioning, provides additional detail about use of positioning and support surfaces to manage pressure.**
- **APPENDIX 4 provides information about support surfaces and tools for recumbent support surface selection.**
- *The European Pressure Ulcer Advisory Panel and National Pressure Ulcer Advisory Panel. Treatment of pressure ulcers: quick reference guide. Washington, DC: National Pressure Ulcer Advisory Panel; 2009, is available at http://www.epuap.org/guidelines/Final_Quick_Treatment.pdf. It provides recommendations for recumbent support surfaces for the general population*

ASSESSMENT OF SITTING SUPPORT SURFACES AND EQUIPMENT

9.4: Assess support surfaces for treatment

Assess the suitability of existing sitting support surfaces for treatment in a person with a pressure ulcer.

Evaluate the current sitting surface or cushion to determine if an alternative choice would better meet the person's needs during treatment of the ulcer.

RECOMMENDATION LEVEL IV

Not all pressure ulcers in the buttock region are caused by sitting or wheelchair use. A clinician with advanced training and experience in prescribing seating equipment should evaluate the person with a pressure ulcer and all surfaces encountered throughout his or her day, recommend appropriate equipment, expedite access to the equipment, and recommend duration of use.

A sitting support surface that may have contributed to ulcer development must be changed, either permanently or until healing is complete. A pressure ulcer attributable to prolonged sitting that occurs in an individual who cannot alter wheelchair time due to lifestyle may necessitate an upgraded offloading support surface to prevent worsening until a more appropriate management approach can be implemented.

A randomized controlled study compared healing of stage II and III pressure ulcers in people using an individually adjusted automated seat providing cyclic pressure redistribution and in people using a standard wheelchair cushion.⁽⁹⁾ Regular assessment of the wound using the Pressure Ulcer Scale for Healing (PUSH) and digital photography over the 30-day study found the cyclic pressure relief group had attained a significantly greater percentage in their healing and



PUSH scores (45.0 ± 21.0 , 29.9 ± 24.6 , both $p < .003$) than the standard seating group (10.2 ± 34.9 , 5.8 ± 9.2). This approach can accelerate wound healing without compromising independence, mobility, or function.



- **CHAPTER 4**, *Principles of pressure management*, discusses regular reassessment of seating systems.
- Regan M, Teasell RW, Keast D, Aubut JL, Foulon BL, Mehta S. *Pressure Ulcers Following Spinal Cord Injury*. In: Eng JJ, Teasell RW, Miller WC, Wolfe DL, Townson AF, Hsieh JTC, Connolly SJ, Mehta S, Sakakibara BM, eds. *Spinal Cord Injury Rehabilitation Evidence*. Version 3.0: 2010 is available at <http://www.scireproject.com/rehabilitation-evidence/pressure-ulcers>. It contains information on research on interface pressures during sitting.

Sitting support surfaces must be carefully managed pre- and postoperatively in individuals who are undergoing surgery to close sitting-acquired pressure ulcers. A graduated sitting protocol must be implemented to avoid prolonged bed rest. (see Postoperative management Pag page 185).

Bowel and bladder management programs need to be reviewed and may need to change during pressure ulcer healing to prevent further pressure damage. For example, use of a commode or toilet may need to be replaced by a bowel routine managed temporarily in bed. Alternatively, the commode may need to be changed to a tilt or padded commode. It is also important to review bowel routines that require an extended period of time (> 1 hour) sitting on the toilet or commode. Inpatient or outpatient retraining or reconditioning to improve strength, balance, and transfer techniques may be required before resuming a previous routine. If the commode or the routine was a factor in pressure ulcer development, the equipment and process require reassessment to prevent recurrence.

In the presence of a pressure ulcer, showering is preferred to bathing. It is also important to avoid prolonged skin exposure to unpadded shower chair surfaces. Ensure that the uncovered skin is protected from excess trauma, friction, and shear during transfers onto and off shower surfaces. Bed bathing should be used only if regular showering has been assessed and deemed unsafe or potentially injurious to the patient (e.g., if the person is medically unstable).

Nonsurgical treatment

WOUND CARE



The local wound environment of pressure ulcers in people with spinal cord injury is similar to that in other populations and requires similar treatment approaches.

Standard local wound care principles are currently used to treat pressure ulcers in people with spinal cord injury. Best practice approaches for wound care are explained in general pressure ulcer treatment guidelines.^(7,8-11) *Registered Nurses' Association of Ontario. Nursing Best Practice Guideline: Assessment & Management of Stage I to IV Pressure Ulcers 2011. Available at <http://www.rnao.org/bestpractices>; this document provides additional information about treatment of pressure ulcers and a comprehensive approach to local wound care for this type of ulcer, and summarizes current research evidence supporting recommended clinical practice.*

RNAO recommendations

Key recommendations for wound bed preparation from the Registered Nurses' Association of Ontario (RNAO) guidelines are summarized here.⁽⁷⁾

CLEANSING AND ANTISEPTICS

- Cleanse pressure ulcers at each dressing change with a generous volume of sterile, tissue-friendly irrigant at a pressure that does not damage granulation tissue.
- Consider using antiseptic agents when the bacterial burden is of greater concern than stimulating wound healing. High-risk situations: prevention of postoperative infection after flap surgery or spinal stabilization, to prevent recurrence, is essential.

DEBRIDEMENT

- Ensure only qualified personnel debride devitalized tissue from healable pressure ulcers, using a method appropriate to the ulcer status, individual clinical condition, and treatment goals. Review risks, precautions, and contraindications for debridement and be ready to manage all potential outcomes.
- Do not debride intact, stable, dry, adherent eschar on the heels unless signs of infection are present.
- Factors affecting choice of debridement method include individual consent, pain, speed, tissue selectivity, exudates, infection, and cost.  *Registered Nurses' Association of Ontario. Nursing Best Practice Guideline: Assessment & Management of Stage I to IV Pressure Ulcers 2011. Available at <http://www.rnao.org/bestpractices>; this document provides descriptions of different types of wound debridement.*⁽⁷⁾

DRESSINGS

9.5: Dressings

Select a dressing(s) that provides the optimal moisture level to the wound base of superficial pressures ulcers. Ensure the dressing meets the needs of the individual and is modified as individual goals and/or wound status change. Avoid using daily dressing changes if at all possible by using absorbent dressings that manage exudate and odour and remain in place for as long as possible.

RECOMMENDATION LEVEL 1B

The RNAO recommends that the dressing selected

- Keeps the ulcer bed continuously moist and the surrounding intact skin dry; this does not apply to uninfected heels
- Controls exudate but does not desiccate the ulcer bed or macerate surrounding tissue
- Provides moisture to the base of superficial pressure ulcers; hydrocolloid or hydrogel dressings may promote faster wound closure
- Provides thermal insulation and wound temperature stability
- Protects the wound from microbial contamination
- Maintains its integrity and does not leave fibres or foreign substances in the wound
- Does not cause wound bed trauma on removal
- Meets the following criteria: simple handling, economical in cost and time, promotes (or does not slow) wound healing, acceptable to the person with the pressure ulcer

Dressings that provide wound moisture have been used for pressure ulcers in people with spinal cord injury. Hydrocolloids are the dressing of choice for many clinicians treating superficial stage II pressure ulcers. Three clinical studies, one of which was well designed,⁽¹²⁾ reported improved healing rates of pressure ulcers treated with moisture-retentive, semi-occlusive, interactive, advanced dressings (hydrocolloid or hydrogel).⁽¹²⁻¹⁴⁾ Although no research suggests one dressing performs better than another, the appropriate use of advanced dressings may improve patient comfort, reduce the frequency of dressing changes, and be more cost-effective. A dressing with a smooth top layer may assist in decreasing friction and shear with movement at the wound site. Dressings labelled with a radiopaque marker are useful in individuals with sinus tracts, to ensure dressings can be located when they are deep in a sinus.



Perform dressing changes on a specific schedule based on assessment of the individual, the ulcer, the condition of the dressing, and clinical judgment. Loosely fill pressure ulcer cavities with dressing material to avoid dead space; avoid over-packing the ulcer. Monitor dressings near the anus, and consider use of special sacral shaped dressings.

Wound infection



9.6: Consider antimicrobial dressings

Consider the use of antimicrobial dressings if signs of infection are present.

RECOMMENDATION LEVEL IV



Wound infections in people with spinal cord injury and pressure ulcer are treated in the same way as wound infections in the general population.

Antimicrobial dressings may be an appropriate choice for ulcers in areas with a high risk of contamination.⁽¹⁰⁾
CHAPTER 8, *Assessment after development of a pressure ulcer, provides information about evaluating infection.*

ADJUNCTIVE THERAPY

Electrical stimulation



9.7: Electrical stimulation to speed closure of pressure ulcers

Use electrical stimulation combined with standard wound care interventions to promote closure of stage III or IV pressure ulcers.

RECOMMENDATION LEVEL IA

EVIDENCE

In a systematic review performed by Regan et al⁽¹⁵⁾ in Spinal Cord Injury Rehabilitation Evidence (SCIRE), five small clinical studies, including three randomized controlled clinical studies⁽¹⁶⁻¹⁸⁾, examined the effects of various electrical stimulation protocols on healing rates of pressure ulcers in a spinal cord injury population. Based on their review of the evidence, they concluded “there is level 1 evidence from two randomized controlled trials to support the use of electrical stimulation to accelerate the healing rate of stage III/IV pressure ulcers....”⁽¹⁵⁾ Since that time, five more controlled clinical trials have evaluated the impact of electrical stimulation on accelerating healing of pressure ulcers in people with spinal cord injury.^(2,19-22)

Barczak et al performed a randomized controlled trial (N=33) on the effect of adding electrical stimulation to standard wound care to treat pressure ulcers in people with paraplegia.⁽¹⁹⁾ Standard therapy was used for 17 people and standard therapy plus electrical stimulation was used for 16 more. After 4 weeks' treatment, the wound healing rate was 73% greater in individuals who received electrical therapy ($p = .028$). At that time, surgical closure was used for 13 of 17 ulcers in the standard group and 14 of 16 ulcers in the stimulation group. The remaining ulcers were left to heal by secondary intention. The complication rate was high and comparable in both groups. Twelve weeks after surgery, 13 ulcers in the standard therapy group and all 16 ulcers in the electrical stimulation therapy group had healed completely. The difference was significant ($p = .041$).

Jercinovic et al performed a randomized controlled trial of low-frequency pulsed current in 73 people with spinal cord injury who had a total of 109 pressure ulcers.⁽²⁰⁾ Participants were treated with conventional therapy or conventional

therapy plus stimulation for 4 weeks, after which time those in the conventional group could cross over to electrical stimulation. The ulcer healing rate was significantly higher in the stimulation group ($p = .006$). Analysis of the group who crossed over to stimulation found the healing rate improved in 19 out of 20 participants ($p = .001$).

Houghton et al performed a single-blind, parallel-group, randomized, controlled clinical trial to investigate whether incorporating electric stimulation into community-based wound care could speed the healing rate of pressure ulcers in people with spinal cord injury.⁽²⁾ The wound care program provided interprofessional, customized wound treatment that included pressure management. Participants ($N=34$) with stage II to IV ulcers were stratified by ulcer severity and duration and randomized to standard therapy or standard therapy plus high-voltage pulsed current. At the end of the 3-month intervention, wound surface area decreased $70 \pm 25\%$ in the electrical stimulation group, compared with $36 \pm 61\%$ in the standard therapy group ($p = .048$). The proportion of stage III, IV, or unstageable ulcers in which wound surface area improved $\geq 50\%$ was significantly higher in the stimulation than in the standard group ($p = .02$). Wound appearance also improved in the stimulation but not in the standard therapy group.

Adunsky and Ohry treated 63 patients at a geriatrics and rehabilitation centre, including individuals with paraplegia, with a small device placed around the wound that delivered low levels of direct electrical current.⁽²²⁾ Active and placebo treatments were delivered as part of the dressing protocol for 8 weeks, and wound size and closure rates were recorded at 57 days, when treatment stopped, and at 147 days, 3 months after treatment stopped. The authors reported no difference between the groups in rates of complete wound closure or time needed to achieve complete closure.

Ahmad et al performed a study to determine the optimal duration of high-voltage pulsed galvanic current in treating chronic pressure ulcers in 60 people with spinal cord injury.⁽²³⁾ Participants were randomly divided into three treatment groups and a control group. Individuals in the treatment groups received 45, 60, or 120 minutes' treatment daily for 5 weeks. Wound surface area decreased significantly in all treatment groups at 3 and 5 weeks compared with baseline and in the 60- and 120-minute groups compared with the 45-minute and control groups ($p < .001$ for all).

A meta-analysis compiled results from several controlled clinical trials and produced an overall effect on healing rate and number of closed wounds that significantly favoured electrical stimulation for the treatment of pressure ulcers.⁽²⁴⁾ Five of the seven studies compiled in this meta-analysis specifically studied a spinal cord population, and all but one of them⁽²¹⁾ reported accelerated healing and improved wound closure rates in pressure ulcers treated with electrical stimulation plus standard care.

Other adjunctive therapies

9.8: Other adjunctive therapies for nonsurgical treatment of pressure ulcers

Consider adding the following adjunctive therapies to a standard wound care program to speed healing of stage II, III, or IV pressure ulcers.

	RECOMMENDATION LEVEL
■ Electromagnetic energy	Ib
■ Ultraviolet-C light	Ib
■ Noncontact nonthermal acoustic therapy	III
■ Topical oxygen	III
■ Maggot therapy	III
■ Topical recombinant growth factors	III
■ Recombinant erythropoietin	III
■ Anabolic steroids	III
■ Activated factor XIII	III
■ Tension therapy	IV
■ Hyperbaric oxygen	IV



ELECTROMAGNETIC ENERGY

Many researchers feel that cellular and physiologic mechanisms of electromagnetic therapy are similar to those of electrical stimulation therapy.⁽²⁵⁾ Previously, one controlled clinical trial had reported a significant difference between healing of pressure ulcers treated with or without pulsed, high-frequency, high peak-power electromagnetic energy.⁽²⁴⁾ No new studies, however, are available to clarify the role of electromagnetic energy in promoting healing of pressure ulcers in people with spinal cord injury. This recommendation is based on limited evidence. Newer technology, producing lower energy pulses, has not been evaluated in wound healing.

ULTRAVIOLET-C LIGHT

Nussbaum et al performed a double-blind, randomized, placebo-controlled trial of the effects of ultraviolet-C (UVC) light on healing stage II to IV pelvic or leg pressure ulcers in people with spinal cord injury.⁽²⁷⁾ Participants were stratified by wound location. Treatment was given three times weekly until wound closure, with UVC dosage based on ulcer depth and appearance. Endpoints were weekly healing rate, wound size reduction, and weeks to ulcer closure. Of the 44 participants with a total of 58 ulcers who began the study, 26 people with 32 ulcers left the study before wound closure. The median weekly healing rate for stage II ulcers was 30% for UVC and 5.8% for placebo (achieved significance level [ASL] = .063), substantially greater than the clinical minimally important difference, with stage II pelvic ulcers benefitting the most. Between-group healing rates were similar for stage III and IV pelvic ulcers, with closure averaging 6 weeks with UVC and 9 weeks with placebo (ASL = .067). The high variance in healing rates, small sample size, and different ulcer status at discharge affected between-group comparison. *The authors recommended that future studies stratify subjects based on both ulcer stage and location.*

NONCONTACT NONTHERMAL ACOUSTIC PRESSURE THERAPY

A multicentre trial demonstrated that noncontact, nonthermal acoustic pressure therapy can stimulate healing of diabetic foot wounds.⁽²⁸⁾ Schmuckler reported on five cases in which acoustic pressure wound therapy was used to prepare chronic sacral pressure ulcers with $\geq 50\%$ slough or any eschar for electrical stimulation or other treatment.⁽²⁹⁾ Acoustic pressure wound therapy is a low-frequency, noncontact, nonthermal, ultrasound therapy that promotes healing through cleansing and debridement. It was used three times a week for 4 to 6 minutes per treatment, until necrotic tissue was removed, complete granulation had occurred, drainage had been reduced, and the wound was suitable for electrical stimulation. After 1 to 4 weeks, four ulcers were completely granulated, and wound area and volume had decreased 71% to 99%. Acoustic pressure wound therapy was an effective method of preparing chronic pressure ulcers for subsequent therapies. In some locations in Canada, it is difficult to obtain access to devices that deliver this therapy.

TOPICAL OXYGEN

Banks and Ho reported that oxygen therapy in three individuals with spinal cord injury and deep, nonhealing pressure ulcers had reduced wound size after 5 to 9 weeks of treatment.⁽³⁰⁾ Oxygen therapy was given using a commercially available device that concentrates oxygen from room air and delivers it to the wound base surface through a cannula.

MAGGOT THERAPY

Sherman treated 8 of 20 necrotic stage IV pressure ulcers in people with spinal cord injury with maggot therapy for 3 weeks and demonstrated better healing and faster wound debridement compared with 12 controls.⁽³¹⁾ Maggot therapy, using sterile laboratory-produced larvae, has been used safely in many types of nonhealing wounds.⁽³²⁾ This biological form of wound debridement selectively and rapidly removes foreign or devitalized tissues from all types of open wounds.⁽¹¹⁾ Access to appropriate sources of medical-grade fly larvae can be difficult in Canadian healthcare facilities.

TOPICAL RECOMBINANT GROWTH FACTORS

Becaplermin gel, a topical formulation of recombinant human platelet-derived growth factor-BB, was initially demonstrated effective in increasing healing in individuals with pressure ulcers.⁽³³⁾ A randomized, double-blind, placebo-controlled

phase 2 trial (N=63) found that becaplermin significantly increased all measures of healing full-thickness pressure ulcers compared with placebo ($p < .025$).⁽³³⁾ Scevola et al performed a prospective randomized pilot study of becaplermin in 13 people with spinal cord injury who had a total 16 pressure ulcers.⁽³⁴⁾ By the end of treatment, 15 of 16 ulcers improved clinically, but no significant difference was seen between becaplermin or placebo. Granulation tissue proliferation was triggered significantly faster in ulcers treated with becaplermin than in those treated with placebo, with most of the effect seen in the first 2 weeks. Prolonged treatment provided no additional benefit compared with best practice management. Becaplermin is currently approved in Canada for the treatment of diabetic foot ulcers.

RECOMBINANT HUMAN ERYTHROPOIETIN

Erythropoietin plays a crucial role in the regulation of hematopoiesis and induces red blood cell production. It also modulates inflammatory processes and thereby may reverse conditions responsible for the development of anemia of chronic disease.⁽¹⁵⁾  **CHAPTER 3, Body weight, nutrition, and hematologic and biochemical parameters of healing, includes information about anemia.**

A small case series suggested injections of recombinant erythropoietin were associated with improved healing of recalcitrant pressure ulcers in four people with spinal cord injury who had anemia of chronic disease.⁽³⁵⁾ A clinical trial evaluating the effect of recombinant erythropoietin administration to people with spinal cord injury who have anemia and pressure ulcers is currently in progress, but results are not yet available. No other research that has examined the use of erythropoietin to speed healing of pressure ulcers or other types of chronic wounds has been identified.

ANABOLIC STEROIDS

A report of nine cases of nonhealing pressure ulcers in people with spinal cord injury that were treated with a supplement containing oxandrolone included eight people with nonhealing wounds of 2 months' to 5 years' duration.⁽³⁶⁾ One person had a full-thickness ulcer that was reported to have been present for 2 weeks. Eight wounds were stage IV ulcers and one wound was a stage III ulcer. Participants received 1 to 12 months' treatment. Eight ulcers healed completely and one person was lost to follow-up. Oxandrolone therapy was associated with reversal of catabolism and weight gain. As a high concentration of glutamine was included with the oxandrolone, the separate benefits of anabolic steroid and amino acid supplementation could not be differentiated. *A properly randomized trial with a larger population is required to clarify the role of anabolic steroids in stimulating healing in chronic pressure ulcers in people with spinal cord injury.*  **CHAPTER 3, Body weight, nutrition, and hematologic and biochemical parameters of healing, includes information about protein supplementation and nutrition.**

ACTIVATED FACTOR XIII

Becker et al reported on the use of transglutaminase, or activated factor XIII, in a person with spinal cord injury, chronic recurrent pressure ulcers, and several complications after flap surgery.⁽³⁷⁾ Transglutaminase, which is activated by thrombin, has a variety of actions that result in fibroblast stimulation and replacement of the fibrin matrix by granulation tissue. The day before secondary closure of the flap, treatment with transglutaminase was initiated, and it was continued for 11 days. The flap was firmly attached by 2 weeks after surgery, and the site was completely healed 3 weeks later. This approach may be useful in individuals with complications and poor wound healing.

TENSION THERAPY

Adedoyin reported on the use of tension therapy in the management of sacral and ischial pressure ulcers in an individual with paraplegia.⁽³⁸⁾ The ischial ulcer was selected as the experimental wound and the sacral ulcer was selected as the control. Tension therapy involved four cycles of passive mobilization of the hip for 5 minutes, followed by 1 minute of release, administered four times a week for 5 weeks. Both ulcers were also treated conventionally. At the end of the study, the surface area of the ischial ulcer had decreased to 60.5% of the original size, whereas the area of the sacral ulcer had expanded by 19.6%. This case illustrates the potential of a simple technique to promote wound healing. *Additional research is needed on the benefits of tension therapy.*

HYPERBARIC OXYGEN

In ischemic wounds, hyperbaric oxygen can provide the tissue oxygenation required for healing.⁽⁷⁾ This treatment modality has been successful in managing diabetic foot ulcers, but evidence is lacking in both pressure ulcers in general and in the spinal cord injury population specifically. *Additional research is needed on the benefits of hyperbaric oxygen in the treatment of pressure ulcers.*



Adjunctive therapies not recommended for treatment of pressure ulcers in people with spinal cord injury

ULTRASOUND

The role of therapeutic ultrasound in healing pressure ulcers is unknown. One clinical trial evaluated the effect of therapeutic high-frequency ultrasound on pressure ulcer healing in people with spinal cord injury.⁽³⁹⁾ Nussbaum et al reported that the combination of therapeutic ultrasound and UVC administered on alternate days was effective in reducing the size of chronic pressure ulcers in people with spinal cord injury. Unfortunately, it is not possible to distinguish the benefits of ultrasound from those of UVC, as both modalities were used concurrently.

NEGATIVE PRESSURE WOUND THERAPY

Insufficient evidence exists to recommend negative pressure wound therapy (NPWT) to speed the closure of chronic pressure ulcers in people with spinal cord injury. Systematic review of this literature revealed one case series that examined the use of this therapy in people with spinal cord injury.^(5,15) Coggrave suggested that NPWT might be useful to prepare wounds for surgical closure (see Preoperative considerations, Infection).⁽⁴⁰⁾ Topical NPWT is routinely used in people with spinal cord injury with chronic pressure ulcers. Several clinical case studies of NPWT applied to acute or freshly debrided wounds have been published, but few have included participants with chronic wounds. One randomized study with 22 people with spinal cord injury found no appreciable difference between standard wound treatment and standard therapy plus NPWT.⁽⁴¹⁾ Based on current evidence in all types of chronic wounds, a Cochrane review concluded no evidence supported use of this therapy to speed the closure of chronic wounds.⁽⁴²⁾

LASERS

A randomized clinical trial involving 35 people with a total of 64 pressure ulcers did not detect significant differences between wound size changes after real or sham laser treatment.⁽⁴³⁾ Negative findings reported in this well-designed study involving people with spinal cord injury confirmed previous reports involving participants with pressure ulcers and spinal cord injury.⁽³⁹⁾ In addition, several clinical reports involving a general population with pressure ulcers and other chronic wounds have failed to detect an improvement in healing when laser treatment was included in therapy.⁽⁴⁴⁾ Therefore, laser therapy should not be used to treat pressure ulcers.

TOPICAL PHENYTOIN

A small, well-designed, randomized clinical study comparing saline-soaked gauze with and without added phenytoin (5 mg/mL) did not show improvement in healing of pressure ulcers in people with spinal cord injury.⁽⁴⁵⁾ Hollisaz et al compared healing rates of pressure ulcers treated with a dressing including phenytoin with a simple gauze and a hydrocolloid dressing.⁽¹²⁾ Healing rates and number of closed wounds were highest for those covered with the hydrocolloid dressing and not better than controls for phenytoin-treated wounds. Thus, current research suggests that phenytoin should not be added to saline-soaked gauze dressings for pressure ulcers in people with spinal cord injury, as it may interfere with healing.

Surgical treatment

PRINCIPLES

Surgical pressure ulcer repair involves extensive manipulation of soft tissues throughout the buttock and leg regions and possibly skin grafting. Serious complications can occur. Postoperative care involves extended hospitalization and requires substantially curtailed sitting for several weeks postoperatively. The incidence of recurrence of pressure ulcer after surgical closure is around 28 to 36%⁽⁴⁶⁾ but can be as high as 69% (see Surgical complications Page 185).⁽⁴⁷⁾ The associated cost is also significant. As both the resource costs and risks associated with the surgery are high, careful consideration is needed before deciding to perform the surgery. Extensive preoperative planning is then required to ensure optimal outcomes.

Interprofessional team

9.9: Preoperative evaluation

Assemble an interprofessional team to ensure optimal management of the person and the ulcer before, during, and after surgery, including:

- Selecting appropriate surgical candidates
- Performing a comprehensive assessment
- Implementing appropriate preoperative management
- Selecting the best surgical option and implementing it with expertise
- Planning and implementing optimal postoperative care

RECOMMENDATION LEVEL IV



An interprofessional team is critical to adequate preoperative assessment and management (TABLE 1).

It is important to have a thorough understanding of the person and history, including spinal cord injury level and duration, the number of previous pressure ulcers and recurrence history, and any history of previous pressure ulcer surgeries. Many people presenting for surgical repair of pressure ulcers have not had any follow-up involving a rehabilitation team for 10 to 15 years. Very often, little information is available. More people need surgical repair of pressure ulcers than can receive it in a reasonable time.

Criteria for surgical closure of a pressure ulcer

9.10: Surgical referral

Refer appropriate individuals with complex, deep, stage III pressure ulcers, which may include ulcers with undermining or sinus tracts, and those with stage IV pressure ulcers for surgical evaluation.

RECOMMENDATION LEVEL IIA

Thorough assessment is a prerequisite when surgical closure of a pressure ulcer is being considered. Surgical closure speeds healing of full-thickness ulcers. The associated wound complication rate can be minimized (< 15%) with appropriate postoperative management. Several criteria should be met for the ulcer to be closed surgically. These factors relate both to the individual and the wound.





Criteria for surgical closure of a pressure ulcer from the RNAO best practice guideline are the following⁽⁷⁾:

- The ulcer is a clean, granulating stage III or IV ulcer.
- Continuous pressure on the surgical site can be avoided.
- Surgical closure is likely to improve quality of life.
- The person:
 - » Is motivated and knowledgeable about pressure ulcer prevention, understands the cause of the ulcer, and is likely to cooperate with necessary postoperative interventions
 - » Has adequate psychosocial, financial, and social support resources and living environment
 - » Can tolerate surgery, does not have a short lifespan, and is likely to experience improved quality of life

Table 1. Interdisciplinary Approach to Surgical Management of Pressure Ulcers in Individuals with Spinal Cord Injury: Example

ACTION	PREOPERATIVE ASSESSMENT	DAY OF PROCEDURE	POSTOPERATIVE PERIOD			
			24 HOURS	1 WEEK	3 WEEKS	6 WEEKS
Tests	<i>Blood:</i> CBC, albumin, prealbumin <i>X-ray:</i> chest, surgical site C&S wound & urine	Tissues sent for culture and pathology	CBC Electrolytes			
Consultations	OT PT Anesthesia Nutrition (to follow)			Home care if to be discharged Assess support surface needs (bed)	Reassess support surface needs (bed) Arrange sitting check	Sitting check Support surface
Activity		Bed rest, support surface	Flat Careful movement	Bed rest	Sitting ½ hr initially	Sitting
Diet		High protein and calorie as tolerated				
Treatments	Wound assessment	Vital signs q4h Drains Dressing care Bowel routine Chest physiotherapy	Wound examination Wound dressing Skin assessment	Drain out	Suture removal	
Medications	Antibiotics in the OR	Antibiotics x 7 days per culture O ₂ by mask	D/C O ₂ D/C IV if possible			
Discharge Planning	Assess discharge care plan Home care Order pressure relief mattress No smoking		Review discharge plan	Bedrest x 3 weeks	Skin & wound check Seating assessment: 2 months	Equipment Appointment Seating assessment
Education						Pressure relief Skin care

Adapted from Dr J Mahoney and used with permission.

PREOPERATIVE CONSIDERATIONS



The success of surgery to manage pressure ulcers depends on detailed and effective assessment and management of multiple factors.

According to the RNAO best practice guidelines for the assessment and treatment of pressure ulcers⁽⁷⁾, the following factors should be assessed and treated before surgery:

- Psychosocial status
- Local wound infection
- Nutritional status
- Incontinence
- Severe spasm and contractures
- Comorbid conditions
- Previous ulcer surgery
- Smoking
- Osteomyelitis
- Urinary tract infection
- Ulcer complications
- Heterotopic ossification

Infection



Persistent bacteremia from pressure ulcer infection is associated with high mortality.⁽¹¹⁾

Careful debridement, including debridement of exposed infected bone and use of perioperative antibiotic therapy can prepare the wound for closure. Once the wound is stable and free of infection, surgical wound closure can be considered. Sinograms are helpful in assessing sinus tracts. Computed tomography and magnetic resonance imaging can be helpful in assessing bone and soft tissue. NPWT can help in managing exudate, decolonizing pressure ulcers, and optimizing the wound bed before surgery.⁽⁴⁸⁾

9.11: Negative pressure wound therapy

Consider the utility of negative pressure wound therapy in preparing pressure ulcers for surgical closure...

RECOMMENDATION LEVEL III

Coggrave et al found that NPWT, used for seven individuals with spinal cord injury, helped prepare open wounds for surgical repair.⁽⁴⁰⁾ Few problems or adverse reactions were associated with applying the suction device to these wounds where sensory feedback was impaired or absent. As individuals also received optimal pressure redistribution and nutritional supplementation as part of preoperative care, it is not possible to determine the effect of adding NPWT to the preoperative care plan.

Nutrition

9.12: Nutrition

Involve a registered dietitian to assess nutritional status and correct preoperatively nutritional imbalances that are anticipated to have a significant effect on the success of surgical repair.

RECOMMENDATION LEVEL III



Nutritional imbalances are often present in debilitated individuals.⁽⁴⁸⁾ Numerous nutrition-related parameters have previously been assumed to adversely affect surgical outcomes of pressure ulcer repair, but specific recommendations for serum levels, hemoglobin, and other factors before surgical pressure ulcer repair have not been rigorously evaluated for their impact on postoperative healing. Surgery is not recommended in debilitated individuals, and the following specific levels for biochemical and hematologic indices have been recommended preoperatively but not rigorously evaluated for their impact on surgical wound healing^(48,49):

- Serum protein > 60 g/L
- Albumin > 35 g/L
- Hemoglobin > 120 g/L
- Transferrin > 1.8 g/L
- Lymphocyte count > 1.5 10.9/L
- Nitrogen balance: positive

Estrella and Lee performed a retrospective chart review of the use of interprofessional care in allowing early surgical reconstruction of deep sacral pressure ulcers in 16 people with moderate-to-severe hypoalbuminemia, rather than delaying surgery until after normalization of serum albumin.⁽⁴⁸⁾ Wound-related complications were seen in six individuals. An average 2.56 procedures per person were required for coverage, and average follow-up duration was 11.25 months. On final follow-up, 15 of 16 flaps had healed. The chart review suggested sacral ulcer flap surgery can be performed successfully in people with hypoalbuminemia using a protocol involving interprofessional care and collaboration.

Incontinence

Although uncommonly used, a temporary diversion colostomy may be helpful or necessary to control fecal incontinence when ulcers are near the anus, to minimize the risk of postoperative infection and to facilitate perineal care. De la Fuente et al compared outcomes of surgical treatment of perineal ulcers in people who also had colostomy (n=41) performed with those who did not (n=26).⁽⁵⁰⁾ A retrospective review of 67 cases, 59 of which had spinal cord injury, assessed recurrence rates, healing times, morbidity and mortality, and number of revisions for the colostomy and noncolostomy groups. Most colostomy procedures were performed laparoscopically. Quality-of-life assessment was performed in the people with colostomy. Recurrence was lower in the colostomy group (43%) than in the noncolostomy group (69%, $p < .05$). The colostomy group also had a shorter healing time (3 months) than the noncolostomy group (7 months, $p < .05$) and required fewer surgical procedures for ulcer repair than the noncolostomy group. Colostomy improved quality of life and bowel care. Laparoscopic colostomy is a safe procedure that reduces operative complications associated with open colostomy, facilitates pressure ulcer healing, and reduces the risk of recurrence.

Spasticity and contractures

Spasticity and contractures may be pressure ulcer etiologic factors. Severe spasticity can also cause postoperative wound dehiscence and should be managed preoperatively. Severe flexion contractures may be a factor in pressure ulcer development, and contractures may promote pressure ulcer recurrence. Interprofessional evaluation of spasticity is recommended. Surgical management may include preliminary flexor release. Nonsurgical options include botulinum toxin and pharmacologic neurolysis.

Botulinum toxin may be a useful adjunct in people with spasticity that is delaying pressure ulcer healing. Intiso and Basciani published a case report of a person with recurrent severe muscle spasms, affecting especially the buttocks, who had a chronic stage IV pressure ulcer in the gluteal area.⁽⁵¹⁾ The spasms had rendered treatment attempts ineffective. Botulinum toxin was infiltrated around the ulcer at baseline and 3 months later. The treatment weakened muscle contractions during spasms sufficiently to allow topical wound management to be effective, and the ulcer healed 6 months after treatment was started.

Regional neuroablation has also been performed to manage spasticity that is interfering with ulcer healing. Wilkes et al reported on a case of chronic ischial and trochanteric pressure ulcer that failed to heal after numerous therapies.⁽⁵²⁾ The

individual had severe pain accompanying the spasms, and none of the numerous pain or spasticity medications provided relief. The only way the person could relieve the pain and spasticity was by pulling his legs up to his chest. This position compromised circulation to the pressure ulcers and prevented healing. Alcohol ablation of the sciatic and femoral nerves relieved his pain and spasm, allowing the leg to be straightened. Flap surgery could then be performed, and healing progressed well.

Yasar et al performed a retrospective review of case records of people with spinal cord injury treated with phenol neurolysis of the obturator nerve to manage hip adductor spasticity.⁽⁵³⁾ The objective of the review, which included 20 individuals, was to determine the impact of neurolysis on pressure distribution at the interface of the sitting surface and buttock. Neurolysis significantly decreased the proportion of pressures > 37 mm Hg, increased the proportion of interface pressures between 0 and 37 mm Hg, and decreased hip adductor spasticity ($p < .001$ for all). In addition to managing spasticity, obturator neurolysis may be a promising intervention for pressure management, and it may reduce the risk of pressure ulcer.

Jaffe reported a case of Ashworth scale grade 4 spasticity of the legs in an individual with T4 complete spinal cord injury, which resulted in several functional impairments, disabilities, and medical complications.⁽⁵⁴⁾ Increasing spasticity contributed to pressure ulcers of the hips and feet and created problems with comfort and instrumental activities of daily living. Medical therapies to control spasticity were ineffective. Bilateral above-the-knee amputations resolved the medical complications and markedly improved quality of life.

Comorbidities

As with any other surgical procedure, it is important to stabilize comorbidities, such as cardiac or pulmonary disease and diabetes, preoperatively.

Previous pressure ulcer surgery

Success or failure of an individual flap surgery procedure is independent of the results of previous procedures in the same individual, with the exception of procedures that have limited current surgical options due to anatomical location or presence of scar tissue.

Smoking

The literature concerning the impact of smoking on postoperative healing, complications, or recurrence is contradictory, but smoking cessation is an important general health measure.

Osteomyelitis

No simple noninvasive way has been identified to diagnose osteomyelitis.⁽¹¹⁾ The choice of imaging modality depends on multiple factors and remains controversial. A negative bone scan rules out osteomyelitis, but a positive scan may not be diagnostic. Biopsy provides a definitive answer if the bone scan is abnormal. The combination of white blood cell count, erythrocyte sedimentation rate, and plain X-ray has demonstrated 89% sensitivity and 88% specificity. Magnetic resonance imaging may be useful in showing bone necrosis. Needle biopsy has a sensitivity of 73% and specificity of 96%. As long as infected bone is debrided adequately, the presence of chronic osteomyelitis preoperatively may not cause wound breakdown.

Appropriate debridement and surgical technique plus a short course of antibiotics can successfully treat chronic osteomyelitis associated with pressure ulcers. Marriott and Rubayi performed a retrospective analysis of 157 people with pressure ulcers.⁽⁵⁵⁾ Participants were divided into groups according to pathologic diagnosis: acute osteomyelitis, chronic osteomyelitis, and negative osteomyelitis. Shallow bone shavings were taken for histologic diagnosis, and deep shavings were taken for microbiologic analysis. After debridement, ulcers were closed with muscle or musculocutaneous flaps.

People with negative or chronic osteomyelitis received a 5- to 7-day course of intravenous antibiotics. People with acute osteomyelitis received 4 to 6 weeks of antibiotic therapy according to bone culture and sensitivity results. Postoperative length of stay, wound breakdown, and pressure ulcer recurrence did not differ between the groups.

Urinary tract infection

In longstanding spinal cord injury, urinary tract infection can be associated with strictures or perforation from self-catheterization. It is critical to manage urinary tract infection preoperatively to prevent sepsis. In addition, ischial and perineal pressure ulcers may extend into the urethra, producing a urethrocutaneous fistula.⁽⁵⁶⁾ In this situation, permanent urinary diversion is necessary before ulcer repair to prevent urine leakage and reduce the risk of renal failure due to ascending infection. Men with spinal cord injury and a history of urethral stricture requiring catheterization may require a urologic consultation.

Heterotopic ossification

Heterotopic ossification, the formation of bone in extraskeletal sites, is associated with decreased range of motion, contractures, and seating difficulties that can interfere with mobility and self-care and increase the risk of pressure ulcers. Imaging studies can diagnose this complication of spinal cord injury. Surgical removal of mature heterotopic ossification can restore joint mobility, but removal of immature bone may increase the risk of recurrence. The presence, degree, and impact of heterotopic ossification on pressure ulceration must be assessed preoperatively to determine the best course of action.

SURGICAL PROCEDURES



9.13: Surgical pressure ulcer management

Follow these tenets of surgical treatment when surgery is indicated:

- Debriding the wound, including excising the ulcer, surrounding scar, bursa, soft tissue calcification, and underlying necrotic or infected bone, possibly using dye-assisted debridement
- Filling dead space
- Enhancing the vascularity of the healing wound
- Redistributing pressure off the bone
- Resurfacing with a large regional pedicle flap, with the suture line away from the area of direct pressure and from adjacent flap territories, preserving options for potential future repairs

RECOMMENDATION LEVEL IIA

Debridement

Surgical debridement is the first and critical step in surgical management of a pressure ulcer. A variety of techniques have been developed to delineate the ulcer margin, including injection of methylene blue or hydrogen peroxide, but these approaches may have significant limitations, such as overflow into healthy tissue around the ulcer and incomplete marking of the ulcer. It has been suggested that a pseudo-tumour technique using silicone moulding allows rapid and complete preoperative debridement.⁽⁵⁷⁾ This technique was evaluated in a series of 10 people. Injection of the liquid silicone and vulcanization to solid silicone took approximately 6 minutes. This technique allowed radical en bloc no-touch debridement, with no perforation into the ulcer cavity, under palpatory control. No early complications occurred, and no complications or recurrence were seen in any subjects over a 2-year follow-up period. This technique is less reliable in patients with small cutaneous openings associated with significant sinus tracts.

Flap surgery

9.14: Flap selection

Consider the location of the wound, potential flaps, and optimal location-specific techniques for reconstruction when determining the surgical technique for a specific ulcer repair procedure.

RECOMMENDATION LEVEL IIB



Categories of flaps are the following:

- Flaps based on the type of tissue:
 - » Skin, fasciocutaneous, and myocutaneous flaps
 - » Perforator flaps
 - » Muscle and myofascial flaps
- Flap suggestions based on the anatomic location:
 - » Superior gluteal flaps for sacral ulcers
 - » Inferior gluteal flaps for ischial ulcers
 - » Adipofascial flaps for sacral, ischial, and trochanteric ulcers
 - » Turnover flaps for ischial ulcers
 - » Lateral and medial posterior thigh flaps for ischial ulcers
 - » Skin flaps for all types of pressure ulcers
 - » V-Y advancement flaps for sacral and ischial pressure ulcers
 - » Rotation flaps for all types of pressure ulcers
 - » Transposition flaps for all types of pressure ulcers

No literature suggests that any specific surgical technique is better than another for surgical repair of pressure ulcers. Different types of flaps are used to manage ulcers in different anatomical areas, and careful preoperative and postoperative planning is required to maximize surgical success. It is important to select the type of flap based on its specific indication for the area involved and the ability to harvest the flap again should the pressure ulcer recur. Previous surgery, extent of soft tissue damage, and duration of spinal cord injury can compromise flap circulation and viability. Perforator flaps are more recent options available for pressure ulcer reconstruction.

Margara et al, based on 15 years' experience, suggest that the first-choice flaps for specific areas are as follows⁽⁵⁸⁾:

- V-Y advancement hamstring myocutaneous flap for ischial ulcers
- V-Y advancement gluteus maximus myocutaneous flap for sacral ulcers
- Myocutaneous tensor fascia lata rotation flap for trochanteric ulcers

Maslauskas et al performed a retrospective analysis of data from 139 people with pressure ulcers to examine the characteristics of the ulcers, the methods of closure, and their effectiveness.⁽⁵⁹⁾ In 94 people, ulcers healed completely before discharge, and in 45 people, only small wounds were left at discharge. Eighty-one people were treated repeatedly. Ischial ulcers were the most common type (n=69). Pressure ulcers had been present for an average of 8.9 months before repair. The mean size of the ulcers was 42.62 cm. The size of the ulcer depended on the duration of paraplegia ($p < .05$). Myocutaneous flaps were used for 93 ulcers. The method of closure was a V-Y advancement technique over the sacral area (n=17), a gluteal rotation flap (n=35), or a V-Y advancement technique using hamstring flaps (n=41).

Zogovska et al presented an overview of a single centre's experience in surgical treatment of pressure ulcers with dermal flaps and adipose cutaneous rotation, transposition, and bipedicle flaps in 23 people, 16 of whom had spinal cord injury.⁽⁶⁰⁾ Sacral ulcers were the most common type and were present in 12 people. Trochanteric ulcers were present in five people, ischial ulcers in four people, and heel ulcers in two people. Pressure ulcers were closed using unilateral

rotation flaps (n=7), bilateral rotation flap (n=1), transposition flaps (n=10), bipedicular flaps (n=2), free-skin Thiersch autotransplant (n=2), and direct closure (n=1). Complications occurred in eight people and included hematoma due to drainage failure (n=3), infection (n=2, both in individuals with hematoma), dehiscence (n=3, one in a person with hematoma), and marginal necrosis (n=3). Late ulcer recurrence was seen in two individuals, due to inadequate bony prominence ablation.

ISCHIAL PRESSURE ULCER REPAIR

Lin et al reported on long-term outcomes of posterior-thigh fasciocutaneous flaps in 12 people with ischial pressure ulcers.⁽⁶¹⁾ Primary healing occurred in all cases, and all flaps survived. Mean follow-up was 62 months. Ischial ulcers recurred in two people at 24 and 27 months postoperatively. This type of flap was not associated with any donor site morbidity.

Lin et al also reported on the use of a modified gracilis myofasciocutaneous flap to treat 12 people with ischial pressure ulcers.⁽⁶²⁾ Primary wound healing occurred in all individuals. Primary flap survival was seen in 11 people, with one person experiencing partial flap necrosis. Mean follow-up was 44 months. Ischial ulcers recurred in one person at 13 months after surgery.

Borgognone et al reported coupling two independent flaps, a split-muscle gluteus maximus flap and a rhomboid fasciocutaneous local flap, for surgical management of ischial ulcers in 12 people.⁽⁴⁹⁾ All flaps survived. Average follow-up was 45 months. Recurrence was seen in one person at 20 months.

Homma et al described the use of a posteromedial thigh fasciocutaneous flap for the treatment of ischial pressure ulcers in 10 people.⁽⁶³⁾ Dissection revealed the vascular supply of the flap to be from the suprafascial vascular plexus and the musculocutaneous perforator. The musculocutaneous perforator was the dominant vascular supply, and the flap could be elevated safely by accurately outlining the skin island directly over the vascular pedicle and preserving proximal fascial continuity. Partial flap losses occurred in two people, due to the failure to include the perforator. The authors concluded the flap should be wider than 5 cm.

Ischial pressure ulcers are very common, and recurrence is often seen in this area. As a result, it is critical to preserve the main vascular pedicle during initial surgery. Kim et al reported the results of using an inferior gluteal artery perforator flap in 23 people.⁽⁶⁴⁾ In 10 people, the procedure was the second one at the same site. Average follow-up was 25.4 months. All flaps survived without major complications, although partial flap necrosis developed in one person. Secondary healing was achieved. Wound dehiscence occurred in six cases, but all healed well with secondary treatment. Relapse occurred in five cases due to tissue deficits, which were treated with bursectomy to fill the dead space and a muscle transposition flap.

Because recurrence after surgical treatment of ischial pressure ulcers is frequent, a sensate gracilis musculocutaneous flap can be used if sensation is present above L3. Tellioglu et al reported on the use of this approach in 12 people, four of whom had recurrent ulcers. Average follow-up was 8 months.⁽⁶⁵⁾ Sensation was tested and found to be present in the flaps. A nonsensory gracilis myocutaneous flap can be used for ischial pressure ulcers if the neurologic level is below L3, but the sensate gracilis myocutaneous flap should be chosen when sensation is present over the gracilis region, to restore sensation and reduce the risk of recurrence.

SACRAL PRESSURE ULCER REPAIR

Local gluteal flaps are usually preferred for closure of sacral pressure ulcers. Borman and Maral reported on a technique using a gluteal fasciocutaneous rotation-advancement flap with V-Y closure for treatment of sacral pressure ulcers in 15 people.⁽⁶⁶⁾ This technique combined rotation and V-Y advancement flaps. The tension at the distal rotation flap was relieved by advancement, and the combined flap was supported laterally with V-Y closure. A wide skin pedicle was preserved to augment blood supply to the flap and minimize the size of the incision, reducing the risk of fecal contamination and problems with wound healing. This type of flap can be converted to a fasciocutaneous or musculocutaneous V-Y

advancement flap, if required, and can be used to close large defects. No wound dehiscence or flap necrosis developed with follow-up of 1.5 to 35 months. The authors concluded the technique allowed fast and simple surgery with minimal morbidity and a good outcome.

Prado et al described operative results for closure of sacral defects that extended to bone in 30 people, 25 of whom had spinal cord injury.⁽⁶⁷⁾ Bilateral gluteal distal fasciocutaneous and proximal musculocutaneous vertical vector rotation-advancement flaps based on perforators were used, along with V-Y closures. All ulcers were closed successfully. After follow-up of 1 to 8 years, 27 people required no additional surgery, and three people had infection and partial dehiscence of the flaps that healed after reoperation with V-Y readvancement.

Tzeng et al presented a modification of the traditional time-consuming technique for harvesting the superior gluteal artery perforator flap, using a rotational and a tunnel method with only a short pedicle dissection.⁽⁶⁸⁾ These flaps were used to cover sacral pressure ulcers in 12 people. Eleven flaps survived and one flap, which had necrosis of the tip, healed by secondary closure. This harvesting technique allowed faster surgery with less bleeding and less pedicle trauma, making the technique useful for closing sacral defects.

Seyhan et al presented a simplified gluteal perforator flap surgical technique to repair pressure ulcers in 20 people with sacral (n=16), ischial (n=2), or trochanteric (n=2) pressure ulcers.⁽⁶⁹⁾ The technique depends on identifying a suitable perforator with a Doppler probe, outlining the flap, dissecting the perforator with adequate length, and transposing the flap. As the gluteal area has many perforators, it is unnecessary to sacrifice main arteries or to use strict anatomic landmarks to detect these vessels. No recurrence was seen in the same region.

PERINEAL PRESSURE ULCER REPAIR

Selection of flaps for sacral and perineal pressure ulcer repair should consider long-term high recurrence rates in people with spinal cord injury. Scheufler et al developed an infragluteal perforator flap that allowed future surgical reconstruction.⁽⁷⁰⁾ The authors defined the anatomy of the cutaneous branches of the descending inferior gluteal artery and cluneal nerves and anatomical landmarks using cadaver dissection. Infragluteal perforator-based flaps with an additional skin bridge were used in 13 people with paraplegia for four perineal and one sacral ulcer, and perforator flaps were used for six perineal and two sacral ulcers. One or two descending cutaneous inferior gluteal artery branches and one or two cluneal nerves were located at the lower gluteus maximus muscle border. These branches, which supplied the infragluteal perforator flap, allowed creation of flaps with improved mobility compared with perforator-based flaps and preserved options for future flaps. Twelve flaps healed uneventfully, and in one person, total flap necrosis occurred, caused by impaired venous drainage and congestion.

OLECRANON PRESSURE ULCER REPAIR

Among people with tetraplegia, the peri olecranon region undergoes constant shear and pressure. Bursitis commonly develops, followed by a pressure ulcer. Conservative treatment is unlikely to produce healing, and surgical closure is challenging. Rubayi and Kiyomo described surgical management of this problem in seven people with tetraplegia.⁽⁷¹⁾ Participants had an olecranon pressure ulcer or septic olecranon bursitis. Closure was achieved with a local arm fasciocutaneous flap or a cross-chest flap. Primary wound healing was achieved, and no loss of elbow range of motion occurred. At 10 to 12 months postoperatively, olecranon pressure ulcer or septic bursitis recurred in three people, requiring revision. The local fasciocutaneous rotational flap was used for recurrence. No reconstructive methods can prevent recurrence as long as predisposing factors are present. Education is essential for prevention of recurrence.

REPAIR OF COMPLEX BACK WOUNDS

Meiners et al performed a retrospective review of surgical repair of complex back wounds with a latissimus muscle flap in 14 people with spinal cord injury.⁽⁷²⁾ Six people had deep wound infection and wound dehiscence following spondylosis, six people had dead space and wound dehiscence following laminectomy, and two people had pressure ulcers over the

spine. Primary closure was performed in nine people, and a split-thickness skin graft was used in five people. Primary healing was achieved in 11 cases, and complications occurred in three cases, which required five additional procedures. At a mean follow-up of 27.4 months, all wounds were healed and no functional restrictions had occurred. The authors concluded that a reverse latissimus muscle flap is a reliable technique to manage complex back wounds in people with spinal cord injury without functional loss.

Amputation and salvage surgery



9.15: Amputation and salvage surgery

Perform amputation when pressure ulcers have proven refractory to surgery, to manage spasticity associated with chronic ulceration, or to remove a flail limb.

Perform salvage surgery in situations where it is lifesaving.

RECOMMENDATION LEVEL III

Extensive surgical resection of infected bone and soft tissue is sometimes required. Wound closure may not be feasible, and a prolonged wound management course is required. Resection of the hip and proximal femur is called a Girdlestone procedure. Rare cases of life-threatening septic complications of pressure ulcers may require amputation, sometimes extensive. Chan et al conducted a retrospective review of hemipelvectomy, an extensive amputation, using data from the Department of Veterans Affairs to identify clinical features of people requiring the procedure.⁽⁷³⁾ The search identified eight cases over a 10-year period (1989–1998). All cases had complete spinal cord injury and developed severe pressure ulcers complicated by pelvic osteomyelitis or life-threatening soft tissue infections. Multiple medical comorbidities were present in all cases. Mean blood loss was 2.6 litres. Postoperative complications and revisions were common. The mortality rate of 25% appeared to be related primarily to the debility associated with spinal cord injury. When hemipelvectomy is performed in people without spinal cord injury, mortality rates of 2 and 3% have been reported. This suggests that intensive perioperative care may reduce the complication rate in people with spinal cord injury. People who survived benefited significantly from the procedure.

Correa et al described a series of five cases involving people with spinal cord injury and recurrent pressure ulcers complicated by osteomyelitis who underwent proximal leg amputation.⁽⁷⁴⁾ The recurrent pressure ulcers resulted in frequent and prolonged hospital stays and were associated with psychological deterioration. The procedure used was partial hemipelvectomy in three cases and hip disarticulation in two cases. No major complications occurred. After the procedure, attention to self-care improved, and the number of pressure ulcers, procedures, and hospital days decreased significantly. These salvage procedures effectively managed life-threatening problems.

Other salvage procedures include hindquarter and bilateral hindquarter amputation. This disarticulation is performed at the level of the pelvis. Candidates for these radical surgical procedures may have refractory pressure ulcers and potentially life-threatening infection, and they have a high risk of complications and mortality. Intensive psychosocial and postoperative support is required. A prosthetic limb may be required, and the entire seating system may require replacement.

POSTOPERATIVE MANAGEMENT

9.16: Postoperative management

Know and implement appropriate postoperative care after all pressure ulcer surgical repair:



- Assess and manage pain.
- Evaluate support surfaces.
- Position the individual to keep pressure off the surgical site.
- Consider using an active bed surface when pressure on the surgical flap is unavoidable.
- Arrange a seating and postural assessment at the appropriate time during the postoperative mobilization period.
- Progressively and gradually mobilize the individual to a sitting position over at least 4 to 8 weeks to prevent re-injury of the ulcer or surgical site.
- Provide education on pressure management and skin inspection.

RECOMMENDATION LEVEL IV



The success of surgical repair for pressure ulcer management relies on eliminating or modifying factors that contributed to formation of the ulcer and on implementing education on pressure management, skin inspection, and other preventive strategies.

Practical problems, such as the time required for delivery of specialized seating surfaces, may interfere with these plans and increase the risk of recurrence.

For the first 2 weeks postoperatively, it is important to avoid positioning the individual on the flap. After that, the surgical site can be gradually integrated into the repositioning schedule. Sitting can be resumed at 2 to 4 weeks postoperatively if the flap is intact and advanced based on individual progress.  **APPENDIX 7** provides an example of a postoperative mobilization protocol. Because of the potentially devastating effects of prolonged bed rest, the duration should be kept to an absolute minimum.  **CHAPTER 5, Beds, mattresses, and recumbent positioning,** includes information and recommendations about bed rest and alternatives for managing pressure over the ulcer.

It is important to perform passive stretching exercises to maintain range of motion and prevent contractures during the person's recovery from flap surgery. Preoperative optimization and adequate rehabilitation planning are also critical for achieving the best outcomes.

Surgical complications

9.17: Identify complications

Identify, prevent, and manage potential complications of surgical intervention on an individual basis, including:

- Hemorrhage
- Wound dehiscence or wound separation
- Delayed infection and abscess
- Hematoma and seroma
- Recurrence

RECOMMENDATION LEVEL IIB



Numerous perioperative complications may occur, including mortality. Complications are frequently due to underlying problems associated with spinal cord injury, including significant respiratory problems in people with tetraplegia, worsening spasticity, or increasing autonomic dysreflexia. Positioning during or after surgery may cause pressure ulcers. Wound disruption and infection are seen after surgical repair of pressure ulcers in people with spinal cord injury (Table 2).^(45,75,76) It is important to remember that these procedures are performed on contaminated wounds and are associated with a higher complication rate. Anything that can be done to optimize the status of the person and the wound can reduce the complication rate.

Table 2. Complication, Reoperation, and Recurrence Rates after Surgical Pressure Ulcer Repair

STUDY	NUMBER OF PRESSURE ULCERS (YEARS)	COMPLICATION RATE	RE-OPERATION RATE	RECURRENCE RATE
Disa ⁽⁴⁵⁾ (1992)	68 (8)	36%	NR	61%
Foster ⁽⁷⁶⁾ (1997)	280 (17)	28%	17%	12%
Schryvers ⁽⁷⁷⁾ (2000)	431 (20)	31%	13%	31%

NR: not reported

Early wound separation is usually due to mechanical factors related to spasticity or shear from positioning. Resuturing is often effective. Late separation due to ischemia and marginal necrosis may initially be managed with local wound care, and it may be possible to readvance the original flap to close the wound. Late separation may also be due to deep infection. Inflammation of the incision or fever may be present, but seropurulent drainage may be the only sign of deep infection. In this situation, the wound needs to be opened further to facilitate drainage and dressing changes. Excessive bleeding, drainage, or swelling of the flap may signal a hematoma. A hematoma developing early after surgery should be evacuated surgically and any bleeding controlled. A deep hematoma liquefies after about 10 days, resulting in dark sanguineous drainage from the suture line and possible wound breakdown.

Wound infections in people with spinal cord injury do not differ from those in people without spinal cord injury and can be treated in the same way as infections occurring in pressure ulcers in the general population. The pressure ulcer is often the source of a postoperative systemic infection, but if the wound shows no signs of infection, another source, such as the urinary tract, may be responsible. As organisms present at the surgical site may differ substantially from organisms deep in the wound, tissue biopsy may provide the best sample for culture and sensitivity. A sample for culture should be obtained before initiating antibiotic therapy.

 **APPENDIX 6** provides a method for swabbing wounds for culture.

CHAPTER 8, *Assessment after development of a pressure ulcer*, provides information about assessing for infection.

CONCLUSIONS

The treatment of pressure ulcers is lengthy, complex, and associated with multiple complications. Although initial treatment may be successful, recurrence affects overall success rates. Pressure ulcers cause serious morbidity and mortality in people with spinal cord injury and consume a vast amount of healthcare resources. The optimal approach to pressure ulcers is prevention. Education, pressure management, and constant vigilance are critical to prevention. Comprehensive pressure management education is crucial for the individual; caregivers, including family members; and healthcare providers at all levels for effective prevention and for recognition of pressure ulcers at the earliest stages, when they can be more easily treated. When prevention fails, it is vital to recognize early pressure ulcers and treat them aggressively to prevent progression.

REFERENCES

1. Sibbald RG, Goodman L, Woo KY, Krasner DL, Smart H, Tariq G, et al. Special considerations in wound bed preparation 2011: an update. *Adv Skin Wound Care* 2011;24:415–35.
2. Houghton PE, Campbell KE, Fraser CH, Harris C, Keast DH, Potter PJ, et al. Electrical stimulation therapy increases rate of healing of pressure ulcers in community dwelling people with spinal cord injury. *Arch Phys Med Rehabil* 2010;91:669–78.
3. Apelqvist J, Bakker K, van Houtum WH, Schaper NC. Practical guidelines on the management and prevention of the diabetic foot: based upon the International Consensus on the Diabetic Foot (2007). Prepared by the International Working Group on the Diabetic Foot. *Diabetes Metab Res Rev* 2008;24(Suppl 1):S181–7.
4. Krishnan S, Nash F, Baker N, Fowler D, Rayman G. Reduction in diabetic amputations over 11 years in a defined UK population: benefits of multidisciplinary team work and continuous prospective audit. *Diabetes Care* 2008;31:99–101.
5. Consortium for Spinal Cord Medicine Clinical Practice Guidelines. Pressure ulcer prevention and treatment following spinal cord injury: a clinical practice guideline for health-care professionals. *J Spinal Cord Med* 2001;24(Suppl 1):S40–101.
6. Norton L, Sibbald RG. Is bed rest an effective treatment modality for pressure ulcers? *Ostomy Wound Manage* 2004;50:40–53.
7. Registered Nurses' Association of Ontario. Nursing Best Practice Guideline: Assessment & Management of Stage I to IV Pressure Ulcers 2011. Available at <http://www.rnao.org/bestpractices>. Accessed June 5, 2011.
8. European Pressure Ulcer Advisory Panel and National Pressure Ulcer Advisory Panel. Treatment of pressure ulcers: quick reference guide. Washington, DC: National Pressure Ulcer Advisory Panel; 2009. Available at <http://www.npuap.org>. Accessed June 5, 2011.
9. Makhosou M, Lin F, Knaus E, Zeigler M, Rowles DM, Gittler M, et al. Promote pressure ulcer healing in individuals with spinal cord injury using an individualized cyclic pressure-relief protocol. *Adv Skin Wound Care* 2009;22:514–21.
10. World Union of Wound Healing Societies. Principles of best practice: wound infection in clinical practice. An international consensus. London: MEP Ltd; 2008. Available at <http://www.mep Ltd.co.uk>. Accessed June 5, 2011.
11. Keast DH, Parslow N, Houghton PE, Norton L, Fraser C. Best practice recommendations for the prevention and treatment of pressure ulcers: update 2006. *Wound Care Canada* 2006;4:31–43.
12. Hollisaz MT, Khedmat H, Yari F. A randomized clinical trial comparing hydrocolloid, phenytoin and simple dressings for the treatment of pressure ulcers [ISRCTN33429693]. *BMC Dermatol* 2004;4:18.
13. Kaya AZ, Turani N, Akyuz M. The effectiveness of a hydrogel dressing compared with standard management of pressure ulcers. *Wound Care* 2005;14:42–4.
14. Whittle H, Fletcher C, Hoskin A, Campbell K. Nursing management of pressure ulcers using a hydrogel dressing protocol: four case studies. *Rehabil Nurs* 1996;21:239–42.
15. Regan M, Teasell RW, Keast D, Aubut JL, Foulon BL, Mehta S. Pressure ulcers following spinal cord injury. In: Eng JJ, Teasell RW, Miller WC, Wolfe DL, Townson AF, Hsieh JTC, et al, eds. *Spinal Cord Injury Rehabilitation Evidence*, 2010. Version 3.0.
16. Adegoke BO, Badmos KA. Acceleration of pressure ulcer healing in spinal cord injured patients using interrupted direct current. *Afr J Med Sci* 2001;30:195–7.
17. Baker LL, Rubayi S, Villar F, Demuth SK. Effect of electrical stimulation waveform on healing of ulcers in human beings with spinal cord injury. *Wound Repair Regen* 1996;4:21–8.
18. Griffin JW, Tooms RE, Mendius RA, Clift JK, Vander ZR, El Zeky F, et al. Efficacy of high voltage pulsed current for healing of pressure ulcers in patients with spinal cord injury. *Phys Ther* 1991;71:433–44.
19. Barczak M, Kluger P, Kluger J, Bauerle J, Puhl W. Therapeutic effectiveness of electric stimulation in paraplegic patients with pressure sores [dissertation of M. Barczak]. Orthopedic Department, Medical School of University of Ulm, Ulm; 2001.
20. Jercinovic A, Karba R, Vodovnik L, Stefanovska A, Kroselj P, Turk R, et al. Low frequency pulsed current and pressure ulcer healing. *IEEE Trans Rehabil Eng* 1994;2:225–33.
21. Houghton PE, Koel G. Electrical stimulation increases number of ulcers healed. Preliminary findings of a Cochrane review. *World Congress of Physical Therapy* 2011; Amsterdam; June 2011.
22. Adunsky A, Ohry A. Decubitus direct current treatment (DDCT) of pressure ulcers: results of a randomized double-blind placebo controlled study. *Arch Gerontol Geriatr* 2005;41:261–9.
23. Ahmad ET. High voltage pulsed galvanic stimulation: effect of treatment durations on healing of chronic pressure ulcers. *Ann Burns Fire Disasters* 2008;21:124–8.
24. Houghton PE, Koel G. Electrical stimulation increases number of ulcers healed. Preliminary findings of a Cochrane review. *World Congress of Physical Therapy* 2011, Amsterdam, Netherlands, June 2011.

25. Kloth LC, Zhao M. Chapter 26: Endogenous and exogenous electrical fields for wound healing. In: McCulloch JM, Kloth LC, eds. *Wound Healing Evidence Based Management*. 4th Edition. Philadelphia, PA: FA Davis Company; 2010. pp. 450–513.
26. Salzberg CA, Cooper-Vastola SA, Perez FJ, Viehbeck MG, Byrne DW. The effects on non-thermal pulsed electromagnetic energy (Diapulse®) on wound healing of pressure ulcers in spinal cord-injured patients: a randomized double-blind study. *Wounds* 1995;7:11–6.
27. Nussbaum E, Flett H, McGillivray C. Ultraviolet-C (UVC) improves wound healing in persons with spinal cord injury (SCI). Presented at the International Conference on Spinal Cord Medicine and Rehabilitation in Washington, DC; June 4–8, 2011.
28. Ennis WJ, Formann P, Mozen N, Massey J, Conner-Kerr T, Meneses P. Ultrasound therapy for recalcitrant diabetic foot ulcers: results of a randomized, double-blind, controlled, multicenter study. *Ostomy Wound Manage* 2005;51:24–39.
29. Schmuckler J. Acoustic pressure wound therapy to facilitate granulation tissue in sacral pressure ulcers in patients with compromised mobility: a case series. *Ostomy Wound Manage* 2008;54:50–3.
30. Banks PG, Ho CH. A novel topical oxygen treatment chronic and difficult-to-heal wounds: case studies. *J Spinal Cord Med* 2008;31:297–301.
31. Sherman RA. Maggot versus conservative debridement therapy for the treatment of pressure ulcers. *Wound Repair Regen* 2002;10:208–14.
32. Opletalova K, Blaizot X, Mourgeon B, Chene Y, Creveuil C, Combemale P, et al. Maggot therapy for wound debridement: a randomized multicentre trial. *Arch Dermatol* 2012;148:432–8.
33. Rees RS, Robson MC, Smiell JM, Perry BH. Becaplermin gel in the treatment of pressure ulcers: a phase II randomized, double-blind, placebo-controlled study. *Wound Repair Regen* 1999;7:141–7.
34. Scevola S, Nicoletti G, Brent F, Isernia P, Maestri M, Faga A. Allogenic platelet gel in the treatment of pressure sores: a pilot study. *Int Wound J* 2010;7:184–90.
35. Keast DH, Fraser C. Treatment of chronic skin ulcers in individuals with anemia of chronic disease using recombinant human erythropoietin (EPO): a review of four cases. *Ostomy Wound Manage* 2004;50:64–70.
36. Spungen AM, Koehler KM, Modeste-Duncan R, Rasul M. 9 clinical cases of nonhealing pressure ulcers in patients with spinal cord injury treated with an anabolic agent: a therapeutic trial. *Adv Skin Wound Care* 2001;14:139–44.
37. Becker SWJ, Weidt F, Rohl K. The role of plasma transglutaminase (F XIII) in wound healing of complicated pressure sores after spinal cord injury. *Spinal Cord* 2001;39:114–7.
38. Adedoyin AR, Olaogun MOB, Omojola OF, Adenekan MK. Effect of tension therapy in the management of pressure ulcers — a case report. *S African J Physiother* 2003;59:16–20.
39. Nussbaum EL, Biemann I, Mustard B. Comparison of ultrasound/ultraviolet-C and laser for treatment of pressure ulcers in patients with spinal cord injury. *Phys Ther* 1994;74:812–25.
40. Coggrave M, West H, Leonard B. Topical negative pressure for pressure ulcer management. *Br J Nurs* 2002;11(6 Suppl):S29–36.
41. Wanner MB, Schwarzl F, Strub B, Zaech GA, Pierer G. Vacuum-assisted wound closure for cheaper and more comfortable healing of pressure sores: a prospective study. *Scand J Plast Reconstr Surg Hand Surg* 2003;37:28–33.
42. Evans D, Land L. Topical negative pressure for treating chronic wounds: review: *The Cochrane Library* 2005;1:1–7.
43. Taly AB, Sivaraman Nair KP, Murali T, John A. Efficacy of multiwavelength light therapy in the treatment of pressure ulcers in subjects with disorders of the spinal cord: a randomized double-blind controlled trial. *Arch Phys Med Rehabil* 2004;85:1657–61.
44. Houghton PE, Campbell KE. Chapter 42: Therapeutic modalities in the treatment of chronic recalcitrant wounds. In: Krasner DL, Rodheaver GT, Sibbald RG, Woo KY, eds. *Chronic Wound Care: A Clinical Source Book for Health Care Professionals*. 5th Edition. Wayne, PA: Health Management Publications Inc.; 2012.
45. Subbanna PK, Shanti FXM, George J, Tharion G, Neelakantan N, Durai S, et al. Topical phenytoin solution for treating pressure ulcers: a prospective, randomized, double-blind clinical trial. *Spinal Cord* 2007;45:739–43.
46. Disa JJ, Carlton JM, Goldberg NH. Efficacy of operative cure in pressure sore patients. *Plast Reconstr Surg* 1992;89:272–8.
47. Kim YS, Lew DH, Roh TS, Yoo W, Lee WJ, Tark KC. Inferior gluteal artery perforator flap: a viable alternate for ischial pressure sores. *J Plast Reconstr & Aesthetic Surg* 2009;62:1347–54.
48. Hengstermann S, Fischer A, Steinhagen-Thiessen E, Schultz RJ. Nutrition status and pressure ulcer: what we need for nutrition screening. *J Parenter Enteral Nutr* 2007;31:288–94.
49. Estrella EP, Lee EY. A retrospective, descriptive study of sacral ulcer flap coverage in nonambulatory patients with hypoalbuminemia. *Ostomy Wound Manage* 2010;56:52–9.
50. Borgognone A, Annibolletti, De Vita F, Schirosi M, Palombo P. Ischiatic pressure sores: our experience in coupling a split-muscle flap and a fasciocutaneous flap in a 'criss-cross' way. *Spinal Cord* 2010;48:770–3.
51. De la Fuente SG, Levin LS, Reynolds JD, Olivares C, Pappas TN, Ludwig KA, Mantyh CR. Elective stoma construction improves outcomes in medically intractable pressure ulcers. *Dis Colon Rectum* 2003;46:1525–30.

52. Intiso D, Basciani M. Botulinum toxin type A in the healing of a chronic buttock ulcer in a patient with spastic paraplegia after spinal cord injury. *J Rehabil Med* 2009;41:1100–02.
53. Wilkes D, Ganceres N, Doulatram G, Solanki D. Alcohol neurolysis of the sciatic and femoral nerves to improve pressure ulcer healing. *Pain Pract* 2009;9:145–9.
54. Yasar E, Tok F, Taskaynatan MA, Yilmaz B, Balaban B, Alaca R. The effects of phenol neurolysis of the obturator nerve on the distribution of buttock-seat interface pressure in spinal cord injury patients with hip adductor spasticity. *Spinal Cord* 2010;48:828–31.
55. Jaffe MS. Elective bilateral above the knee amputation in T4-complete spinal cord injury: a case report. *Spinal Cord* 2008;46:585–7.
56. Marriott R, Rubayi S. Successful truncated osteomyelitis treatment for chronic osteomyelitis secondary to pressure ulcers in spinal cord injury patients. *Ann Plast Surg* 2008;61:425–9.
57. Hayashi T, Murazumi M, Mol W, Yamamoto Y. Surgical management of ischial and perineal pressure ulcers with urethrocutaneous fistulae. *J Wound Care* 2006;15:55–7.
58. Erba P, Wettstein R, Schumacher R, Schwenger-Zimmerer K, Pierer G, Kalbermatten DF. Silicone moulding for pressure sore debridement. *J Plast Reconstr Aesth Surg* 2010;63:550–3.
59. Margara A, Merlino G, Borsetti M, Bergamin F, Borsetti G. A proposed protocol for the surgical treatment of pressure sores based on a study of 337 cases. *Eur J Plast Surg* 2003;26:57–61.
60. Maslauskas K, Samsanavi ius D, Rimdeika R, Kaikaris V. Surgical treatment of pressure ulcers: an 11-year experience at the Department of Plastic and Reconstructive Surgery of Hospital of Kaunas University of Medicine. *Medicina (Kaunas)* 2009;45:269–75.
61. Zogovska E, Novevski L, Agai LJ, Mircevski V, Peev I, Dzokie GJ. Our experience in treatment of pressure ulcers by using local cutaneous flaps. *Prilozi* 2008;23:199–210.
62. Lin H, Hou C, Chen A, Xu Z. Long-term outcome of using posterior-thigh fasciocutaneous flaps for the treatment of ischial pressure sores. *J Reconstr Microsurg* 2010;26:355–8.
63. Lin H, Hou C, Chen A, Xu Z. Treatment of ischial pressure sores using a modified gracilis myofasciocutaneous flap. *J Reconstr Microsurg* 2010;26:153–7.
64. Homma K, Murakami G, Fujikota H, Fujita T, Imai A, Ezoe K, Wang TN. Treatment of ischial pressure ulcers with a posteromedial thigh fasciocutaneous flap. *Plast Reconstr Surg* 2001;108:1990–6.
65. Kim YS, Lew DH, Roh TS, Yoo WM, Lee WJ, Tark KC. Inferior gluteal artery perforator flap: a viable alternative for ischial pressure sores. *J Plast Reconstr Aesth Surg* 2009;62:1347–54.
66. Tellioglu AT, Tekdemir I, Akyüz M, Arifoglu K, Bilen BT, Ulusoy G, Sensöz O. Ischial pressure sores treated with a sensate gracilis myocutaneous flap. *Eur J Plast Surg* 2000;23:132–4.
67. Borman H, Maral T. The gluteal fasciocutaneous rotation-advancement flap with V-Y closure in the management of sacral pressure sores. *Plast Reconstr Surg* 2002;109:2325–9.
68. Prado A, Ocampo C, Danilla S, Valenzuela G, Reyes S, Guridi R. A new technique of “double-A” bilateral flaps based on perforators for the treatment of sacral defects. *Plast Reconstr Surg* 2007;119:1481–90.
69. Tzeng Y-S, Chen S-G, Yu C-C, Chen S-L, Chen T-M, Chiu T-F. Modification of superior gluteal artery perforator flap for reconstruction of sacral sores. *J Med Sci* 2007;27:253–8.
70. Seyhan T, Ertas NM, Bahar T, Borman H. Simplified and versatile use of gluteal perforator flaps for pressure sores. *Ann Plast Surg* 2008;60:673–8.
71. Scheuffler O, Farhadi J, Kovach SJ, Kukies S, Pierer G, Levin LS, Erdmann D. Anatomical basis and clinical application of the infragluteal perforator flap. *Plast Reconstr Surg* 2006;118:1389–1400.
72. Rubayi S, Kiyono Y. Flap surgery to cover olecranon pressure ulcers in spinal cord injury patients. *Plast Reconstr Surg* 2001;107:1473–81.
73. Meiners T, Flieger R, Jungclauss M. Use of the reverse latissimus muscle flap for closure of complex back wounds in patients with spinal cord injury. *Spine* 2003;28:1893–8.
74. Chan JWH, Virgo KS, Johnson FE. Hemipelvectomy for severe decubitus ulcers in patients with previous spinal cord injury. *Am J Surg* 2003;185:69–73.
75. Correa GI, Caldero WO, Roa RG, Guzman LM, Burnier LA, Danilla SE. Proximal amputation of inferior extremity secondary to recurrent pressure ulcers in patients with spinal cord injuries. *Spinal Cord* 2008;46:135–9.
76. Foster RD, Anthony JP, Mathes SJ, Hoffman WY, Young D, Eshima I. Flap selection as a determinant of success in pressure sore coverage. *Arch Surg* 1997;132:868–73.
77. Schryvers OI, Stranc MF, Nance PW. Surgical treatment of pressure ulcers: 20-year experience. *Arch Phys Med Rehabil* 2000;81:1556–62.

CONTENTS

PERSPECTIVES ON TELEREHABILITATION.....	193
RELEVANT EXAMPLES	193
Wound care	193
Pressure ulcers in spinal cord injury	194
Spinal cord injury	195
CANADIAN RESEARCH INITIATIVE	195
CONCLUSIONS.....	195
REFERENCES.....	196

Perspectives on telerehabilitation

10.1: Telerehabilitation

Consider telerehabilitation as a potentially useful approach for prevention and management of pressure ulcers in people with spinal cord injury.

RECOMMENDATION LEVEL IV

Telemedicine uses technology to deliver medical services to individuals located at either another institution or at home in the community. This approach to treatment is likely to become an important part of healthcare in Canada in future. The geographic size of Canada, the population distribution, and the concentration of healthcare expertise in larger urban centres create substantial inequities in access to care for individuals needing it and in opportunities for continuing education for healthcare professionals.

In clinical practice, telemedicine has applications in the education of healthcare professionals and patients, in consultations between specialists and primary healthcare professionals, and in consultations between healthcare professionals and patients. A recent review of clinical trials of telemedicine identified trials in neurology, diabetes, dermatology, psychiatry, cardiology, ophthalmology, acute care, transplant, otolaryngology, child abuse, endoscopy, general practice, leprosy, nephrology, and radiology.⁽¹⁾



In management of people with spinal cord injury, telerehabilitation is a way of providing interprofessional care that can link members of an interprofessional team with individuals with spinal cord injury and their caregivers during all phases of spinal cord injury across the continuum of care.

Little research is available on the impact of telerehabilitation on outcomes or costs of strategies to prevent or manage pressure ulcers in people with spinal cord injury. Wound care, however, is an example of a chronic disease whose management requires long-term specialized care.⁽²⁾ Wound care can build on telemedicine's achievements in other areas to create an effective telewound care model for people with spinal cord injury. The ability, knowledge, and technical resources are now available to develop telewound care programs that can provide high-quality care in a user-friendly, cost-effective way. Additional research is required to determine the best way to use telerehabilitation in caring for people with spinal cord injury.

RELEVANT EXAMPLES

Wound care

Dobke et al (2008) performed a prospective, randomized pilot trial to investigate the impact of telewound consultation using video-linked technology on 30 individuals in long-term care facilities. Participants had chronic wounds and were referred to the wound care program for assessment and management planning.⁽³⁾ Before an in-person consultation with a surgical wound care specialist, 15 participants received telewound feedback about their wound and the proposed treatment to facilitate communication with the surgical specialist. The impact of the intervention was measured by the length of the face-to-face consultation that followed, satisfaction with further care decisions, and validation of the



Decisional Conflict Scale. The average consultation length was 35 ± 6 minutes for the 15 individuals receiving the telewound intervention and 50 ± 12 minutes for the control group ($p < .01$). Telewound consultation increased the person's satisfaction with wound management decisions made during the face-to-face consultation. The acceptance rate was 93%, compared with 47% for individuals not receiving the video-linked technology feedback ($p < .01$). The average Decisional Conflict Scale score was 14 ± 1.73 in people receiving telewound feedback, compared with 35 ± 4.26 ($p < .001$) in the control group. Telewound feedback improved satisfaction with care, understanding, and the perception of shared decision-making, and it decreased the person's conflict about the correct course of action to take.

Dobke et al (2006) performed a study involving 120 people with nonhealing wounds referred to the wound care program for surgical consultation by their primary care physician.⁽⁴⁾ After the person's referral to the program, the field wound care nurse visited the person, obtained the history, assessed the wound, took digital wound photographs, and e-mailed the information to the surgical specialist. The specialist discussed the preliminary management plan with the nurse and then with the referring physician. During the face-to-face consultation, the surgical specialist assessed the person, confirmed management, and arranged care. In only two cases did the definitive plan, developed during the face-to-face consultation, differ from the initial management plan. The sensitivity of the consultation provided by video-linked technology was 94%, the specificity was 99%, and the positive predictive value was 94%.

Ablaza and Fisher developed a wound management system using video-linked technology and interprofessional teams comprised of physicians, visiting nurses, enterostomal therapists, occupational therapists, physiotherapists, dietitians, and others as necessary, to optimize wound management in the homecare setting.⁽⁵⁾ With this telewound system, the homecare nurse assesses the wound, documents the findings using audio recordings and photographs, and forwards the assessment electronically to the wound therapist, who analyzes the information, provides a diagnosis, and recommends a treatment plan to the team. The team provides input on the case, allowing formulation of a treatment plan that is presented to the attending physician for approval. This system allows people with wounds to receive comprehensive evaluation and specialty consultations in one step and prompt implementation of the treatment plan. This approach has also been found to enhance convenience and satisfaction, adherence, and treatment success. Such a system promotes development of practice guidelines and coordination of all home healthcare needs. Ongoing assessment and management uses a standard system, and wounds not following a typical healing trajectory are quickly identified.

Salcido reported on the use of technology to remotely assess and treat hard-to-heal ulcers in three individuals, using digital photography.⁽⁶⁾ The treating physician e-mailed serial photographs to a wound care specialist who diagnosed and assessed the wounds periodically and provided immediate treatment recommendations. The approach provided cost-effective and expert care.

PRESSURE ULCERS IN SPINAL CORD INJURY

Hill et al evaluated the reliability and validity of pressure ulcer assessment and diagnosis made via telewound by comparing two telewound modalities, telephone only and videoconferencing, with in-person assessment and diagnosis of pressure ulcer in 42 people with spinal cord injury.⁽⁷⁾ Diagnostic agreement (presence of pressure ulcer) was excellent for telephone (92%) and videoconferencing (97%). Diagnostic agreement with in-person diagnosis of pressure ulcer stage made via telephone (Spearman's rho 0.76) and videoconferencing (Spearman's rho 0.83) was almost perfect. Wound volume measurements made by telephone and videoconferencing were larger than in-person measurement. Bland-Altman plots found substantially narrower 95% limits of agreement with videoconferencing. This study found telephone contact to be a useful tool for identifying pressure ulcer presence. Videoconferencing was required for close agreement of ulcer assessment with in-person diagnosis.

Spinal cord injury

Dallolio et al performed a European multicentre, randomized, controlled trial to compare 6-month outcomes of telerehabilitation with standard care for people with spinal cord injury who had been discharged from a spinal cord unit to home, nursing, or unspecialized hospital care.⁽⁸⁾ The trial included 137 people with nonprogressive complete or incomplete spinal cord injury who were randomly allocated to the intervention group (n=69) or a control group (n=68). All participants received normal standard care, and the telerehabilitation group received 8 weekly telerehabilitation sessions followed by biweekly telerehabilitation sessions for 4 additional months. The main outcome measures were assessed at 6 months and included functional status, clinical complications, and satisfaction with care.

Functional Independence Measure (FIM) scores were higher ($p < .05$) in the telerehabilitation group only at one site.⁽⁴⁾ At this site, the total FIM score for the telerehabilitation group was 7.69 ± 6.88 , compared with 3.38 ± 4.43 for the control group. The FIM motor score for the telerehabilitation group was 7.55 ± 7.00 , compared with 3.24 ± 4.38 for the control group. No significant differences were seen in complications. Satisfaction with care was higher in the telerehabilitation group at all sites. This study provides initial quantitative evidence that the addition of telerehabilitation to standard care may be beneficial in the rehabilitation of people with spinal cord injury. Additional research is necessary to investigate the utility of telerehabilitation in people with spinal cord injury.

Yozbatiran et al developed a technique for measuring balance and leg force in people with spinal cord injury remotely and applied it in 21 people with spinal cord injury.⁽⁹⁾ Telerehabilitation-based and conventional clinical assessments were performed at baseline and 6 months later. Setting up the telerehabilitation equipment, positioning the individual, performing the measurements, and sending the data to the laboratory took approximately 30 minutes. Assessments were successfully acquired and transmitted on the first attempt. Several motor and sensory functions showed significant changes at 6 months. Changes in leg force, but not in balance, measured remotely, were significantly correlated with changes in several American Spinal Injury Association (ASIA) sensory and motor scores. Intra-rater reliability was better than inter-rater reliability. Telerehabilitation holds promise in remotely monitoring mobility changes in people with spinal cord injury.

CANADIAN RESEARCH INITIATIVE

Project: Feasibility of an Internet clinic for treating and preventing pressure ulcers: a collaboration with the Rick Hansen Institute translational research program

This multisite (Fredericton, NB; London, ON; Winnipeg, MB, and Calgary, AB) pilot investigation is assessing the feasibility of integrating several information technologies using the Internet to improve the prevention and treatment of pressure ulcers in people with spinal cord injury in Canada. Study participants will receive normal care, but the use of various technologies and secure communications will allow them to receive this care in their homes. The principal investigator is Dr Dalton Wolfe, and information is available through the Rick Hansen website.⁽¹⁰⁾

CONCLUSIONS

Telerehabilitation is a promising approach for delivering pressure ulcer prevention and management to people with spinal cord injury. Numerous ways already exist to use telerehabilitation, and further research is needed to determine its optimal use and benefits.

REFERENCES

1. Weerasinghe JU. Clinical trials of computer based telemedicine: a systematic review. *Sri Lanka J Bio-Med Inform* 2010;1:12-20.
2. Ong CA. Telemedicine and wound care. *Stud Health Technol Inform* 2008;131:211–5.
3. Dobke MK, Bhavsar D, Gosman A, De Neve J, De Neve B. Pilot trial of telemedicine as a decision aid for patients with chronic wounds. *Telemed J E Health* 2008;14:245–9.
4. Dobke M, Renkielska A, De Neve J, Chao J, Bhavsar D. Telemedicine for problematic wound management: enhancing communication between long-term care, skilled nursing, and home caregivers and a surgical wound specialist. *Wounds* 2006;18:256–61.
5. Ablaza VJ, Fisher J. Wound care via telemedicine: the wave of the future. Available at <http://hpsassociates.com/Woundcaretelemedicine.htm>. Accessed September 16, 2011.
6. Salcido, R. Embracing telemedicine in wound care. *Adv Skin Wound Care* 2010;23:391.
7. Hill ML, Cronkite RC, Ota DT, Yao EC, Kiratli BJ. Validation of home telehealth for pressure ulcer assessment: a study in patients with spinal cord injury. *J Telemed Telecare* 2009;15:196–202.
8. Dallolio L, Menarini M, China S, Ventura M, Stainthorpe A, Soopramanien A, et al, on behalf of the THRIVE Project. Functional and clinical outcomes of telemedicine in patients with spinal cord injury. *Arch Phys Med Rehabil* 2008;89:2332–41.
9. Yozbatiran N, Harness ET, Le V, Luu D, Lopes CV, Cramer SC. A tele-assessment system for monitoring treatment effects in subjects with spinal cord injury. *Telemed Telecare* 2010;16:152–7.
10. Rick Hansen Institute. Maintaining health at home. Available at <http://www.rickhanseninstitute.org/en/publications/news-archive/47-maintaining-health-at-home>. Accessed June 29, 2011.

CONTENTS

APPENDIX 1:	199
GUIDELINE DEVELOPMENT PROCESS.....	199
A. Search Terms	199
Scopus	199
Cochrane	199
Embase & Cinahl.....	199
Pubmed	199
B. PILOT TESTING SITES	200
Ontario Neurotrauma Foundation	200
APPENDIX 2:	201
IMPACT OF SPINAL CORD INJURY ON THE BODY.....	201
A. NEUROANATOMY	201
B. AMERICAN SPINAL INJURY ASSOCIATION (ASIA) IMPAIRMENT SCALE	204
C. TETRAPLEGIA AND PARAPLEGIA	204
Tetraplegia	204
Paraplegia	205
D. AUTONOMIC DYSREFLEXIA.....	205
E. ANATOMIC AND PHYSIOLOGIC CHANGES AFTER SPINAL CORD INJURY.....	206
Pain	206
Bone	206
Skeletal muscle	206
Endocrine system	206
Body weight	207
Cardiovascular system	207
Skin	207
Peripheral vascular perfusion	207
Lungs	207
Immunity	208
Aging	208
REFERENCES	208
USEFUL RESOURCES	208

APPENDIX 3:	209
NATIONAL PRESSURE ULCER ADVISORY PANEL: INTERNATIONAL PRESSURE ULCER CLASSIFICATION SYSTEM 2009	209
Stage I: Non-blanchable erythema	209
Stage II: Partial-thickness skin loss	209
Stage III: Full-thickness skin loss	210
Stage IV: Full thickness tissue loss	210
Unstageable or unclassified	211
Suspected deep tissue injury	211
APPENDIX 4:	212
SUPPORT SURFACES	212
A. TERMS AND DEFINITIONS RELATED TO SUPPORT SURFACES 2007	212
Physical concepts related to support surfaces	212
Components of support surfaces	213
Features of support surfaces	213
Categories of support surfaces	214
B. SUPPORT SURFACE SELECTION TOOL	214
C. REACTIVE SUPPORT SURFACE SELECTION TOOL	215
D. ACTIVE SUPPORT SURFACE SELECTION TOOL	215
APPENDIX 5:	216
GRADUATED SITTING PROTOCOL FOR PRESSURE ULCER MANAGEMENT	216
APPENDIX 6:	217
LEVINE METHOD FOR WOUND SWAB FOR CULTURE AND SENSITIVITY	217
APPENDIX 7:	218
MOBILIZATION PROTOCOL AFTER FLAP SURGERY	218
APPENDIX 8:	219
SPECIALIZED ASSESSMENT FORMS	219
A. PHYSIOTHERAPY ASSESSMENT FORM	219
B. PRESSURE MANAGEMENT ASSESSMENT TOOL	222
C. WINNIPEG HEALTH SCIENCES CENTRE	236
D: NEW SOUTH WALES STATE SPINAL CORD INJURY SERVICE, SPINAL SEATING PROFESSIONAL DEVELOPMENT PROJECT	258

APPENDIX 1:

Guideline development process

A. SEARCH TERMS

SCOPUS

Pressure ulcer
Spinal cord injury
Rehabilitation
Wound treatment
Lumbar support
Education

COCHRANE

Spinal cord injury AND pressure ulcers
1. (spin* NEXT cord NEAR/3 injur*)
2. (tetraplegi*) (quadriplegi*)
3. (paraplegi*)
4. (spin* NEXT cord NEAR/3 damag*)
5. (#1 OR #2 OR #3 OR #4 OR #5)
6. (pressure OR (deep NEXT tissue)
NEXT (ulcer* OR sore*))
7. (decubit*)
8. (bed NEXT (sore* OR ulcer*))
9. (#7 OR #8 OR #9)
9. (#7 OR #8 OR #9)
10. (#6 AND #10)

EMBASE & CINAHL

Decubitus ulcer/decubitus ulcers
Spinal cord injury
Rehabilitation
Wound treatment
Lumbar support
Telerehabilitation
Telemedicine
Electrical stimulation
Maggot therapy
Education
Laser treatment
Ultrasound/ultraviolet C
Non-thermal pulsed electromagnetic energy treatment
Topical negative pressure therapy
Normothermic dressing
Recombinant human erythropoietin
Anabolic steroid agent
Bed positioning
Bed support surface
Wheelchair positioning
Wheelchair support surface
Nutrition

PUBMED

pressure ulcer AND spinal cord injury AND

- wound treatment
- lumbar support
- nutrition
- maggot therapy
- telerehabilitation
- electrostimulation
- education
- laser treatment
- ultraviolet c/ ultrasound
- non-thermal pulsed electromagnetic energy treatment
- topical negative pressure therapy
- normothermic dressing
- rehabilitation
- recombinant human erythropoietin
- anabolic steroid agents
- bed support surfaces
- bed positioning
- wheelchair support surfaces
- wheelchair positioning

B. PILOT TESTING SITES

Ontario Neurotrauma Foundation

Knowledge mobilization is a key mandate of the Ontario Neurotrauma Foundation, whose mission is

“to prevent the incidence and prevalence of neurotrauma and to improve the quality of life for those living with these injuries.”

The Ontario Neurotrauma Foundation funds Ontario-based, neurotrauma health research focused on evidence-based best practices that can move research into practice. The Ontario Neurotrauma Foundation will lead the pilot testing of these guidelines at the following sites.

KNOWLEDGE MOBILIZATION PROJECT

CENTRE	CONTACT
Ontario Neurotrauma Foundation 90 Eglinton Avenue East, Suite 601 Toronto, ON M4P 2Y3	Richard J Riopelle
Institut de réadaptation en déficience physique de Québec (IRD PQ) 525, boulevard Wilfrid-Hamel (Administration) Québec, QC, G1M 2S	Catherine Truchon
Institut de réadaptation Gingras-Lindsay-de-Montréal (IRGLM) 6300 Darlington Ave. Montreal, Quebec H3S 2J4	Vincent Tam Caroline Joly
Toronto Rehabilitation Institute University Health Network Lyndhurst Centre, Toronto Rehabilitation Institute 520 Sutherland Drive Toronto, ON M4G 3V9	Anthony S. Burns Heather Flett
St. Joseph's Health Care, Parkwood Hospital 801 Commissioners Road East London, ON N6C 5J1	Jane T.C. Hsieh Dalton Wolfe
Calgary Foothills Hospital 1403 29 Street NW Calgary, AB T2N 2T9	Raj Parmar Tammy Isaacs
Glenrose Rehabilitation Centre 10230 111 Avenue NW Edmonton, AB T5G 0B7	Cyndie Koning Barbara Stoesz

APPENDIX 2:

Impact of Spinal Cord Injury on the Body

A. NEUROANATOMY

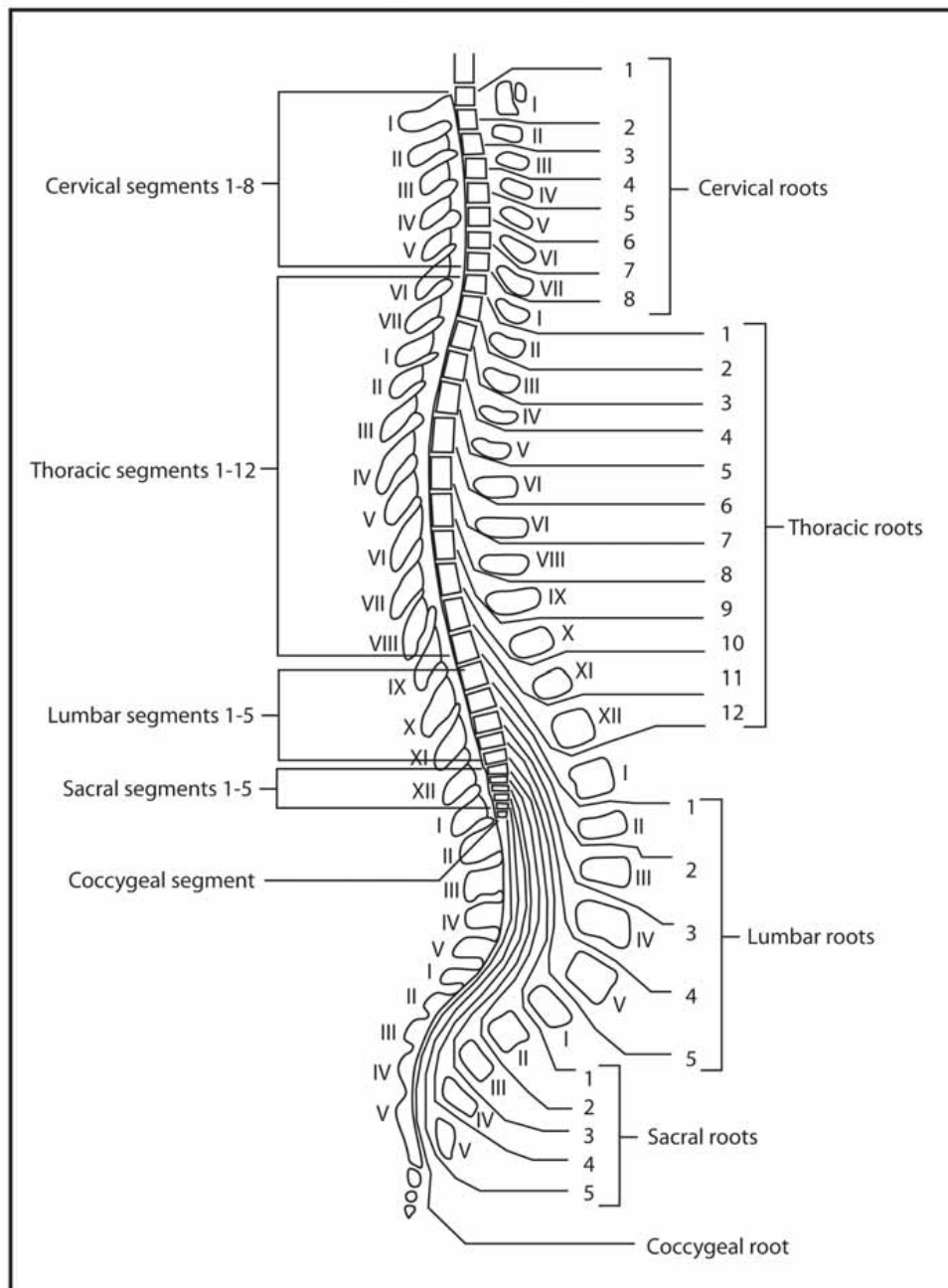

Figure 1. Relation between spinal cord segments, vertebral bodies, and spinal nerve roots

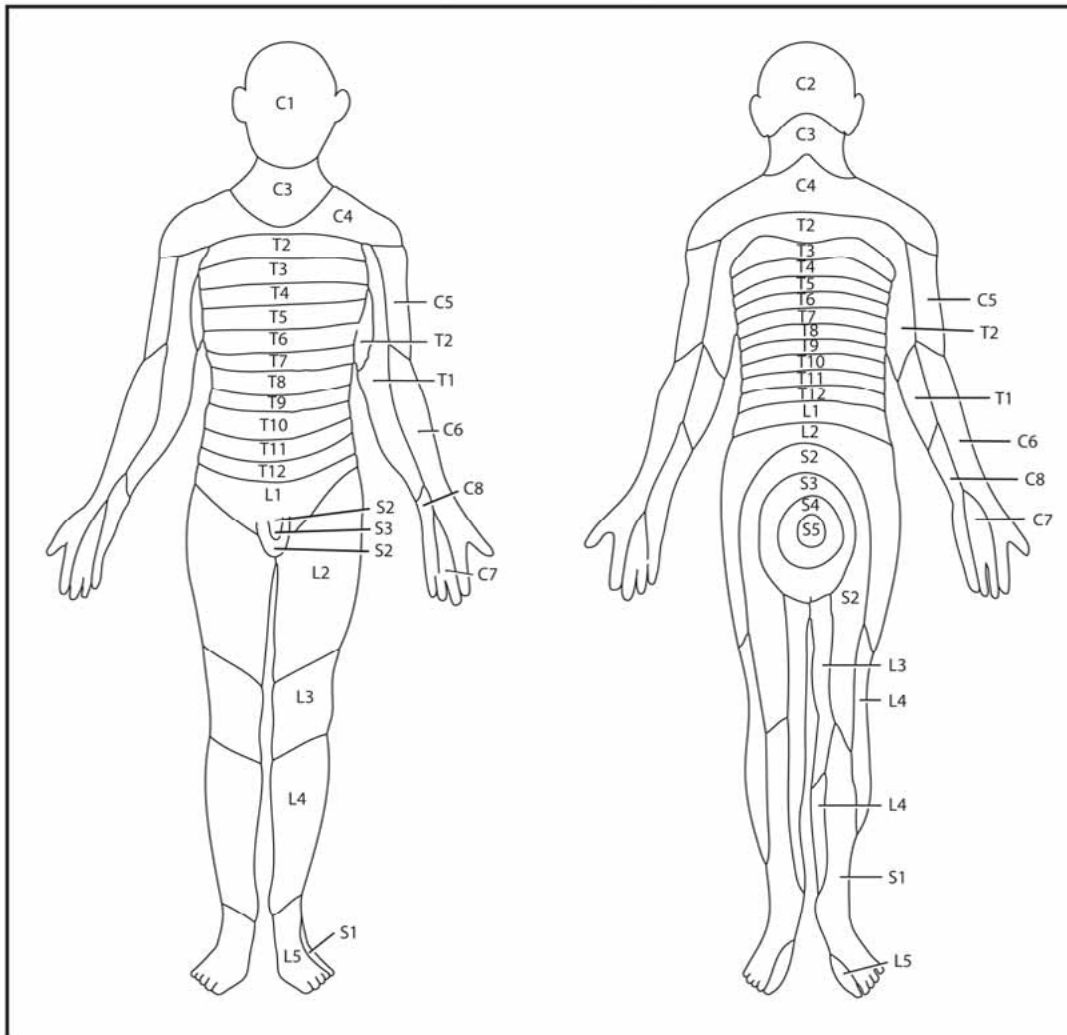

Figure 2. Dermatomes: sensory innervation

- C3,4,5: diaphragm
- C5: shoulder, elbow flexion
- C6: wrist flexion
- C7: elbow extension
- C8: finger flexion
- T1: spreads the fingers
- T1–T12: chest wall and abdominal muscles
- L2: hip flexion
- L3: knee extension
- L4: foot flexion
- L5: toe movement
- S1: foot extension
- S3,4,5: bladder, bowel, anus, genitals, pelvis

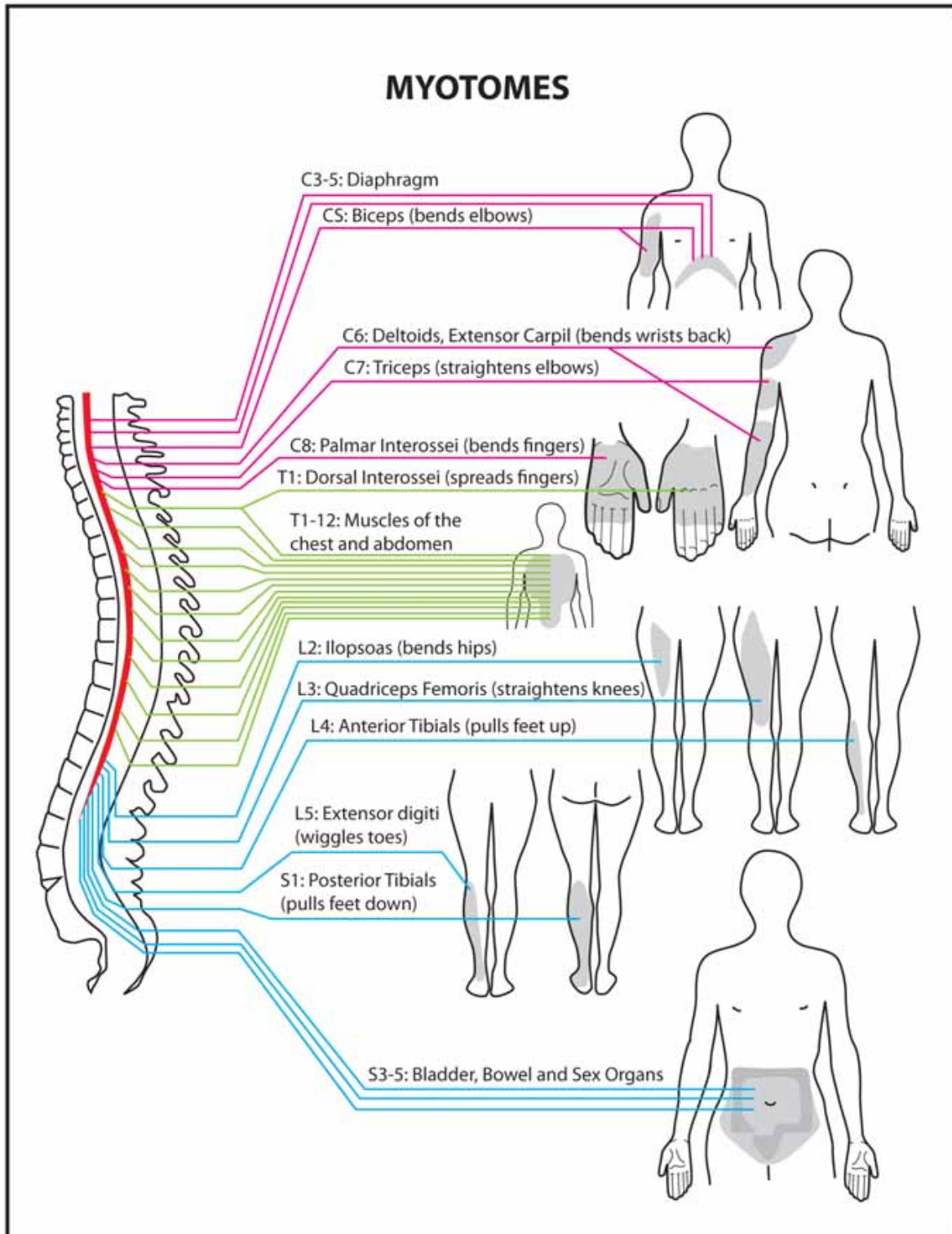

Figure 3. Myotomes. motor Innervation

B. AMERICAN SPINAL INJURY ASSOCIATION (ASIA) IMPAIRMENT SCALE

CLASSIFICATION	DESCRIPTION
A	COMPLETE No motor or sensory function is preserved below the level of injury, including the sacral segments S4–S5.
B	INCOMPLETE Sensory, but not motor, function is preserved below the neurologic level, with some sensation in the sacral segments S4–S5.
C	INCOMPLETE Motor function is preserved below the neurologic level. More than half of the key muscles below the neurologic level have a muscle grade less than 3/5 (i.e., not strong enough to move against gravity).
D	INCOMPLETE Motor function is preserved below the neurologic level, and at least half of the key muscles below the neurologic level have a muscle grade of 3 or more (i.e., joints can be moved against gravity).
E	NORMAL Motor and sensory functions are normal.

Used with permission. American Spinal Injury Association: International Standards for Neurological Classification of Spinal Cord Injury, revised 2011; reprinted 2011; Atlanta, GA.

C. TETRAPLEGIA AND PARAPLEGIA

Tetraplegia

Quadriplegia and tetraplegia are synonyms denoting weakness in the arms and legs. Paralysis means total weakness or absent motor function, whereas paresis means weakness and is the preferred definition given most patients with tetraplegia who have some motor function in their arms.

Note: The descriptions of available function by neurological level listed below are generalizations, and there are many differences between individuals at each level.

- C1 to C4 tetraplegia:
 - » C4 may have some shoulder function.
 - » Possibly requires artificial ventilation.
 - » Generally requires full-time caregiver support.
 - » May be able to use power wheelchair with chin or breath control.
- C5 tetraplegia:
 - » Elbow flexion present.
 - » Requires adaptive technology and caregiver support to perform activities of daily living.
 - » Can use power wheelchair with hand controls.
 - » Requires assistance for transfers and bladder and bowel management.

- C6 tetraplegia:
 - » Has motor function of elbow and wrist.
 - » Requires assistive devices to grasp objects.
 - » May be able to transfer independently.
 - » Requires some caregiver support at times.
- C7 tetraplegia:
 - » Elbow extension present.
 - » Can live independently and perform most activities of daily living, including transfers.
 - » May require assistive devices for tasks such as writing and telephoning.
- C8 tetraplegia:
 - » Finger flexion present, producing better grip.
 - » Can perform most activities of daily living independently.
 - » Can manage bladder and bowel care and transfer independently.
 - » Can use a manual wheelchair and perform tasks such as typing and answering the phone.

Paraplegia

- T1 to T12 paraplegia:
 - » Sensation and function present in arms typically allows functional independence.
 - » Sufficient torso control may be present to stand with support.
 - » Better torso control with T10 to T12 than T2 to T9 injury; may be able to walk short distances using walker or crutches.
 - » May frequently prefer wheelchair to prevent fatigue.
- Lumbar or sacral paraplegia:
 - » Functionally independent for all self-care and mobility.
 - » Can walk up to 150 feet, possibly with assistive devices.
 - » Generally needs wheelchair for longer distances.

 Consult the following resource for information about functional outcomes: Consortium for Spinal Cord Medicine. Outcomes following traumatic spinal cord injury. Clinical practice guidelines for healthcare professionals. 1999. Available at <http://www.metrohealth.org/documents/patient%20services/norscis/OutcomesFollowingSCI.pdf>. Accessed February 14, 2012.

D. AUTONOMIC DYSREFLEXIA

Injury at or above the splanchnic sympathetic outflow (T5–T6) disconnects sympathetic nerves below the neurologic level from those above it, producing autonomic dysreflexia. A strong sensory input produces a life-threatening, massive, and imbalanced reflex sympathetic discharge that affects the vasculature and organ systems with sympathetic innervation. The sympathetic nervous system dominates below the neurologic level, whereas the parasympathetic nervous system dominates above the level of injury.

This reflex sympathetic surge from the thoracolumbar sympathetic nerves causes widespread vasoconstriction and arterial hypertension that can result in stroke, seizures, or death. Carotid baroreceptor reflexes trigger inhibitory signals that reduce blood pressure and vagal impulses that produce compensatory bradycardia. These mechanisms, however, are inadequate to reduce blood pressure. Swift treatment is required to relieve the inciting stimulus.

Note: For a brief review of this topic, consult: Blackmer J. Rehabilitation medicine: 1. Autonomic dysreflexia. Can Med Assoc J 2003;169:931–5.

E. ANATOMIC AND PHYSIOLOGIC CHANGES AFTER SPINAL CORD INJURY

Pain

Most individuals with spinal cord injury experience some type and degree of pain that is affected by the level of injury. Generally, pain occurring at or above the neurologic level is nociceptive pain with a musculoskeletal or visceral cause. Neuropathic pain occurring within two dermatomes of the neurologic level may be central pain, due to spinal cord pathology; radicular pain, from the nerve roots; peripheral pain, from a compressive neuropathy; a complex regional pain syndrome; or sympathetic dystrophy. Below-level nociceptive musculoskeletal pain may occur in incomplete spinal cord injury or in complete injury where a zone of partial preservation exists. Below-level nociceptive visceral pain is vague and generalized in complete injury, although it may appear typical in people with incomplete spinal injury. At- or below-level neuropathic pain generally requires systemic combination pharmacotherapy for management, but identifying an effective and tolerable combination is a challenging task. Pressure ulcers are often associated with pain.

Bone

Osteoporosis, which occurs as a complication of spinal cord injury, affects mostly the pelvis and legs. It differs from other causes of bone loss due to disuse in several ways. The structural and metabolic changes associated with gravitational unloading in spinal cord injury are associated with a level of hypercalciuria two to four times greater than that seen in people on prolonged bed rest without spinal cord injury. Osteoclast activity levels are similar to those seen in postmenopausal osteoporosis, peaking at 10 weeks post injury. Neural factors associated with the injury, such as lack of traction by muscles, enhance bone loss. Parathyroid hormone levels increase significantly during the chronic phase after spinal cord injury, further increasing bone resorption.

Pathologic fracture is the most important complication of osteoporosis, with most fractures occurring in areas of greatest bone loss. The most common fracture sites are the supracondylar region of the femur and the proximal tibia. The Model Spinal Cord Injury System has recorded fracture rates at 5 years (14%), 10 years (18%), and 15 years (39%) post spinal cord injury.

Skeletal muscle

Spasticity, disuse atrophy, and decreased microvascular circulation are important features of paralyzed muscle. Although the major mechanism of muscle atrophy after spinal cord injury is disuse, functional properties of muscle fibres also begin to change soon after injury. Type 1 muscle fibres (slow twitch fibres with the ability to sustain aerobic activity) shift to type 2 (fast twitch fibres with a faster contractile speed). This transformation may be responsible for the muscle fatigability seen during functional electrical rehabilitation exercises. However, the fibre type changes are reversible with functional electrical rehabilitation, aerobic trainers, and biomechanical orthoses, suggesting the importance of early rehabilitation. Muscle atrophy reduces the natural protective cushioning effect that muscles provide over bony areas, increasing the risk of pressure ulcer formation.

Endocrine system

Muscle atrophy and inactivity after spinal cord injury produce body composition changes that promote development of metabolic syndrome, which is associated with abdominal obesity, insulin resistance, hyperinsulinemia, hyperglycemia, hypertension, and dyslipidemia. Metabolic syndrome is an important risk factor for both cardiovascular disease and diabetes, and both these conditions have an increased prevalence among people with spinal cord injury. Decreased levels of testosterone, somatotropin, and insulin-like growth factor-1 may exacerbate metabolic syndrome and decrease tissue repair, prolonging healing after injury. Thyroid abnormalities are also associated with spinal cord injury.

Body weight

Individuals with spinal cord injury have a high risk of obesity. Although the prevalence of obesity in the spinal cord injury population is unknown, a review of the currently available data suggests that approximately two-thirds of people with spinal cord injury are obese. One reason for the uncertainty is that prevalence estimates based on body mass index (BMI) underestimate obesity in people with spinal cord injury. BMI, originally a risk stratification tool for obesity-related disorders, does not distinguish between lean muscle mass and body fat. As a result, an athlete with a high BMI may have a very low body fat percentage, whereas an individual with spinal cord injury and a normal BMI is likely to have a body fat percentage in the obese range. In addition, research methods of determining body fat percentage are inaccurate in this population, due to physical and physiologic changes induced by spinal cord injury. Obesity is a risk factor for pressure ulcer development.

Cardiovascular system

Cardiovascular disease has been reported to have an incidence in people after spinal cord injury more than 200% greater than expected, based on matched populations. Premature cardiovascular disease is responsible for almost half of the mortality among individuals with spinal cord injury duration of at least 30 years. Ineffective tissue oxygenation reduces exercise tolerance, and both decreased sympathetic tone and absent pumping of the legs reduces venous return. Decreased tissue oxygenation may increase the risk of pressure ulcers.

Although little information is available on C-reactive protein (CRP) in relation to cardiovascular disease in this population, elevations of CRP in both acute and chronic spinal cord injury are found in association with other cardiovascular risk factors.

Skin

Denervation produces a variety of metabolic and physiologic changes affecting the skin in individuals with spinal cord injury. Dysregulation of metabolic and neural mechanisms that normally maintain adequate tissue blood flow profoundly affect all stages of wound healing. Vascular changes decrease the inflammatory phase of healing and reduce oxygen levels. A decrease in fibronectin reduces fibroblast activity and extracellular matrix formation. As a result, collagen synthesis decreases, and a reduction in collagen substrates leads to a change in the type of collagen formed. Large thick bundles of type I collagen predominate in the dermis, and small elastic type III collagen fibres decrease in the epidermis. These physiologic changes stemming from spinal cord injury may contribute to the difficulty in healing pressure ulcers in people with spinal cord injury.

Peripheral vascular perfusion

Cutaneous blood flow is reduced after spinal cord injury, and both regulation of cutaneous microcirculation and reaction to changes in local blood flow caused by intermittent changes in pressure are impaired. Several studies have documented reduced skin temperature and transcutaneous oxygen levels in the sacral region of people with spinal cord injury in comparison with age-matched controls. Cotie et al detected increased resting skin temperature and decreased skin temperature reactivity in the legs of people with spinal cord injury who were participating in supported standing.⁽¹⁾ These baseline levels of skin perfusion are further reduced with short periods of pressure loading, and the reactive hyperemia response to pressure in sacral skin blood flow is weaker.

Lungs

Respiratory muscle paralysis results in restrictive lung disease, with higher neurologic levels associated with greater restriction. With increasing duration of spinal cord injury, progressive spinal deformity and spasticity can worsen restriction. Hyperactive airway disease can also occur with a neurologic level of T6 or higher. Pulmonary dysfunction reduces tissue oxygenation, which is important for maintenance of tissue viability under applied pressure.

Immunity

Spinal cord injury depresses immune system function. Changes have been identified in the numbers and cytotoxicity of natural killer cells, function and activation of T cells, phagocytic activity of macrophages, and levels of several cytokines. Although no primary mechanism has been identified, autonomic dysregulation may be involved. Complications of spinal cord injury, such as diabetes, chronic pain, muscle wasting, and inactivity, may also have an impact.

These changes impair barrier function of skin and mucosal tissues, and opportunistic infections of the bladder, lungs, and skin are common. Asymptomatic bacteriuria, which is virtually universal in spinal cord injury, frequently leads to tissue invasion and recurrent urinary infection. Pressure ulcer infection may be complicated by cellulitis, osteomyelitis, septic arthritis, or abscess. People with spinal cord injury have an increased risk of secondary pneumonia after respiratory infections. Infection may be complicated by bacteremia; the urinary tract and infected pressure ulcers are the most common sources.

Aging

In all body systems, spinal cord injury hastens the physical decline and functional loss associated with aging. Several long-term studies have documented accelerated aging in individuals with spinal cord injury, beginning between 10 and 20 years after injury, depending on factors such as age at injury. Individuals injured at a younger age are expected to have a longer duration of functional stability than those injured later in life. People with spinal cord injury experience functional decline in major life areas at a much younger age than individuals without spinal cord injury.

An important clinical implication of accelerated aging is its impact on age as a pressure ulcer risk factor. Chronological age in people with spinal cord injury may significantly underestimate physiologic age.

References

- ¹¹ Cotie LM, Geurts CL, Adams MM, MacDonald MJ. Leg skin temperature with body-weight-supported treadmill and tilt-table standing training after spinal cord injury. *Spinal Cord* 2011 Jan;49(1):149-153.

Useful resources

- Young W. Spinal cord injury levels and classification. Available at <http://wiseyoung.wordpress.com/>. Accessed January 26, 2011.
- Spinal cord anatomy. Apparelyzed Spinal Cord Injury Support Network. Available at <http://www.apparelyzed.com/>. Accessed December 5, 2010.
- Handbook of Spinal Cord Injuries, 2nd Edition. Queensland Spinal Cord Injuries Service, Princess Alexandra Hospital District Health Service, Brisbane, Queensland, Australia. Available at <http://www.health.qld.gov.au/>. Accessed December 5, 2010.
- ASIA Standard neurological classification of spinal cord injury. Available at http://www.asia-spinalinjury.org/publications/59544_sc_Exam_Sheet_r4.pdf. Accessed April 29, 2011.
- Levels of spinal cord injury. Available at http://www.brainandspinalcord.org/content/levels_of_spinal_cord_injury. Accessed December 5, 2010.
- International standards for neurological classification of spinal cord injury. Available at http://www.asia-spinalinjury.org/publications/59544_sc_Exam_Sheet_r4.pdf. Accessed February 12, 2012.
- Campagnolo DI. Autonomic dysreflexia in spinal cord injury. Available at <http://www.emedicine.medscape.com/>. Accessed December 10, 2010.
- Consortium for Spinal Cord Medicine clinical practice guideline. Acute management of autonomic dysreflexia: individuals with spinal cord injury presenting to health-care facilities, 2nd edition. Paralyzed Veterans of North America. 2001. Available at <http://www.pva.org>. Accessed February 12, 2012.

APPENDIX 3:

National Pressure Ulcer Advisory Panel: International Pressure Ulcer Classification System 2009

Used with permission. European Pressure Ulcer Advisory Panel and National Pressure Ulcer Advisory Panel. *Treatment of pressure ulcers: Quick Reference Guide*. Washington DC: National Pressure Ulcer Advisory Panel; 2009. Available at <http://www.npuap.org>. Accessed June 25, 2012.

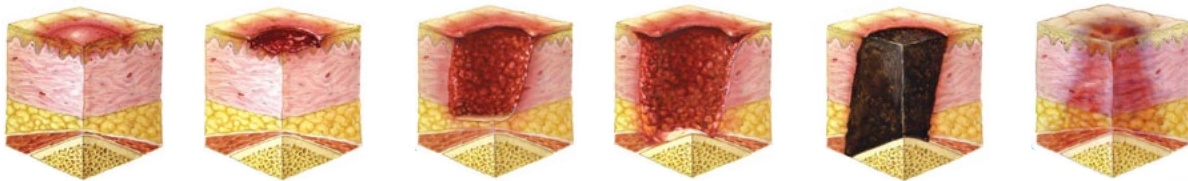

Stage I: Non-blanchable erythema

- Intact skin, non-blanchable localized redness, especially over a bony prominence
- Area may be painful, firm, or soft, or warmer or cooler than adjacent tissue
- May indicate 'at-risk' individuals
- May be difficult to detect on dark skin

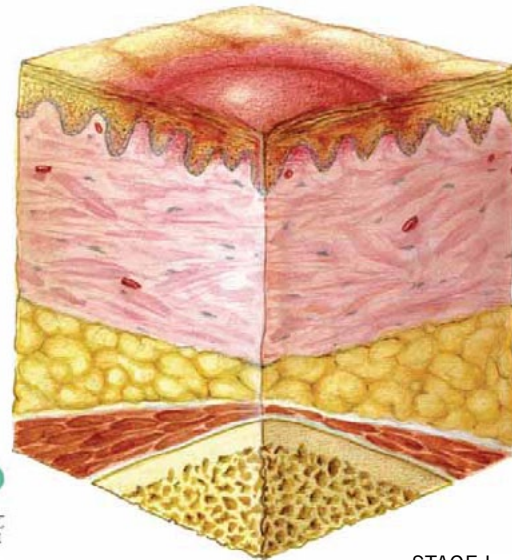

STAGE I

Stage II: Partial-thickness skin loss

- Shallow open ulcer, red-pink wound bed, no slough
- Possibly intact or open or ruptured serum-filled or serosanguinous blister presenting as shiny or dry shallow ulcer without slough or bruising, which indicates deep tissue injury
- Does not include skin tears, tape burns, incontinence-associated dermatitis, maceration or excoriation

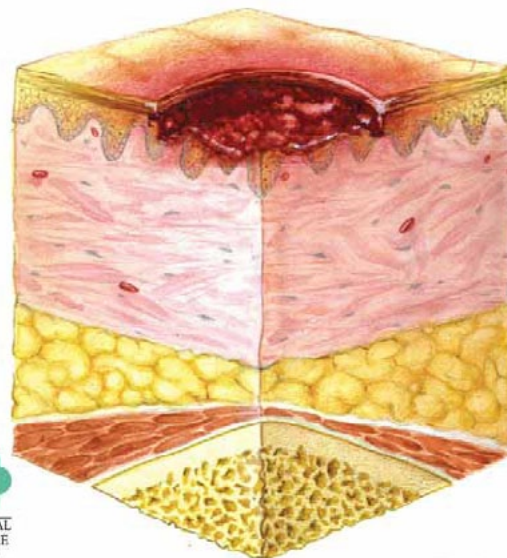

STAGE 2



NATIONAL
PRESSURE
ULCER
ADVISORY
PANEL



NATIONAL
PRESSURE
ULCER
ADVISORY
PANEL

Stage III: Full-thickness skin loss

- Subcutaneous fat may be visible
- Bone, tendon or muscle not exposed or directly palpable
- May be present: slough that does not obscure depth of tissue loss, undermining, tunnelling
- Depth varies by anatomy:
 - » Bridge of nose, ear, occiput, and malleolus do not have adipose subcutaneous tissue: ulcers may be shallow
 - » Areas of significant adiposity can have very deep ulcers

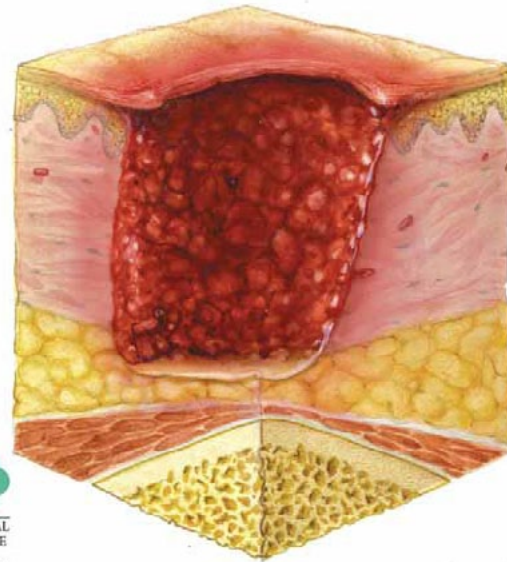

STAGE 3

Stage IV: Full thickness tissue loss

- Exposed bone, tendon or muscle visible or directly palpable
- Slough or eschar may be present
- Often includes undermining and tunnelling
- Depth varies by anatomy:
 - » Bridge of nose, ear, occiput, and malleolus do not have adipose subcutaneous tissue: ulcers may be shallow
- May extend into muscle and supporting structures, such as fascia, tendon, or joint capsule, making osteomyelitis or osteitis a risk

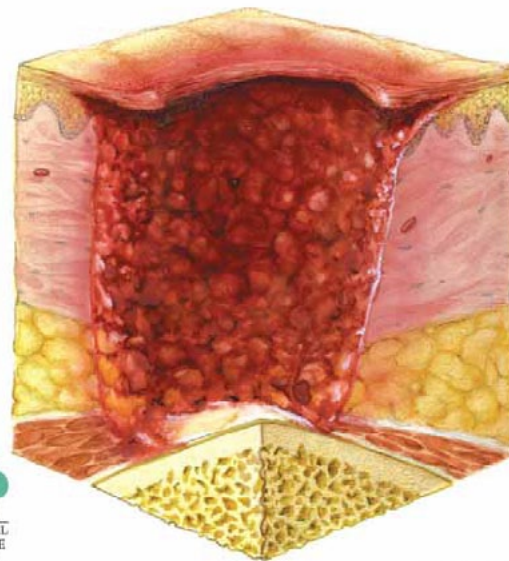

STAGE 4

Unstageable or unclassified

Full-thickness skin or tissue loss: depth unknown

- Wound bed obscured by yellow, tan, gray, green, or brown slough and/or tan, brown, or black eschar
- Depth cannot be determined until slough and/or eschar are removed to expose wound base, but category III or IV once clean
- Note: stable, dry, adherent eschar on heels that is intact without erythema or fluctuance is natural biological cover and should not be removed



NATIONAL
PRESSURE
ULCER
ADVISORY
PANEL



UNSTAGEABLE

Suspected deep tissue injury

- Depth unknown
- Purple or maroon localized discoloured area of intact skin or blood-filled blister
- Due to underlying soft tissue damage from pressure and/or shear
- Discolouration may be preceded by painful, firm, mushy, or boggy tissue that is warmer or cooler than adjacent tissue
- May be difficult to detect in individuals with dark skin
- May develop into thin blister over dark wound bed followed by thin eschar
- May develop rapidly, exposing additional tissue layers, even with optimal treatment



NATIONAL
PRESSURE
ULCER
ADVISORY
PANEL

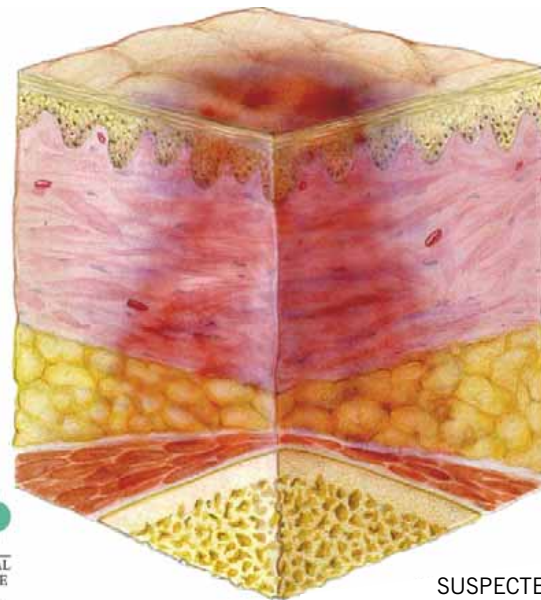

SUSPECTED
DEEP TISSUE INJURY

APPENDIX 4:

Support Surfaces

A. TERMS AND DEFINITIONS RELATED TO SUPPORT SURFACES 2007

National pressure ulcer advisory panel support surfaces standards initiative

Used with permission: National Pressure Ulcer Advisory Panel Support Surfaces Initiative. Terms and Definitions Related to Support Surfaces. Version 01/29/2007. Available at http://www.npuap.org/NPUAP_S3I_TD.pdf. Accessed December 1, 2010.

Physical concepts related to support surfaces

Friction (frictional force): The resistance to motion in a parallel direction relative to the common boundary of two surfaces

Coefficient of friction: A measurement of the amount of friction existing between two surfaces

Envelopment: The ability of a support surface to conform, so as to fit or mold around irregularities in the body

Fatigue: The reduced capacity of a surface or its components to perform as specified. This change may be the result of intended or unintended use and/or prolonged exposure to chemical, thermal, or physical forces

Force: A push—pull vector with magnitude (quantity) and direction (pressure, shear) that is capable of maintaining or altering the position of a body

Immersion: Depth of penetration (sinking) into a support surface

Life expectancy: The defined period of time during which a product is able to effectively fulfill its designated purpose

Mechanical load: Force distribution acting on a surface

Pressure: The force per unit area exerted perpendicular to the plane of interest

Pressure redistribution: The ability of a support surface to distribute load over the contact areas of the human body. This term replaces prior terminology of pressure reduction and pressure relief surfaces.

Pressure reduction: This term is no longer used to describe classes of support surfaces. The term is pressure redistribution; see above.

Pressure relief: This term is no longer used to describe classes of support surfaces. The term is pressure redistribution; see above.

Shear (shear stress): The force per unit area exerted parallel to the plane of interest

Shear strain: Distortion or deformation of tissues as a result of shear stress

Components of support surfaces

Note: Components of any support surface may be used alone or in combination

Air: A low-density fluid with minimal resistance to flow

Cell (bladder): A means of encapsulating a support medium

Viscoelastic foam (memory foam): A type of porous polymer material that conforms in proportion to the applied weight. The air exits and enters the foam cells slowly, which allows the material to respond more slowly than standard elastic foam.

Elastic foam (non-memory foam): A type of porous polymer material that conforms in proportion to the applied weight. Air enters and exits the foam cells more rapidly, due to greater density.

Closed-cell foam: A non-permeable structure in which there is a barrier between cells, preventing gases or liquids from passing through the foam.

Open-cell foam: A permeable structure in which there is no barrier between cells and gases or liquids can pass through the foam.

Gel: A semisolid system consisting of a network of solid aggregates, colloidal dispersions or polymers, which may exhibit elastic properties. (Can range from hard to soft gel)

Pad: A cushion-like mass of soft material used for comfort, protection or positioning.

Viscous fluid: A fluid with a relatively high resistance to flow of the fluid.

Elastomer: Any material that can be repeatedly stretched to at least twice its original length; upon release the stretch will return to approximately its original length.

Solid: A substance that does not flow perceptibly under stress. Under ordinary conditions retains its size and shape.

Water: A moderate-density fluid with moderate resistance to flow.

Features of support surfaces

A feature is a functional component of a support surface that can be used alone or in combination with other features

Air fluidized: A feature of a support surface that provides pressure redistribution via a fluid-like medium created by forcing air through beads, as characterized by immersion and envelopment

Alternating pressure: A feature of a support surface that provides pressure redistribution via cyclic changes in loading and unloading as characterized by frequency, duration, amplitude, and rate-of-change parameters

Lateral Rotation: A feature of a support surface that provides rotation about a longitudinal axis as characterized by degree of patient turn, duration, and frequency.

Low air loss: A feature of a support surface that provides a flow of air to assist in managing the heat and humidity (microclimate) of the skin.

Zone: A segment with a single pressure redistribution capability.

Multi-zoned surface: A surface in which different segments can have different pressure redistribution capabilities

Categories of support surfaces

Reactive: A powered or non-powered support surface with the capability to change its load distribution properties only in response to applied load

Active: A powered or non-powered support surface with the capability to change its load distribution properties, with or without applied load

Integrated bed system: A bed frame and support surface that are combined into a single unit, whereby the surface is unable to function separately

Non-powered: Any support surface not requiring or using external sources of energy for operation

Powered: Any support surface requiring or using external sources of energy (AC/DC) to operate

Overlay: An additional support surface designed to be placed directly on top of an existing surface

Mattress: A support surface designed to be placed directly on the existing bed frame

B. SUPPORT SURFACE SELECTION TOOL

THERAPEUTIC SUPPORT SURFACES

Figure 1: Therapeutic Support Surfaces Selection Tool

		VALIDATED RISK ASSESSMENT CATEGORY OR PRESSURE ULCER DESCRIPTION			
		AT RISK or Redness present which fades quickly when pressure removed	MODERATE RISK or One pressure ulcer (excluding the heels) where the client can be positioned off the ulcer	HIGH RISK or One pressure ulcer (excluding the heels) and redness over another area	VERY HIGH RISK or Multiple pressure ulcers (excluding the heels) or the client can not be positioned off of an ulcerated area
Ability to change position in bed (i.e. bed mobility)	Total assist to change position in bed	Reactive Support Surface (non powered) (e.g. air/gel/foam overlay)	Reactive Support Surface (e.g. air/gel/foam overlay)	Active Support Surface (e.g. alternating pressure mattress, rotational surface) or a Powered Reactive Support Surface (e.g. low air loss)	Active Support Surface Multi-Zoned Surface (e.g. alternating pressure mattress, rotational surface)
	Moderate assistance with bed mobility required	Reactive Support Surface (non powered) (e.g. air/gel/foam overlay or high density foam mattress)	Reactive Support Surface (e.g. foam overlay with air section insert in the area of the wound)	Reactive Support Surface (non powered) (e.g. foam overlay with air section insert in the area of the wound)	Active Support Surface Multi-Zoned Surface (e.g. alternating pressure mattress, rotational surface)
	Client independent with or without a device with bed positioned (light assist may be required)	Reactive Support Surface (e.g. high density foam mattress)	Reactive Support Surface (e.g. foam overlay with air section insert)	Reactive Support Surface (non powered) (e.g. air/gel/foam overlay)	Powered Reactive Support Surface (e.g. low air loss – if the controls can be placed within the client's reach)

Used with Permission. Norton, Coultts, Sibbald, 2011 ©

C. REACTIVE SUPPORT SURFACE SELECTION TOOL

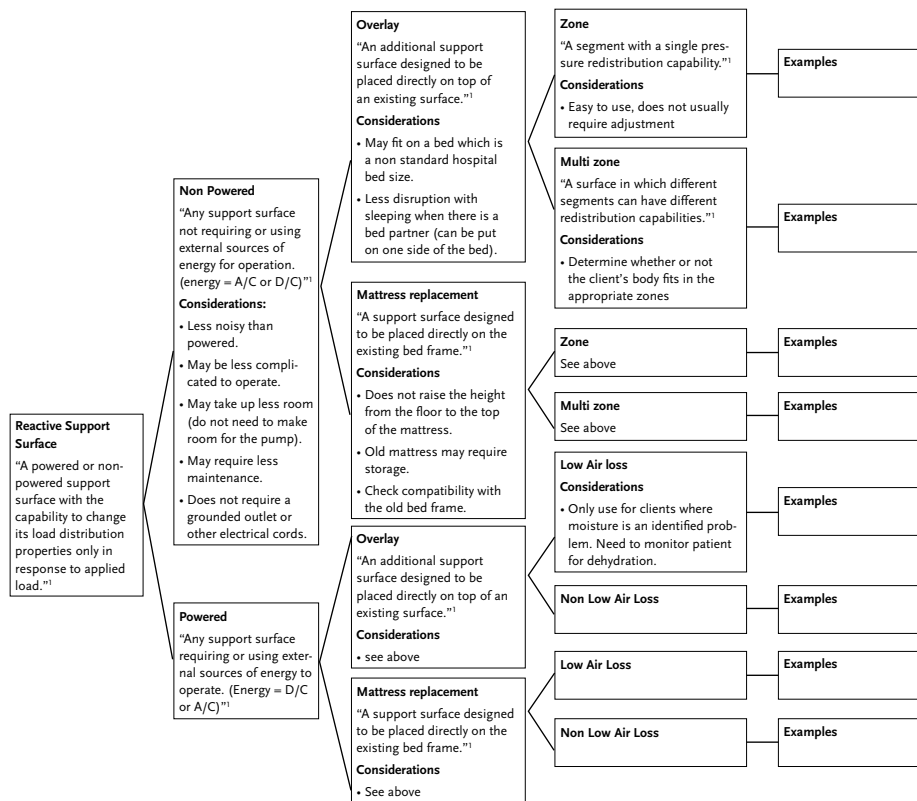

Used with Permission. Norton, Coultts, Sibbald, 2011 ©

D. ACTIVE SUPPORT SURFACE SELECTION TOOL

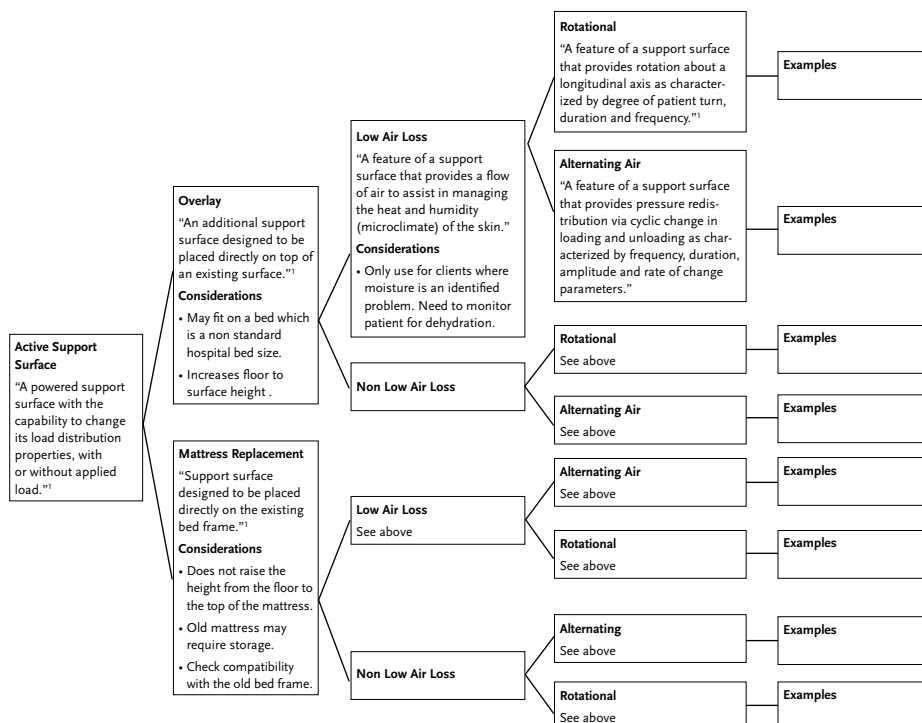

Used with Permission. Norton, Coultts, Sibbald, 2011 ©

APPENDIX 5:

Graduated Sitting Protocol for Pressure Ulcer Management

Perform a skin check prior to sitting at all times
Perform a skin check post sitting at all times

1st day sitting - client can sit up for **15 minutes BID**

- If skin condition does not deteriorate after 1st day, increase sitting time as outlined below
- If skin condition does deteriorate after 1st sitting, return to bed rest until re-evaluated by medical staff

NOTE: ONCE CLIENT PROGRESSES PAST 1ST DAY SITTING, IT IS RECOMMENDED THAT A PRESSURE RELIEVING MOVEMENT OCCURS EVERY 15-20 MIN (3-4X/HOUR) WHILE SITTING UP

2nd day sitting – client can sit up for **30 min BID**

- If skin condition does not deteriorate after 2nd day, increase sitting time as outlined below
- If skin condition does deteriorate after 2nd sitting, return to 15 min sitting only

3rd day sitting – client can sit up for **1hr BID**

- If skin condition does not deteriorate after 3rd day, increase sitting time as outlined below
- If skin condition does deteriorate after 3rd sitting, return to 30 min sitting only

4th day sitting – client can sit for **2 hrs BID**

- If skin condition does not deteriorate after 4th day, increase sitting time as outlined below
- If skin condition does deteriorate after 4th sitting, return to 1 hr sitting only

SIT TIMES CAN CONTINUE TO PROGRESS ON EACH OCCASION BY DOUBLING THE OVERALL LENGTH OF TIME UP FROM THE PREVIOUS TRIAL AS LONG AS SKIN CHECKS DEMONSTRATE NO NEW PRESSURE-RELATED PROBLEMS

*Rehabilitation Day Program Specialized Seating Service, Health Sciences Centre, Winnipeg, Manitoba
Used with permission. ©Jennifer Birt 2009*

APPENDIX 6:

Levine Method for Wound Swab for Culture and Sensitivity



South West Regional Wound Care Toolkit



Levine Method for wound swab for culture & sensitivity ^{i,ii,iii.}

- The Ontario Laboratories Act requires a health care practitioner's order to process the culture
- Use sterile cotton tipped swab and culture medium in a pre-packaged collection and transport system
- For visiting nurses, do not allow transport medium to freeze or become overheated in your car before using it.
- If both anaerobic and aerobic cultures are desired, ensure that the swab kit has this capability and that you have requested both tests in the order
- Thoroughly rinse wound with normal saline (non-bacteriostatic). If this is a cavity wound and you will be swabbing tissue at the bottom of the cavity, blot any excess NS with a sterile gauze to prevent dilution of the sample; if the wound is quite dry you should pre-moisten the swab in the culture medium before pressing on the tissue.
- Don't swab pus, exudate, hard eschar or necrotic tissue. If there is no healthy granulation tissue present, there is no point in swabbing the wound as the results will only tell you what is on the surface, not what is actually in the live (viable) tissue
- Rotate the swab tip in a 1 cm square area of clean granulation tissue for a period of 5 seconds, using gentle pressure to release tissue exudate. This may cause discomfort so prepare the client/patient of the possibility
- Remove protective cap from culture medium and insert cotton tipped applicator into the culture medium without contaminating the applicator shaft
- Follow hospital or institutional practices for getting the swab to the lab. DO NOT REFRIGERATE! In the community sector, the patient or their family/care providers should transport the specimen to the laboratory at room temperature within 24 hours. Within one hour is ideal...the sooner the better.

ⁱHarris, C. Care Partners/ET NOW. (2000) Clinical Practice Policy and Procedure 16.2.3. Semi Quantitative Wound Swab Sample Culturing Technique. Used with permission.

ⁱⁱDow, G., Browne, A., & Sibbald, G., (1999). Infection in Chronic Wounds: Controversies in Diagnosis and Treatment. *Ostomy/Wound Management*, 45⁽⁹⁾:23-40.

ⁱⁱⁱStotts, N. (1995). Determination of Bacterial Bioburden in Wounds. *Advances in Wound Care*, 8⁽⁴⁾ 28-46.

APPENDIX 7:

Mobilization Protocol After Flap Surgery

Used with permission from Vancouver Coastal Health.

MOBILIZATION POST-FLAP SURGERY

(NOTE: this is only a general guideline and not every client follows it exactly)

- Mobilization (sitting up in bed and getting into your wheelchair) starts 2 weeks after surgery if there are no open areas on the incision line.
- If there is skin breakdown (i.e., an open area on the incision line, or redness), then mobilization will be delayed until the open area starts to heal (i.e., smaller and less drainage).
- Check with MD and/or WOCN (Wound Nurse) for readiness to mobilize.
- Nursing, OT and PT are involved with mobilization, as well as reviewing transfers and equipment.
- PT may provide upper extremity strengthening program.

POST-OP DAY	ACTIVITY LEVEL
Date initiated: _____ Day 15	<ul style="list-style-type: none"> ■ Transfer client to an appropriate mattress as specified by the plastic surgeon or WOCN. ■ Regular turning schedule while in bed (every 2-3 hours) is crucial for wound healing. <p style="text-align: center;">↓</p> <p style="text-align: center;">If no skin breakdown, progress to next level</p>
Date initiated: _____ Day 16 & 17	<ul style="list-style-type: none"> ■ HOB (Head of Bed) at 45° for meals only. ■ Check flap for skin breakdown (new redness, discoloration or open area) immediately after meals and 1 hour after meals. ■ If there is breakdown on the flap, hold mobilization and go back to previous level. <p style="text-align: center;">↓</p> <p style="text-align: center;">If no skin breakdown, progress to next level</p>
Date initiated: _____ Day 18 & 19	<ul style="list-style-type: none"> ■ HOB to 90° for all meals. ■ Client and nurse check flap after meals (as above). <p style="text-align: center;">↓</p> <p style="text-align: center;">If no skin breakdown, progress to next level</p>
Date initiated: _____ Day 20-22	<ul style="list-style-type: none"> ■ Sit up on edge of bed for 10 minutes twice per day with Nursing/OT/PT supervision. ■ Client and nurse continue to check flap for breakdown after each activity. ■ Reassess turning schedule with team. <p style="text-align: center;">↓</p> <p style="text-align: center;">If no skin breakdown, progress to next level</p>
Date initiated: _____ Day 23-26	<ul style="list-style-type: none"> ■ Mobilize to wheelchair 5-10 minutes twice per day with OT/PT/Nursing supervision. ■ Increase time up by 5 minutes each day – if no new skin breakdown. ■ Client and team begin to plan for upcoming discharge (i.e., attendant care and equipment readiness). <p style="text-align: center;">↓</p> <p style="text-align: center;">If no skin breakdown, progress to next level</p>
Date initiated: _____ Day 27-29	<ul style="list-style-type: none"> ■ Up in wheelchair for 30 minutes twice per day. ■ Increase time up by 10 minutes each day – if no skin breakdown. ■ Goal is to be up for 60 minutes twice per day in wheelchair. ■ Client and team to make specific plans for discharge home and set a date. <p style="text-align: center;">↓</p> <p style="text-align: center;">If no skin breakdown, progress to next level</p>
Date initiated: _____ Day 30	<ul style="list-style-type: none"> ■ Increase time up by 15 minutes each day – if no skin breakdown. ■ Client should be up in wheelchair a minimum of 4 hours twice/ day prior to discharge (total 8 hours). <p style="text-align: center;">↓</p> <p style="text-align: center;">If no skin breakdown, progress to next level</p>

APPENDIX 8:

Specialized Assessment Forms

A. PHYSIOTHERAPY ASSESSMENT FORM

Used with permission from Parkwood Hospital.

 Parkwood Hospital PHYSIOTHERAPY DATA BASE	Client Name
	Medical Record Number
	Date

N=NORMAL ADEQUATE FUNCTION

A=ABNORMAL INADEQUATE FUNCTION

XE=NOT EVALUATED

DIAGNOSIS/REASON FOR REFERRAL

DATE OF INITIAL PHYSIOTHERAPY INTERVENTION

CONSENT

HISTORY/PATIENT PROFILE

- History of present illness
- Past medical history
- Social history – including living arrangements, social supports, funding sources, home/work environment

SUBJECTIVE DATA

- Goals, concerns, pain complaints

N A XE OBSERVATION OF FACTORS AFFECTING PATIENT RESPONSE:

ORIENTATION

- Orientation x 3

STATE OF MIND

- Depression, anxiety, motivation, cooperation, behavioral concerns

COMMUNICATION

- Receptive/expressive abilities
- Language barriers

- VISION
- Acuity issues, field deficits, neglect

MEDICATIONS

- SPECIFIC PHYSICAL EVALUATIONS:

- OBSERVATIONS
- General appearance related to health, physical stature

- CARDIOPULMONARY SYSTEM
- Smoking history
- Detailed assessment (inspection, palpation, auscultation, percussion)
- Respiratory/ventilatory issues
- Circulatory/cardiac issues

- SKIN CONDITION
- Wound history
- Current integrity issues – location, possible cause, restriction
- General skin condition/health

- SENSATION/PAIN
- Pain – location, characteristics, behaviour, impact on function
- Cutaneous/proprioceptive sensation

- ARTICULAR/FLEXIBILITY
- Contractures, deformities, muscle imbalances
- Special attention to 2-joint muscles

- REFLEXES AND TONE
- Abnormal reflex activity
- Associated reactions/movements
- Abnormal muscle ton
- Acceptance of base of support

- MUSCULAR/MOTOR/COORDINATION
- Motor control – selectivity, recruitment, imbalances
- Muscle strength
- Coordination

- FUNCTIONAL ABILITY:

- SWALLOWING
- Dietary concerns/nutrition
- Oral-motor control

BALANCE/POSTURE/SEATING

- Current wheelchair/seating equipment
- Postural alignment in relevant postural sets – special attention to pelvic alignment, spinal curves, range/flexibility to support proper positioning
- Postural control/protective responses in relevant postural sets
- Objective measures (e.g., Berg Balance Score, Activities-specific Balance Confidence Scale, Best Test, - Community Balance and Mobility Scale)

 GROSS MOTOR ACTIVITIES/GAIT

- Bed mobility: In lying – rolling, bridging, scooting, shifting, LE management
In high/long-sitting – shifting, scooting, lifts, LE management
- Transitional movements: Lie ↔ Long sitting/tailor sit ↔ high sitting
Sit ↔ stand
- Transfers – to all functionally-significant surfaces (e.g., w/c ↔ mat, w/c ↔ bed, tub/toilet transfers, w/c ↔ car, w/c ↔ floor)
 - » Type, level of assistance for sub-tasks (e.g., positioning of w/c, brake management, movement/repositioning within w/c, placement of slide board)
- Mobility: Wheelchair use – method of propulsion, basic/advanced skills including offloading and pressure-redistribution methods
Ambulation – gait pattern, aids, assistance, distance
- Objective measures (e.g., Spinal Cord Independence Measure, Timed Up and Go, 2-minute walk test, 6 minute walk test, 10 meter test)

 ACTIVITY TOLERANCE

- Tolerance for activities of daily living (e.g., self-care, IADL, sitting tolerance, walking tolerance, exercise tolerance, leisure activities) – reason for limitation
- Objective measures (e.g., Modified Fatigue Severity Scale, BORG score associated with specific activities)

OTHER FINDINGS:

- Daily routine (e.g. time spent in bed, rest requirements, nighttime turning routine)
- Personal care needs
- Sleep pattern
- Sleep position/surface
- Bowel/bladder management/continence

ANALYSIS:

KEY IMPAIRMENTS:

CLINICAL IMPRESSIONS:

GOALS:

PLAN:

Review Date:

Signature:

B. PRESSURE MANAGEMENT ASSESSMENT TOOL

Used with permission from Jennifer Birt

Pressure Management Assessment Tool (PMAT)

Client: _____ Date: _____

Part One - Interview:

PRESSURE ULCER HISTORY:

(A) CURRENT PRESSURE ULCERS:

Where is (are) your pressure ulcer(s) currently located? Check all that apply.

LOCATION	YES		NO	LIKELY CAUSE	LENGTH OF TIME WITH ULCER	HAS ULCER DETERIORATED OR IMPROVED SINCE STARTING?
	Right	Left				
Ischial tuberosity (buttock bone)	<input type="checkbox"/>	<input type="checkbox"/>				
Greater trochanter (hip bone)	<input type="checkbox"/>	<input type="checkbox"/>				
Coccyx (Tailbone)						
Sacrum (above tailbone)						
Heel	<input type="checkbox"/>	<input type="checkbox"/>				
Other areas of lower limb <i>Describe:</i>	<input type="checkbox"/>	<input type="checkbox"/>				
Elbow	<input type="checkbox"/>	<input type="checkbox"/>				
Scapula (shoulder blade)	<input type="checkbox"/>	<input type="checkbox"/>				

PMAT developed by Jennifer Birt, OT Reg (MB), Specialized Seating and Mobility Clinical Specialist
Rehabilitation Day Program Specialized Seating Service, Health Sciences Centre, Winnipeg, Manitoba

Client: _____ Date: _____

(B) PREVIOUS PRESSURE ULCERS:

Have you ever had other pressure sores in the past? YES ____ NO ____

If YES, please indicate previous location of ulcer(s) from below:

LOCATION	YES		NO	LIKELY CAUSE	LENGTH OF TIME WITH ULCER	METHOD USED TO HEAL ULCER
	Right	Left				
Ischial tuberosity (buttock bone)	<input type="checkbox"/>	<input type="checkbox"/>				
Greater trochanter (hip bone)	<input type="checkbox"/>	<input type="checkbox"/>				
Coccyx (Tailbone)						
Sacrum (above tailbone)						
Heel	<input type="checkbox"/>	<input type="checkbox"/>				
Other areas of lower limb <i>Describe:</i>	<input type="checkbox"/>	<input type="checkbox"/>				
Elbow	<input type="checkbox"/>	<input type="checkbox"/>				
Scapula (shoulder blade)	<input type="checkbox"/>	<input type="checkbox"/>				

PMAT developed by Jennifer Birt, OT Reg (MB), Specialized Seating and Mobility Clinical Specialist
Rehabilitation Day Program Specialized Seating Service, Health Sciences Centre, Winnipeg, Manitoba

Client: _____ Date: _____

PRESSURE ULCER FACTORS:

(A) PHYSICAL STATUS:

1. What is your medical diagnosis?
2. Do you have any additional medical conditions? YES ____ NO ____
If YES, please describe:
3. Do you have full sensation? YES ____ NO ____
If NO, please describe where and how your sensation is impaired.
4. Do you smoke? YES ____ NO ____
If YES, how much do you smoke?
5. Do you have spasticity? YES ____ NO ____
If NO, please proceed to question 6

If YES, please complete the following questions:

What part(s) of your body moves when you experience spasms?

What types of things trigger your spasms to occur?

Do your spasms make it difficult for you to stay positioned properly in any of the following situations? Check all that apply:

- lying in bed
- sitting in your wheelchair
- sitting on your toilet or commode
- sitting in your bathtub or on a bathseat
- travelling in a vehicle
- during transfers
- during wheelchair propulsion
- driving a power mobility device

What do you do to help your spasms stop once they occur?

Do you take medication to help reduce your spasms? YES ____ NO ____

If YES, please list medication and dosage:

PMAT developed by Jennifer Birt, OT Reg (MB), Specialized Seating and Mobility Clinical Specialist
Rehabilitation Day Program Specialized Seating Service, Health Sciences Centre, Winnipeg, Manitoba

Client: _____ Date: _____

If NO, are there any medications you tried previously to help reduce spasms? YES ____ NO ____
Please list the medication(s) you previously tried and indicate the reason for discontinuing its use

(B) NUTRITION:

1. Have you been seen by a dietitian since developing your current pressure sore(s)? YES ____ NO ____
If NO, have you ever been seen by a dietitian in the past?
YES ____ NO ____
2. Please describe the types of food and drink that typically make up each meal and snack you eat throughout the day:
3. Please describe your normal eating and drinking patterns – when do you usually eat your meals and snacks throughout the day?

(C) BED and MATTRESS:

1. How many hours do you spend in bed on an average day? _____ hrs/day
2. Do you stay in bed this entire time without a break? YES ____ NO ____
If NO, describe how you break up your time in bed over a 24 hr period:
3. What type of bed and mattress do you use?

BED:

MATTRESS:
4. How many times do you change between different positions in bed?

PMAT developed by Jennifer Birt, OT Reg (MB), Specialized Seating and Mobility Clinical Specialist
Rehabilitation Day Program Specialized Seating Service, Health Sciences Centre, Winnipeg, Manitoba

Client: _____ Date: _____

5. Do you position yourself in any of the following ways in bed?

Position	Yes	No	Describe what your body looks like in this position	Equipment used
On your back <i>without</i> the head of the bed raised				
On your back <i>with</i> the head of the bed raised to ___ degrees				
On your right side				
On your left side				
On your stomach				
Sitting up in bed				

6. Please describe which of the positions you alternate between during the time you spend in bed:

(D) SEATING:

1. How many hours do you sit in your wheelchair on an average day?

_____ hours (total time/day)

2. Do you stay in your wheelchair for this entire time without a break?

YES ____ NO ____

If NO, please describe how you break up your time in your wheelchair over a 24 hour period:

PMAT developed by Jennifer Birt, OT Reg (MB), Specialized Seating and Mobility Clinical Specialist
Rehabilitation Day Program Specialized Seating Service, Health Sciences Centre, Winnipeg, Manitoba

Client: _____ Date: _____

3. Do you reposition yourself or have others reposition you for the purpose of *pressure redistribution (i.e. shifting or relieving pressure away from specific parts of your body)* when sitting up in your wheelchair?

YES ____ NO ____

If YES:

How many times do you reposition each hour for the purpose of pressure redistribution? _____ times/hour

What type of movements do you perform for this repositioning? (Describe each movement):

How long is each repositioning movement held for? _____

If NO, meaning you do not reposition yourself for the purpose of pressure redistribution, why not?

(E) SKIN CHECKS:

1. Do you perform skin checks? YES ____ NO ____

If NO, why not?

* Please proceed to section (F) *BLADDER/BOWEL/MOISTURE CONTROL* if you answered NO to question 1 in section (E) *SKIN CHECKS* above.

If YES, by whom?

* Please complete the following questions (2 - 5) if you answered YES to question 1 in section (E) *SKIN CHECKS* above.

2. When are the skin checks typically performed?

How frequently do these checks occur?

PMAT developed by Jennifer Birt, OT Reg (MB), Specialized Seating and Mobility Clinical Specialist
Rehabilitation Day Program Specialized Seating Service, Health Sciences Centre, Winnipeg, Manitoba

Client: _____ Date: _____

3. What areas of your skin get checked? Please list all areas:

4. What do you look for when performing a skin check?

5. What do you do if you come across something that concerns you during a skin check?

(F) BLADDER/BOWEL/MOISTURE CONTROL:

1. Are you currently on a bladder routine? YES ____ NO ____
If YES, describe:

How long does it take to complete your bladder routine? _____
2. Do you ever have bladder incontinence? YES ____ NO ____
If YES, how is this incontinence managed?
3. Are you currently on a bowel routine? YES ____ NO ____
If YES, describe:

How long does it take to complete your bowel routine? _____
4. Do you ever have bowel incontinence? YES ____ NO ____
If YES, how is this incontinence managed?
5. Do you ever have issues with sweatiness? YES ____ NO ____
If YES, how is this sweat managed?

(G) CLOTHING:

1. What kinds of clothes (including footwear) do you typically wear?

PMAT developed by Jennifer Birt, OT Reg (MB), Specialized Seating and Mobility Clinical Specialist
Rehabilitation Day Program Specialized Seating Service, Health Sciences Centre, Winnipeg, Manitoba

Client: _____ Date: _____

(H) TRANSFERS & EQUIPMENT:

1. How many transfers do you typically perform in a day? _____ transfers
(NOTE: one transfer = movement in ONE direction)

2. Do you perform any of the following transfers?

Transfer	Yes	No	Transfer Method	Equipment Used	Padding on equipment surface?	
					Yes	No
BED						
WHEELCHAIR						
TOILET						
BATHTUB OR SHOWER						
CAR SEAT						
OTHER <i>Describe:</i>						

PMAT developed by Jennifer Birt, OT Reg (MB), Specialized Seating and Mobility Clinical Specialist
Rehabilitation Day Program Specialized Seating Service, Health Sciences Centre, Winnipeg, Manitoba

Client: _____ Date: _____

Part 2 - Assessment Findings

SUPPORT SURFACE EVALUATION:

Assess and complete the sections that are relevant to your client's situation based on answers provided in Part 1

Surface to be evaluated	Positions to be evaluated	Palpation and visual inspection of pressure ulcer(s) (Check applicable column)	
		Pressure ulcer is weightbearing	Pressure ulcer is offloaded
Bed	Supine (flat)		
	Supine with the head of the bed raised		
	Right side lying		
	Left side lying		
	Prone		
	Sitting up in bed		
Wheelchair	Resting posture		
	In tilt		
Toilet	Resting posture		
	Simulated pericare tasks		
Bathtub or Shower Seat	Resting posture		
	Simulated bathing tasks		
Car seat	Resting posture		
	Simulated driving tasks		
Other	Describe:		

PMAT developed by Jennifer Birt, OT Reg (MB), Specialized Seating and Mobility Clinical Specialist
Rehabilitation Day Program Specialized Seating Service, Health Sciences Centre, Winnipeg, Manitoba

Client: _____ Date: _____

EQUIPMENT CHECK:

Assess and complete the sections that are relevant to your client's situation based on answers provided in part 1

Equipment	Set-up properly?		In good condition?	
	Yes	No	Yes	No
Bed				
Mattress				
Wheelchair				
Cushion				
Backrest				
Toilet or commode				
Bathtub or shower seat				
Car seat				
Other				

SKIN CHECK:

1. Observe client performing (or providing direction to complete) a skin check.

Answer the following:

Client is capable of performing (or directing) the skin check YES ____ NO ____
 Client knows what they should be looking for YES ____ NO ____
 Client knows what they should be feeling for YES ____ NO ____
 Client can accurately indicate areas of concern YES ____ NO ____

2. Complete a visual skin inspection and record relevant information below:

Location	Stage	Size	Description
Right ischial tuberosity			
Left ischial tuberosity			
Right greater trochanter			
Left greater trochanter			
Coccyx			

PMAT developed by Jennifer Birt, OT Reg (MB), Specialized Seating and Mobility Clinical Specialist
 Rehabilitation Day Program Specialized Seating Service, Health Sciences Centre, Winnipeg, Manitoba

Client: _____ Date: _____

Location	Stage	Size	Description
Sacrum			
Right heel			
Left heel			
Other areas of lower limbs			
Right elbow			
Left elbow			
Right scapula			
Left scapula			
Other			

TRANSFER and MOBILITY ASSESSMENT:

Observe and comment on client and/or caregivers performing relevant movements

Movement	Effective?		Shear, friction, or trauma?		Describe any issues or concerns
	YES	NO	YES	NO	
Full body lift transfer performed by caregivers					
Mechanical lift transfer					
Sliding board transfer					
Side transfer with partial lift using upper extremities only					
Side transfer with full lift using upper extremities only					

PMAT developed by Jennifer Birt, OT Reg (MB), Specialized Seating and Mobility Clinical Specialist
Rehabilitation Day Program Specialized Seating Service, Health Sciences Centre, Winnipeg, Manitoba

Client: _____ Date: _____

Movement	Effective?		Shear, friction, or trauma?		Describe any issues or concerns
	Yes	No	Yes	No	
Scoot pivot transfer					
Standing pivot transfer					
Manual wheelchair propulsion					
Power wheelchair driving					
Power wheelchair dynamic seat functions (tilt, recline, power elevating legrests)					
Turning in bed					
Transitioning between sitting and lying in bed					
Shifting up, down, and to each side in bed					

PRESSURE REDISTRIBUTION MOVEMENTS IN SITTING:

Movement Demonstrated	Capable of movement?		Movement is effective? Palpate to confirm pressure ulcer offloaded with movement	
	YES	NO	YES	NO
Forward lean				
Upper body push-up				
Right side lean				
Left side lean				
Manual tilt-in-space How far is client tilted?				

PMAT developed by Jennifer Birt, OT Reg (MB), Specialized Seating and Mobility Clinical Specialist
Rehabilitation Day Program Specialized Seating Service, Health Sciences Centre, Winnipeg, Manitoba

Client: _____ Date: _____

Movement Demonstrated	Capable of movement?		Movement is effective? Palpate to confirm pressure ulcer offloaded with movement	
	YES	NO	YES	NO
Power tilt-in-space How far does client tilt? _____°				
Other (describe):				

SCREEN OF POSTURE IN SITTING:

Postural Tendencies	
Pelvis and hips	
Lower extremities	
Trunk	
Upper extremities	
Head and neck	

COGNITIVE SCREEN:

Based on results from part 1 and 2 of the PMAT, list any concerns related to pressure management in the following areas:

Insight, awareness, and comprehension	
Problem solving	
Memory	
Behaviour and lifestyle choices	
Other	

PMAT developed by Jennifer Birt, OT Reg (MB), Specialized Seating and Mobility Clinical Specialist
Rehabilitation Day Program Specialized Seating Service, Health Sciences Centre, Winnipeg, Manitoba

Pressure Management Assessment Tool

Page 14

Client: _____ Date: _____

Part 3 - Findings:

ASSESSMENT SUMMARY:

RECOMMENDATIONS:

Report completed by:

PMAT developed by Jennifer Birt, OT Reg (MB), Specialized Seating and Mobility Clinical Specialist
Rehabilitation Day Program Specialized Seating Service, Health Sciences Centre, Winnipeg, Manitoba

C. WINNIPEG HEALTH SCIENCES CENTRE

Adapted with permission from Winnipeg Health Sciences Centre



Health Sciences Centre
Winnipeg

Specialized Seating Services
Rehabilitation Day Program

CLIENT INTERVIEW

Date:	Client's name:	People present:
--------------	-----------------------	------------------------

Seating Issues Identified from Referral:

1	
2	
3	
4	
5	

Seating Issues Identified by Client, Caregivers, and/or Healthcare Providers During Assessment:

1	
2	
3	
4	
5	
6	
7	
8	
9	
10	

Are there specific things you like about your current wheelchair and seating equipment? (i.e. what is important for you to keep?)

Are there specific things you dislike about your current wheelchair and seating equipment? (i.e. what would you like to see changed?)

820 Sherbrook Street (RR160E), Winnipeg, Manitoba R3A 1R9 / Phone 204-787-4266 / Fax 204-787-8637 jlbirt@hsc.mb.ca

An operating
division of the



Winnipeg Regional
Health Authority
Office régional de la
santé de Winnipeg

Affiliated
with the



UNIVERSITY
OF MANITOBA



Health Sciences Centre
Winnipeg

Specialized Seating Services
Rehabilitation Day Program

OCCUPATIONAL PERFORMANCE: Please describe a typical day with respect to the following categories:

<p>Self-care Consider: level of independence, amount of assistance or support, surfaces utilized to carry out tasks, when and how tasks are completed, utilization of wheelchair for these tasks</p>	
<p>Transfers Consider: method, what surfaces are being transferred on and off of, types of equipment utilized, amount of transfers/day, wheelchair sitting height</p>	
<p>Mobility Consider: how a person pushes or drives their wheelchair, how functional are these methods, level of independence in different environments, is there a risk of shoulder injury</p>	
<p>Sitting Tolerance Consider: total number of hours in wheelchair/day, does it fluctuate, is it limited and why, are there breaks between sitting times, how many hours does a person want to sit for</p>	
<p>Pressure Management and Repositioning Consider: what movements does a person perform for the purposes of repositioning and pressure management, how often are these positions performed, how effective are they, do these movements get performed independently or is assistance required</p>	
<p>Home Management Tasks Consider: what are the person's responsibilities at home and how does their wheelchair seating system impact the ability to do these tasks</p>	
<p>Home Environment Consider: physical layout of the home and identify any accessibility concerns; will there be issues if the size or shape of their wheelchair system changes with intervention? Also consider equipment utilized</p>	

820 Sherbrook Street (RR160E), Winnipeg, Manitoba R3A 1R9 / Phone 204-787-4266 / Fax 204-787-8637 jlbird@hsc.mb.ca

An operating
division of the



Winnipeg Regional
Health Authority
Office régional de la
santé de Winnipeg

Affiliated
with the



UNIVERSITY
OF MANITOBA



Health Sciences Centre
Winnipeg

Specialized Seating Services
Rehabilitation Day Program

<p>Community Management Tasks Consider: what are the tasks that a person needs to access the community for? Are there accessibility issues?</p>	
<p>Productivity and Leisure Consider: tasks performed for paid or unpaid work, number of hours a person spends working, volunteering, or engaging in leisure tasks</p>	
<p>Transportation Consider: how does a person get around, how does their wheelchair equipment get loaded into the vehicle, equipment set up, driver vs passenger, will there be issues with utilizing transportation method if wheelchair equipment changes</p>	
<p>Community Environment(s) Consider: any additional accessibility concerns among the environments outside the home</p>	
<p>Equipment Consider: all surfaces client utilizes throughout the day for pressure management, modifications for environmental access, additional wheelchair and seating equipment</p>	

COGNITIVE AND PERCEPTUAL PERFORMANCE COMPONENTS: Please indicate whether there are issues with any of the following:

Cognition:

Perception:

Affect:

820 Sherbrook Street (RR160E), Winnipeg, Manitoba R3A 1R9 / Phone 204-787-4266 / Fax 204-787-8637 jlbert@hsc.mb.ca

An operating
division of the



Winnipeg Regional
Health Authority
Office régional de la
santé de Winnipeg

Affiliated
with the



UNIVERSITY
OF MANITOBA



Health Sciences Centre
Winnipeg

Specialized Seating Services
Rehabilitation Day Program

PHYSICAL PERFORMANCE COMPONENTS:

Diagnosis:

Medications:

Height:

Weight:

- 1.
- 2.
- 3.
- 4.

Relevant Medical History and Surgeries:

-
-
-
-

Please indicate whether there are issues with any of the following:

(Note this information is all client report)

Skin Condition	<input type="checkbox"/> normal <input type="checkbox"/> healed sores <input type="checkbox"/> open sores	Location(s) of sores: Possible cause(s):
Tone	<input type="checkbox"/> normal <input type="checkbox"/> hypertonic <input type="checkbox"/> hypotonic	Location of tone: Triggers: Inhibitors: Tonal effect on posture:
Pain	<input type="checkbox"/> normal <input type="checkbox"/> pain present Location(s) of pain: Triggers: Relieved by:	Pain scale rating: at best: ___ / 10 at worst: ___ / 10 ideal: ___ / 10 (goal)
Sensation	<input type="checkbox"/> normal <input type="checkbox"/> impaired <ul style="list-style-type: none"> <input type="checkbox"/> fully impaired <input type="checkbox"/> partially impaired 	Location of impaired sensation: Description of impaired sensation:

820 Sherbrook Street (RR160E), Winnipeg, Manitoba R3A 1R9 / Phone 204-787-4266 / Fax 204-787-8637 jlbirt@hsc.mb.ca

An operating
division of the



Winnipeg Regional
Health Authority
Office régional de la
santé de Winnipeg

Affiliated
with the



UNIVERSITY
OF MANITOBA



Specialized Seating Services
Rehabilitation Day Program

POSTURE IN CURRENT SEATING SYSTEM (BASELINE POSTURE)

TILT			OBLIQUITY			ROTATION		
Neutral	Posterior	Anterior	Neutral	Client's right side high	Client's left side high	Neutral	Client's right side forward	Client's left side forward
<input type="checkbox"/>	<input type="checkbox"/>	<input type="checkbox"/>	<input type="checkbox"/>	<input type="checkbox"/>	<input type="checkbox"/>	<input type="checkbox"/>	<input type="checkbox"/>	<input type="checkbox"/>

FLEXION/EXTENSION						ABD/ADDUCTION						ROTATION						WINDSWEPT					
Neutral (90°)		Flexed (<90°)		Extended (>90°)		Neutral		Abduction		Adduction		Neutral ER		IR		Neutral		Right		Left			
R	L	R	L	R	L	R	L	R	L	R	L	R	L	R	L	R	L	R	L	R	L		
<input type="checkbox"/>	<input type="checkbox"/>	<input type="checkbox"/>	<input type="checkbox"/>	<input type="checkbox"/>	<input type="checkbox"/>	<input type="checkbox"/>	<input type="checkbox"/>	<input type="checkbox"/>	<input type="checkbox"/>	<input type="checkbox"/>	<input type="checkbox"/>	<input type="checkbox"/>	<input type="checkbox"/>	<input type="checkbox"/>	<input type="checkbox"/>	<input type="checkbox"/>	<input type="checkbox"/>	<input type="checkbox"/>	<input type="checkbox"/>	<input type="checkbox"/>	<input type="checkbox"/>		

KNEES					
FLEXION/EXTENSION					
Neutral (90°)		Flexion (<90°)		Extension (>90°)	
R	L	R	L	R	L
<input type="checkbox"/>	<input type="checkbox"/>	<input type="checkbox"/>	<input type="checkbox"/>	<input type="checkbox"/>	<input type="checkbox"/>

FEET/ANKLE											
Dorsiflexion		Plantar flexion		Inversion		Eversion		Toe in		Toe out	
R	L	R	L	R	L	R	L	R	L	R	L
<input type="checkbox"/>	<input type="checkbox"/>	<input type="checkbox"/>	<input type="checkbox"/>	<input type="checkbox"/>	<input type="checkbox"/>	<input type="checkbox"/>	<input type="checkbox"/>	<input type="checkbox"/>	<input type="checkbox"/>	<input type="checkbox"/>	<input type="checkbox"/>

820 Sherbrook Street (RR160E), Winnipeg, Manitoba R3A 1R9 / Phone 204-787-4266 / Fax 204-787-8637 jlbirt@hsc.mb.ca





Specialized Seating Services
Rehabilitation Day Program

TRUNK

LEANING			ROTATION			KYPHOSIS			LORDOSIS	
Neutral i.e. Midline	Right Side	Left Side	Neutral	Right side forward	Left side forward	Neutral (mild curve in thorax)	Present <input type="checkbox"/>		Neutral (mild curve in L-spine)	Present
<input type="checkbox"/>	<input type="checkbox"/>	<input type="checkbox"/>	<input type="checkbox"/>	<input type="checkbox"/>	<input type="checkbox"/>	<input type="checkbox"/>	Thoracic	Lumbar	<input type="checkbox"/>	<input type="checkbox"/>

SHOULDERS

NEUTRAL	PROTRACTION		RETRACTION		ELEVATION		DEPRESSION	
<input type="checkbox"/>	R	L	R	L	R	L	R	L
<input type="checkbox"/>	<input type="checkbox"/>	<input type="checkbox"/>	<input type="checkbox"/>	<input type="checkbox"/>	<input type="checkbox"/>	<input type="checkbox"/>	<input type="checkbox"/>	<input type="checkbox"/>

HEAD AND NECK

NEUTRAL	FLEXION (kyphotic)	EXTENSION (lordotic)	LATERAL FLEXION		ROTATION		CHIN POKE
<input type="checkbox"/>	<input type="checkbox"/>	<input type="checkbox"/>	R	L	R	L	<input type="checkbox"/>
<input type="checkbox"/>	<input type="checkbox"/>	<input type="checkbox"/>	<input type="checkbox"/>	<input type="checkbox"/>	<input type="checkbox"/>	<input type="checkbox"/>	<input type="checkbox"/>

UPPER EXTREMITY

Describe posture:	
--------------------------	--

Digital photo taken? Yes No



820 Sherbrook Street (RR160E), Winnipeg, Manitoba R3A 1R9 / Phone 204-787-4266 / Fax 204-787-8637 jlbirt@hsc.mb.ca





Health Sciences Centre
Winnipeg

Specialized Seating Services
Rehabilitation Day Program

SUPINE EVALUATION

SUPINE POSTURES

<p>Tone High <input type="checkbox"/> Low <input type="checkbox"/></p> <p>Location:</p> <p>Influence on supine posture:</p> <p>Can tone be reduced? Y <input type="checkbox"/> N <input type="checkbox"/> If yes, how?</p> <p>List specific postures that help inhibit tone:</p>	<p>Joint Contractures? Y <input type="checkbox"/> N <input type="checkbox"/></p> <p>Location:</p> <p>Influence on supine posture:</p>	<p>Soft tissue compression? Y <input type="checkbox"/> N <input type="checkbox"/></p> <p>Location:</p> <p>Influence on supine posture?</p>
	<p>Pain? Y <input type="checkbox"/> N <input type="checkbox"/></p> <p>Location:</p> <p>Influence on supine posture?</p>	<p>Breathing or swallowing compromised? Y <input type="checkbox"/> N <input type="checkbox"/></p> <p>Describe issues:</p>

SKIN CHECK

<p>Visual inspection of client's skin over seated surfaces including:</p> <ul style="list-style-type: none"> • Ischial tuberosities (IT's) • Coccyx/sacrum • Greater trochanters (GT's) • Spine and shoulder blades • Knees and ankles 	<p>Describe skin condition and dressings (if applicable):</p>
-------------------------------------------------------------------------------------------------------------------------------------------------------------------------------------------------------------------------------------------------------------------------------------------	---------------------------------------------------------------



Digital photo(s) of skin check taken? Y N

820 Sherbrook Street (RR160E), Winnipeg, Manitoba R3A 1R9 / Phone 204-787-4266 / Fax 204-787-8637 jlbird@hsc.mb.ca

An operating
division of the



Winnipeg Regional
Health Authority
Office régional de la
santé de Winnipeg

Affiliated
with the



UNIVERSITY
OF MANITOBA



Health Sciences Centre
Winnipeg

Specialized Seating Services
Rehabilitation Day Program

PELVIS EVALUATION IN SUPINE

PELVIC TILT		
Neutral <input type="checkbox"/> (Tolerates ROM through anterior and posterior tilt)	Posterior <input type="checkbox"/> 	Anterior <input type="checkbox"/>
	Flexible out of destructive posture? Y <input type="checkbox"/> N <input type="checkbox"/>	Flexible out of destructive posture? Y <input type="checkbox"/> N <input type="checkbox"/>
	If yes: Full correction <input type="checkbox"/> Limited correction <input type="checkbox"/>	If yes: Full correction <input type="checkbox"/> Limited correction <input type="checkbox"/>
	Correction primarily limited by:	Correction primarily limited by:
OBLIQUITY		
Neutral <input type="checkbox"/> (Tolerates ROM through right and left obliquity)	Client's left side high <input type="checkbox"/> 	Client's right side high <input type="checkbox"/>
	Flexible out of destructive posture? Y <input type="checkbox"/> N <input type="checkbox"/>	Flexible out of destructive posture? Y <input type="checkbox"/> N <input type="checkbox"/>
	If yes: Full correction <input type="checkbox"/> Limited correction <input type="checkbox"/>	If yes: Full correction <input type="checkbox"/> Limited correction <input type="checkbox"/>
	Correction primarily limited by:	Correction primarily limited by:
ROTATION		
Neutral <input type="checkbox"/> (Tolerates ROM through right and left rotation)	Client's right side forward <input type="checkbox"/> 	Client's left side forward <input type="checkbox"/>
	Flexible out of destructive posture? Y <input type="checkbox"/> N <input type="checkbox"/>	Flexible out of destructive posture? Y <input type="checkbox"/> N <input type="checkbox"/>
	If yes: Full correction <input type="checkbox"/> Limited correction <input type="checkbox"/>	If yes: Full correction <input type="checkbox"/> Limited correction <input type="checkbox"/>
	Correction primarily limited by:	Correction primarily limited by:

HIP EVALUATION IN SUPINE

HIP ABDUCTION/ADDUCTION (NOTE: test flexibility with hips and knees flexed)		
Neutral R <input type="checkbox"/> L <input type="checkbox"/> (Tolerates ROM through abduction and adduction)	Abduction R <input type="checkbox"/> L <input type="checkbox"/> 	Adduction R <input type="checkbox"/> L <input type="checkbox"/>
	Flexible out of destructive posture? Y <input type="checkbox"/> N <input type="checkbox"/>	Flexible out of destructive posture? Y <input type="checkbox"/> N <input type="checkbox"/>
	If yes: Full correction <input type="checkbox"/> Limited correction <input type="checkbox"/>	If yes: Full correction <input type="checkbox"/> Limited correction <input type="checkbox"/>
	Correction primarily limited by:	Correction primarily limited by:

820 Sherbrook Street (RR160E), Winnipeg, Manitoba R3A 1R9 / Phone 204-787-4266 / Fax 204-787-8637 jlbirt@hsc.mb.ca

An operating
division of the



Winnipeg Regional
Health Authority
Office régional de la
santé de Winnipeg

Affiliated
with the



UNIVERSITY
OF MANITOBA



Health Sciences Centre
Winnipeg

Specialized Seating Services
Rehabilitation Day Program

HIP INTERNAL/EXTERNAL ROTATION (NOTE: test flexibility with hips and knees flexed)		
Neutral R <input type="checkbox"/> L <input type="checkbox"/> [Tolerates ROM through internal and external rotation]	Internal Rotation R <input type="checkbox"/> L <input type="checkbox"/> 	External Rotation R <input type="checkbox"/> L <input type="checkbox"/>
	Flexible out of destructive posture? Y <input type="checkbox"/> N <input type="checkbox"/>	Flexible out of destructive posture? Y <input type="checkbox"/> N <input type="checkbox"/>
	If yes: Full correction <input type="checkbox"/> Limited correction <input type="checkbox"/>	If yes: Full correction <input type="checkbox"/> Limited correction <input type="checkbox"/>
	Correction primarily limited by:	Correction primarily limited by:

FLEXION/EXTENSION ANGLES OF LOWER BODY

JOINT	ROM		NOTES	
	R	L		
Hips, Knees, and Ankles NOTE: measurements should occur in this order: 1. measure hip flexion/extension while allowing knees and ankles to relax 2. keep hips in desired flexion angle to then measure knee flexion/extension 3. keep hips and knees in desired angle then measure ankle dorsi and plantar flexion 	Hip Flexion (trunk to thigh angle)	_____ *	_____ *	ROM primarily limited by:
	Hip Extension (trunk to thigh angle)	_____ *	_____ *	ROM primarily limited by:
	Knee Flexion (posterior thigh to lower leg angle)	_____ *	_____ *	ROM primarily limited by:
	Knee Extension (posterior thigh to lower leg angle)	_____ *	_____ *	ROM primarily limited by:
	Ankle Dorsiflexion (angle between top of foot & lower leg)	_____ *	_____ *	ROM primarily limited by:
	Ankle Plantarflexion (angle between top of foot & lower leg)	_____ *	_____ *	ROM primarily limited by:

820 Sherbrook Street (RR160E), Winnipeg, Manitoba R3A 1R9 / Phone 204-787-4266 / Fax 204-787-8637 jlbirt@hsc.mb.ca

An operating
division of the













Winnipeg Regional
Health Authority
Office régional de la
santé de Winnipeg

Affiliated
with the







UNIVERSITY
OF MANITOBA

UPPER BODY EVALUATION IN SUPINE







TRUNK						
<p>Neutral <input type="checkbox"/></p>  <p>Relaxed posture has a mild lordosis in lumbar spine and mild kyphosis in thoracic spine and mild lordosis in cervical spine</p>	<p>Rib elongation R <input type="checkbox"/> L <input type="checkbox"/></p> 	<p>Kyphosis Thoracic <input type="checkbox"/> Lumbar <input type="checkbox"/></p> 	<p>Lordosis <input type="checkbox"/></p> 	<p>Rotation</p> <table border="1"> <tr> <td> <p>Right forward <input type="checkbox"/></p>  </td> <td> <p>Left forward <input type="checkbox"/></p>  </td> </tr> </table>	<p>Right forward <input type="checkbox"/></p> 	<p>Left forward <input type="checkbox"/></p> 
	<p>Right forward <input type="checkbox"/></p> 	<p>Left forward <input type="checkbox"/></p> 				
	<p>Flexible out of destructive posture? Y <input type="checkbox"/> N <input type="checkbox"/></p>	<p>Flexible out of destructive posture? Y <input type="checkbox"/> N <input type="checkbox"/></p>	<p>Flexible out of destructive posture? Y <input type="checkbox"/> N <input type="checkbox"/></p>	<p>Flexible out of destructive posture? Y <input type="checkbox"/> N <input type="checkbox"/></p>	<p>Flexible out of destructive posture? Y <input type="checkbox"/> N <input type="checkbox"/></p>	
	<p>If yes: Full correction <input type="checkbox"/> Limited correction <input type="checkbox"/></p>	<p>If yes: Full correction <input type="checkbox"/> Limited correction <input type="checkbox"/></p>	<p>If yes: Full correction <input type="checkbox"/> Limited correction <input type="checkbox"/></p>	<p>If yes: Full correction <input type="checkbox"/> Limited correction <input type="checkbox"/></p>	<p>If yes: Full correction <input type="checkbox"/> Limited correction <input type="checkbox"/></p>	
<p>Correction primarily limited by:</p>	<p>Correction primarily limited by:</p>	<p>Correction primarily limited by:</p>	<p>Correction primarily limited by:</p>	<p>Correction primarily limited by:</p>		

SHOULDERS

<p>Neutral R <input type="checkbox"/> L <input type="checkbox"/></p> <p>Tolerates full ROM of shoulders</p>	<p>Protracted R <input type="checkbox"/> L <input type="checkbox"/></p> 	<p>Retracted R <input type="checkbox"/> L <input type="checkbox"/></p> 	<p>Elevated R <input type="checkbox"/> L <input type="checkbox"/></p> 	<p>Depressed R <input type="checkbox"/> L <input type="checkbox"/></p> 	
	<p>Flexible out of destructive posture? Y <input type="checkbox"/> N <input type="checkbox"/></p>	<p>Flexible out of destructive posture? Y <input type="checkbox"/> N <input type="checkbox"/></p>	<p>Flexible out of destructive posture? Y <input type="checkbox"/> N <input type="checkbox"/></p>	<p>Flexible out of destructive posture? Y <input type="checkbox"/> N <input type="checkbox"/></p>	<p>Flexible out of destructive posture? Y <input type="checkbox"/> N <input type="checkbox"/></p>
	<p>If yes: Full correction <input type="checkbox"/> Limited correction <input type="checkbox"/></p>	<p>If YES: Full correction <input type="checkbox"/> Limited correction <input type="checkbox"/></p>	<p>If YES: Full correction <input type="checkbox"/> Limited correction <input type="checkbox"/></p>	<p>If YES: Full correction <input type="checkbox"/> Limited correction <input type="checkbox"/></p>	<p>If YES: Full correction <input type="checkbox"/> Limited correction <input type="checkbox"/></p>
	<p>ROM primarily limited by:</p>	<p>ROM primarily limited by:</p>	<p>ROM primarily limited by:</p>	<p>ROM primarily limited by:</p>	<p>ROM primarily limited by:</p>

820 Sherbrook Street (RR160E), Winnipeg, Manitoba R3A 1R9 / Phone 204-787-4266 / Fax 204-787-8637 jlbirt@hsc.mb.ca

HEAD AND NECK

<p>Neutral <input type="checkbox"/></p> <p>Tolerates full ROM of head and neck</p>  <p><i>Restorou neuromy Posture</i></p>	<p>Flexed <input type="checkbox"/></p> 	<p>Extended <input type="checkbox"/></p> 	<p>Laterally Flexed <input type="checkbox"/></p> <p>R <input type="checkbox"/> L <input type="checkbox"/></p> 	<p>Rotated <input type="checkbox"/></p> <p>R <input type="checkbox"/> L <input type="checkbox"/></p> 	<p>Chin poke <input type="checkbox"/></p>  <p><i>Anterior Translation</i></p>
	<p>Flexible out of destructive posture? Y <input type="checkbox"/> N <input type="checkbox"/></p>	<p>Flexible out of destructive posture? Y <input type="checkbox"/> N <input type="checkbox"/></p>	<p>Flexible out of destructive posture? Y <input type="checkbox"/> N <input type="checkbox"/></p>	<p>Flexible out of destructive posture? Y <input type="checkbox"/> N <input type="checkbox"/></p>	<p>Flexible out of destructive posture? Y <input type="checkbox"/> N <input type="checkbox"/></p>
	<p>If yes: Full correction <input type="checkbox"/> Limited correction <input type="checkbox"/></p>	<p>If yes: Full correction <input type="checkbox"/> Limited correction <input type="checkbox"/></p>	<p>If yes: Full correction <input type="checkbox"/> Limited correction <input type="checkbox"/></p>	<p>If yes: Full correction <input type="checkbox"/> Limited correction <input type="checkbox"/></p>	<p>If yes: Full correction <input type="checkbox"/> Limited correction <input type="checkbox"/></p>
<p>ROM primarily limited by:</p>	<p>ROM primarily limited by:</p>	<p>ROM primarily limited by:</p>	<p>ROM primarily limited by:</p>	<p>ROM primarily limited by:</p>	<p>ROM primarily limited by:</p>



Digital photo(s) of supine postures taken? Y N

820 Sherbrook Street (RR160E), Winnipeg, Manitoba R3A 1R9 / Phone 204-787-4266 / Fax 204-787-8637 jlbirt@hsc.mb.ca

An operating division of the



Winnipeg Regional Health Authority
Office regional de la santé de Winnipeg

Affiliated with the



UNIVERSITY OF MANITOBA



Health Sciences Centre
Winnipeg

Specialized Seating Services
Rehabilitation Day Program

SITTING EVALUATION (on a solid surface)

SITTING BALANCE					
Hands free with dynamic movement <input type="checkbox"/>	Hands free but no dynamic movement <input type="checkbox"/>	Hands required to balance <input type="checkbox"/>	Requires assistance <input type="checkbox"/>		
			Min <input type="checkbox"/>	Mod <input type="checkbox"/>	Max <input type="checkbox"/>

POSTURAL TENDENCIES IN SITTING PRIOR TO CORRECTION

PELVIS													
Neutral <input type="checkbox"/>	Tilt				Obliquity				Rotation				
	Anterior <input type="checkbox"/>		Posterior <input type="checkbox"/>		R high <input type="checkbox"/>		L high <input type="checkbox"/>		R forward <input type="checkbox"/>		L forward <input type="checkbox"/>		
HIPS													
Neutral <input type="checkbox"/>	Flexed		Extended		Abducted		Adducted		Internally Rotated		Externally Rotated		
	R <input type="checkbox"/>	L <input type="checkbox"/>	R <input type="checkbox"/>	L <input type="checkbox"/>	R <input type="checkbox"/>	L <input type="checkbox"/>	R <input type="checkbox"/>	L <input type="checkbox"/>	R <input type="checkbox"/>	L <input type="checkbox"/>	R <input type="checkbox"/>	L <input type="checkbox"/>	
KNEES													
Neutral <input type="checkbox"/>		Flexed <input type="checkbox"/>				Extended <input type="checkbox"/>							
R <input type="checkbox"/>		L <input type="checkbox"/>		R <input type="checkbox"/>				L <input type="checkbox"/>		R <input type="checkbox"/>		L <input type="checkbox"/>	
FEET AND ANKLE													
Neutral <input type="checkbox"/>	Dorsiflexed		Plantar flexed		Inverted		Everted						
	R <input type="checkbox"/>	L <input type="checkbox"/>	R <input type="checkbox"/>	L <input type="checkbox"/>	R <input type="checkbox"/>	L <input type="checkbox"/>	R <input type="checkbox"/>	L <input type="checkbox"/>	R <input type="checkbox"/>	L <input type="checkbox"/>			
TRUNK													
Neutral <input type="checkbox"/>	Lordosis <input type="checkbox"/>		Kyphosis				Leaning						
			Thoracic <input type="checkbox"/>		Lumbar <input type="checkbox"/>		R <input type="checkbox"/>		L <input type="checkbox"/>				
SHOULDERS													
Neutral <input type="checkbox"/>	Protracted		Retracted		Elevated		Depressed						
	R <input type="checkbox"/>	L <input type="checkbox"/>	R <input type="checkbox"/>	L <input type="checkbox"/>	R <input type="checkbox"/>	L <input type="checkbox"/>	R <input type="checkbox"/>	L <input type="checkbox"/>	R <input type="checkbox"/>	L <input type="checkbox"/>			
HEAD AND NECK													
Neutral <input type="checkbox"/>	Flexed <input type="checkbox"/>		Extended <input type="checkbox"/>		Rotated		Laterally Flexed		Chin poke <input type="checkbox"/>				
					R <input type="checkbox"/>	L <input type="checkbox"/>	R <input type="checkbox"/>	L <input type="checkbox"/>					



Digital photos taken of unsupported sitting posture? Y N

820 Sherbrook Street (RR160E), Winnipeg, Manitoba R3A 1R9 / Phone 204-787-4266 / Fax 204-787-8637 jlbirt@hsc.mb.ca

An operating
division of the











Winnipeg Regional
Health Authority
Office régional de la
santé de Winnipeg



Affiliated
with the



UNIVERSITY
OF MANITOBA

SCOLIOSIS EVALUATION SITTING ON A SOLID SURFACE

Visual inspection of client's spine							
Please indicate the presence of the following:							
Rib hump: <input type="checkbox"/> 	Head not centered over the rest of the body <input type="checkbox"/> 	Uneven shoulder and/or scapula height <input type="checkbox"/> 	One scapula more prominent than the other <input type="checkbox"/> 	Uneven hip/pelvis height <input type="checkbox"/> 	One side of pelvis more prominent than the other <input type="checkbox"/> 	Skin fold on shorter side of rib cage <input type="checkbox"/> 	Unequal gaps between arms and trunk <input type="checkbox"/> 

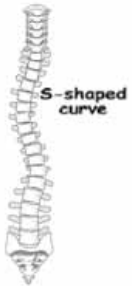
Type of lateral curvature(s) in spine							
Neutral <input type="checkbox"/> 	C-curve present <input type="checkbox"/> Level of spine Cervical <input type="checkbox"/> Thoracic <input type="checkbox"/> Lumbar <input type="checkbox"/> Apex to the Right <input type="checkbox"/> Apex to the Left <input type="checkbox"/> 			S-curve present <input type="checkbox"/> 		Apex to the RIGHT at: Cervical <input type="checkbox"/> Thoracic <input type="checkbox"/> Lumbar <input type="checkbox"/>	Apex to the LEFT at: Cervical <input type="checkbox"/> Thoracic <input type="checkbox"/> Lumbar <input type="checkbox"/>
Flexibility of Scoliosis Flexible out of destructive posture? Y <input type="checkbox"/> N <input type="checkbox"/> If yes:							
Full correction <input type="checkbox"/>	Limited correction <input type="checkbox"/>	Correction primarily limited by:					

820 Sherbrook Street (RR160E), Winnipeg, Manitoba R3A 1R9 / Phone 204-787-4266 / Fax 204-787-8637 jlbirt@hsc.mb.ca

An operating division of the



Winnipeg Regional Health Authority
 Centre de santé de Winnipeg

Affiliated with the



UNIVERSITY OF MANITOBA





Digital photo taken? Y N

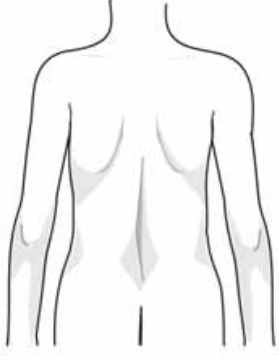

Health Sciences Centre
Winnipeg

Specialized Seating Services
Rehabilitation Day Program

Draw curvatures of spine here	
Scoliotic curves	Kyphotic and lordotic curves
	

820 Sherbrook Street (RR160E), Winnipeg, Manitoba R3A 1R9 / Phone 204-787-4266 / Fax 204-787-8637 jlbert@hsc.mb.ca

An operating
division of the



Winnipeg Regional
Health Authority
Office régional de la
santé de Winnipeg

Affiliated
with the



UNIVERSITY
OF MANITOBA



Health Sciences Centre
Winnipeg

Specialized Seating Services
Rehabilitation Day Program

POSTURAL EVALUATION AND SEATING SIMULATION IN SITTING

	Describe ideal postures that can be achieved with maximum tolerated correction			Describe parameters of positioning components that will be needed in seating system to achieve targeted postures	Tolerance for full correction of postures primarily limited by:	
PELVIS	Tilt	Neutral	<input type="checkbox"/>			
		Posterior	<input type="checkbox"/>			
		Anterior	<input type="checkbox"/>			
	Obliquity	Neutral	<input type="checkbox"/>			
		Right high	<input type="checkbox"/>			
		Left high	<input type="checkbox"/>			
	Rotation	Neutral	<input type="checkbox"/>			
		Right forward	<input type="checkbox"/>			
		Left forward	<input type="checkbox"/>			
HIPS	Flexion angle	Right	Left			
		_____ °	_____ °			
	External Rotation	Neutral	<input type="checkbox"/>			
		Right	<input type="checkbox"/>			
		Left	<input type="checkbox"/>			
	Internal Rotation	Neutral	<input type="checkbox"/>			
		Right	<input type="checkbox"/>			
		Left	<input type="checkbox"/>			
	Abduction	Neutral	<input type="checkbox"/>			
		Right	<input type="checkbox"/>			
		Left	<input type="checkbox"/>			
	Adduction	Neutral	<input type="checkbox"/>			
Right		<input type="checkbox"/>				
Left		<input type="checkbox"/>				
KNEES	Flexion angle	Right	Left			
		_____ °	_____ °			
ANKLES AND FEET	Neutral	<input type="checkbox"/>				
	Dorsiflexion	<input type="checkbox"/>				
		Neutral			<input type="checkbox"/>	
		Right			<input type="checkbox"/>	
	Inversion	<input type="checkbox"/>			Left	<input type="checkbox"/>
		Eversion			Neutral	<input type="checkbox"/>
					Right	<input type="checkbox"/>
Left			<input type="checkbox"/>			

820 Sherbrook Street (RR160E), Winnipeg, Manitoba R3A 1R9 / Phone 204-787-4266 / Fax 204-787-8637 jlbirt@hsc.mb.ca

An operating
division of the



Winnipeg Regional
Health Authority
Office régional de la
santé de Winnipeg

Affiliated
with the



UNIVERSITY
OF MANITOBA

	Describe ideal postures that can be achieved with maximum tolerated correction		Describe parameters of positioning components that will be needed in seating system to achieve targeted postures	Tolerance for full correction of postures primarily limited by:
TRUNK	Neutral	<input type="checkbox"/>		
	Kyphosis <input type="checkbox"/>	Lumbar	<input type="checkbox"/>	
		Thoracic	<input type="checkbox"/>	
	Lordosis	<input type="checkbox"/>		
	Scoliosis <input type="checkbox"/>	Neutral	<input type="checkbox"/>	
		C-curve <input type="checkbox"/>	Apex to right <input type="checkbox"/>	
	S-curve <input type="checkbox"/>	right apex at	left apex at	
SHOULDERS	Neutral	<input type="checkbox"/>		
	Protraction	Right	<input type="checkbox"/>	
		Left	<input type="checkbox"/>	
	Retraction	Right	<input type="checkbox"/>	
		Left	<input type="checkbox"/>	
	Elevation	Right	<input type="checkbox"/>	
		Left	<input type="checkbox"/>	
Depression	Right	<input type="checkbox"/>		
	Left	<input type="checkbox"/>		
HEAD AND NECK	Neutral	<input type="checkbox"/>		
	Flexed	<input type="checkbox"/>		
	Extended	<input type="checkbox"/>		
	Laterally flexed	Right	<input type="checkbox"/>	
		Left	<input type="checkbox"/>	
	Rotated	Right	<input type="checkbox"/>	
		Left	<input type="checkbox"/>	
Chin poke	<input type="checkbox"/>			

 Digital photos taken of corrected posture? Y N

820 Sherbrook Street (RR160E), Winnipeg, Manitoba R3A 1R9 / Phone 204-787-4266 / Fax 204-787-8637 jlbirt@hsc.mb.ca

 An operating
division of the

 Winnipeg Regional
Health Authority
Ottawa régional de la
santé de Winnipeg

 Affiliated
with the

 UNIVERSITY
OF MANITOBA



Health Sciences Centre
Winnipeg

Specialized Seating Services
Rehabilitation Day Program

BODY MEASUREMENTS

	Body Measurements	Dimensions (in inches)		Notes
A	Hip width			To determine seat width
B	Trunk width			To determine backrest lateral contour width
	*Widest width In sitting (*if wider than hip width)			Measured from: _____ to _____
C	Thigh length	Right	Left	To determine seat depth
D	Lower leg length	Right	Left	To determine seat to floor height
E	Foot depth	Right	Left	To determine foot rest support depth
F	Trunk depth			To determine backrest lateral contour depth
G	PSIS height	Right	Left	To determine height for posterior pelvic supports in backrest
H	Elbow height	Right	Left	To determine armrest height
I	Inferior Angle of Scapula height	Right	Left	To determine backrest height for self-propellers and balanced sitters
J	Axilla height	Right	Left	To determine maximum allowable height for lateral supports
K	Shoulder height	Right	Left	To determine backrest height for dependent sitters and tilt in space users
L	Occipital height			To determine headrest height
M	Maximum sitting height			To determine overall sitting height for head clearance

820 Sherbrook Street (RR160E), Winnipeg, Manitoba R3A 1R9 / Phone 204-787-4266 / Fax 204-787-8637 jlbirt@hsc.mb.ca

An operating
division of the



Winnipeg Regional
Health Authority
Office régional de la
santé de Winnipeg

Affiliated
with the



UNIVERSITY
OF MANITOBA



Health Sciences Centre
Winnipeg

Specialized Seating Services
Rehabilitation Day Program

*N (can measure one or the other)	*ASIS to ASIS OR *Distance between undersurface of GT's (measured by palpating laterally from IT's until resting on this "shelf" either with body in supine and hips flexed, or sidelying)		To determine seat well width for lateral pelvic positioning
O	IT to IT		To determine distance necessary for bony immersion
P	Distance between outer surface of GT's		To determine outer limit of cushion well width
Q	Pelvic Contour Length (PCL) (Distance is measured from PSIS to 2" in front of IT's which corresponds with gluteal fold)		To determine cushion well length

820 Sherbrook Street (RR160E), Winnipeg, Manitoba R3A 1R9 / Phone 204-787-4266 / Fax 204-787-8637 jlbirt@hsc.mb.ca

An operating division of the



Winnipeg Regional Health Authority
Office régional de la santé de Winnipeg

Affiliated with the



UNIVERSITY OF MANITOBA



Health Sciences Centre
Winnipeg

Specialized Seating Services
Rehabilitation Day Program

CURRENT WHEELCHAIR AND SEATING COMPONENT SPECIFICATIONS

Specification	Description	
Type of wheelchair	Type of wheelchair base	Manual <input type="checkbox"/> Power <input type="checkbox"/> folding <input type="checkbox"/> rigid <input type="checkbox"/> dynamic tilt <input type="checkbox"/> Other:
	Name (manufacturer and model)	
	Supplier of wheelchair	
	Year supplied	
Seat base dimensions	Seat base width	Inches
	Essential seat width* (*if different from base dimensions)	Inches
	Seat base depth	Inches
	Essential seat depth* (*if different from base dimensions)	Inches
	Front seat to floor (STF) height	Inches
	Rear STF height	Inches
	Seat angle	Degrees
Wheelchair base dimensions	Overall wheelchair width	Inches
	Overall wheelchair depth	Inches
	Overall wheelchair height	Inches
Back cane specifications	Height	_____ inches Adjustable? Y <input type="checkbox"/> N <input type="checkbox"/>
	Angle	_____ degrees Adjustable? Y <input type="checkbox"/> N <input type="checkbox"/>
	Accessories	

820 Sherbrook Street (RR160E), Winnipeg, Manitoba R3A 1R9 / Phone 204-787-4266 / Fax 204-787-8637 jlbirt@hsc.mb.ca

An operating
division of the



Winnipeg Regional
Health Authority
Office régional de la
santé de Winnipeg

Affiliated
with the



UNIVERSITY
OF MANITOBA



Health Sciences Centre
Winnipeg

Specialized Seating Services
Rehabilitation Day Program

Specification	Description	
Foot hangers	rigid <input type="checkbox"/> swing away <input type="checkbox"/> removable <input type="checkbox"/>	
	Length (seat base to footplate)	_____ inches Adjustable? Y <input type="checkbox"/> N <input type="checkbox"/>
	Angle	_____ degrees Adjustable? Y <input type="checkbox"/> N <input type="checkbox"/>
Footplates	Type of material and accessories	
	Angle	_____ degrees Adjustable? Y <input type="checkbox"/> N <input type="checkbox"/>
	Width x length	_____ inches X _____ inches
Rear wheels	Diameter x width	_____ inches X _____ inches
	Type of wheel	
	Type of handrims (if manual)	
	Axle	Quick release? Y <input type="checkbox"/> N <input type="checkbox"/> Adjustable centre of gravity? Y <input type="checkbox"/> N <input type="checkbox"/>
	Camber	_____ Degrees
Rear tires	Type of tire	
Casters	Type of caster	
	Diameter x width	_____ inches X _____ inches
	Fork	Adjustable? Y <input type="checkbox"/> N <input type="checkbox"/>

820 Sherbrook Street (RR160E), Winnipeg, Manitoba R3A 1R9 / Phone 204-787-4266 / Fax 204-787-8637 jlbirt@hsc.mb.ca

An operating
division of the



Winnipeg Regional
Health Authority
Office régional de la
santé de Winnipeg

Affiliated
with the



UNIVERSITY
OF MANITOBA



Health Sciences Centre
Winnipeg

Specialized Seating Services
Rehabilitation Day Program

Specification	Description			
Armrests	Type of armrest	Desk length R <input type="checkbox"/> L <input type="checkbox"/>	Full length R <input type="checkbox"/> L <input type="checkbox"/>	
	Height	_____ inches		
	Removable?	Adjustable? Y <input type="checkbox"/> N <input type="checkbox"/>		
	Flip back?	Y <input type="checkbox"/> N <input type="checkbox"/>		
	Accessories			
Headrest	Type of headrest			
	Mounting hardware	Type of hardware: _____		
	Accessories	Adjustable? Y <input type="checkbox"/> N <input type="checkbox"/>		
Joystick	Style of joystick controller			
	Mount Location			
	Type of electronics			
	Additional switches			
Accessories	Laptray			
	Belts or straps			
	Clothing guards	Y <input type="checkbox"/> N <input type="checkbox"/>		
	Anti-tippers	Y <input type="checkbox"/> N <input type="checkbox"/>		
	Additional positioning accessories			
	Other			
Cushion	Commercial <input type="checkbox"/> Custom <input type="checkbox"/>	Removable? Y <input type="checkbox"/> N <input type="checkbox"/>		
	Name (manufacturer and model)			
	Width	Inches		
	Depth	Inches		
	Height	Inches		
	Positioning inserts			
	Additional accessories			

820 Sherbrook Street (RR160E), Winnipeg, Manitoba R3A 1R9 / Phone 204-787-4266 / Fax 204-787-8637 jlbirt@hsc.mb.ca

An operating
division of the



Winnipeg Regional
Health Authority
Office régional de la
santé de Winnipeg

Affiliated
with the



UNIVERSITY
OF MANITOBA

Specification	Description	
Backrest	Upholstery <input type="checkbox"/> Rigid backrest <input type="checkbox"/> Removable? Y <input type="checkbox"/> N <input type="checkbox"/>	
	Commercial <input type="checkbox"/> Custom <input type="checkbox"/>	
	Name (manufacturer and model)	
	Height	Inches
	Width	Inches
	Width between lateral contouring	Inches
	Angle of backrest	Degrees
	Positioning inserts	
	Type of mounting hardware	
	Additional accessories	
Seat to back configuration	Seat to back (STB) angle (use seat angle and back angle to determine this measurement)	Degrees
	Reclined STB (>90°) <input type="checkbox"/> Squeezed STB(<90°) <input type="checkbox"/> Static tilt <input type="checkbox"/>	

 Digital photos taken of: front side rear

820 Sherbrook Street (RR160E), Winnipeg, Manitoba R3A 1R9 / Phone 204-787-4266 / Fax 204-787-8637 jlbirt@hsc.mb.ca

 An operating
division of the

 Winnipeg Regional
Health Authority
Office régional de la
santé de Winnipeg

 Affiliated
with the

 UNIVERSITY
OF MANITOBA

D: NEW SOUTH WALES STATE SPINAL CORD INJURY SERVICE, SPINAL SEATING PROFESSIONAL DEVELOPMENT PROJECT

Used with permission from NSW State Spinal Cord Injury Service



Assessment form part 1 (prompts)

SEATING ASSESSMENT: INITIAL INTERVIEW		
Name:	MRN:	Date:
Present: <input type="checkbox"/> Client <input type="checkbox"/> Referrer : Others: <input type="checkbox"/> Clinician, profession: <input type="checkbox"/> Clinician, profession:		
Client's reason for attending assessment: > Why Are You Seeing The Client?" Get the client to state why they have come – don't make assumptions! > What do the referrer and other stakeholders want as an outcome? > Consider the client as the expert to their own well being and their own needs - find out what aspects of the seating and wheeled mobility system worked / did not work for the client and why		
Relevant Medical history:		
Medical Diagnosis , date of onset / injury and recent changes: Includes any recent changes/ loss of function		
Surgical history and considerations <u>Fractures and dislocations –</u> Note the causes, locations and their impact in seating / posture. Some common presentations that impact on seating are: > Hip dislocation or fractured femur – leg length difference impact on seat depth, detached femur encourages pelvic obliquity > Fractured tibia/ fibula– leg length difference impacts on footplate set up > Vertebrate subluxation or fractures– fixed lordosis, kyphosis, scoliosis, cervical hyper extension or flexion > Rib fractures – check spinal column for scoliosis instead of palpating rib cage. Take precaution when applying thoracic lateral support. <u>Orthopaedic / surgical interventions and precautions</u> > For example, shoulder problems will impact on range of motion and strength during wheelchair propulsion > Client may lean to one side to compensate for weakness or restriction <u>Orthotic / prosthetic device used</u> > Amputee –wheelchair set up when prosthesis is on or off. > Spinal orthotic brace may impact on seat angle and backrest options		
Pressure ulcer history: 1. When (did it happen / frequency), where (is the Pressure ulcer) and what (is the wound grade)? 2. How did it occur? 3. How was it managed?		
Spasm 1. Are there safety concerns due to spasm? 2. Are these postural and positioning concerns due to spasm? 3. Is client properly medically managed in these areas? Is client partaking in drug trials/ progressions that may impact on seating outcome?		
Skin Sensation: Taking into considerations of the level of spinal cord injury and the completeness/ incompleteness of the injury, the presence or absence of sensation may impact on: > pressure care management > hand function > balance > comfort and pain		
Pain History "Is the pain SEATING RELATED?" 1. When (does it start / frequency), where (is the pain) and what (is the pain like: dull burning, shape)? 2. How did the pain occur?		

3. How is it managed?	
4. Is client properly medically managed in these areas?	
Cardiovascular and respiratory status	
1. What are the implications of these on seating and mobility system?	
<ul style="list-style-type: none"> ➤ Take notes on exercise tolerance, endurance, stamina, and oedema issues. ➤ Are devices required for respiratory functions? Eg, Ventilator, Bipap 	
2. Is client susceptible to autonomic dysreflexia?	
Bowel and Bladder functions	
(Consider medical and nursing involvement)	
1. Does the client have issues with bowel and bladder incontinence? (skin and pressure risk)	
2. How long does client sit on the commode / toilet? (pressure risk)	
3. What continence aids are used? Where and When? (Eg, " bluey" over the pressure care cushion)	
4. Does client have a suprapubic catheter and where? (pelvic belt may cause pressure over the catheter site)?	
5. Does client have a neurogenic bowel or bladder?	
Vision: Adequate vision is required for safe independent mobility.	
Hearing: Compensatory strategies may be required for wheelchair training and independent mobility community environments	
Medical concerns regarding speech and swallowing:	
Weight:	Height:
Medications and allergies:	
Psychosocial status (observations / reports):	
Cognition and ability to learn new skill Normal/ impaired /descriptions	
Perceptual skills(motor planning and visual spatial orientation) Normal/ impaired/descriptions	
Communication skills, interpersonal and intrapersonal skills No difficulty / facilitator required / descriptions	
Judgement and safety awareness Sound / impaired/ unsafe	
Behaviour and personality traits Descriptions	
Motivation, attitude, tolerance to technology Descriptions	
Self image, the aesthetics and cosmetic preference towards wheeled mobility Descriptions	
Living arrangement:	
<input type="checkbox"/> High level residential care <input type="checkbox"/> Low level residential care <input type="checkbox"/> Respite <input type="checkbox"/> Home	
Social support: eg paid and unpaid carer	

Produced by NSW State Spinal Cord Injury Service, Spinal Seating Professional Development Program <http://www.health.nsw.gov.au/gmct/spinal/education.asp>
 Developed by Turnbull, Charisse. http://www.health.nsw.gov.au/resources/gmct/spinal/ssdpd/m02_sample_initial_interview_prompts_pdf.asp

2

Functional Issues: (How and where, how often, how easy / difficult, equipment needed)	
Self-maintenance:	
<u>Personal care:</u>	
<ul style="list-style-type: none"> ➤ toileting ➤ bathing ➤ eating ➤ grooming 	
<u>Domestic tasks:</u>	
meals preparation, washing, etc	
<u>Mobility, transfers and positioning:</u>	
(Bed / chair / car)	
<u>Type</u>	
<input type="checkbox"/> Hoist	<input type="checkbox"/> slide board
<input type="checkbox"/> standing transfer	<input type="checkbox"/> rail
<input type="checkbox"/> self lift	<input type="checkbox"/> walking frame
Others: _____	
Rest:	
Leisure:	
<ul style="list-style-type: none"> ➤ What is involved in these leisure activities: ➤ Indoors, outdoors, terrains ➤ Climate / daytime / night time ➤ In confined/ unpredictable/ wet areas ➤ Special accessories/tools requirement. 	
Productivity:	
<ul style="list-style-type: none"> ➤ Employment, schooling / studies, ➤ carer duties, voluntary work ➤ community participation 	
Environment	
Access to:	
<ul style="list-style-type: none"> ➤ Residence: ➤ Office/ workstations / work areas ➤ Terrain: ➤ Home backyard ➤ Suburb of residence / work: flat or steep terrain ➤ Rural areas: farm, dirt track 	
Transport:	
<ul style="list-style-type: none"> ➤ Vehicles / mode of transport: 	
Summary of issues /needs discussed:	
<ol style="list-style-type: none"> 1. Make a list of medical issues or physical attributes that will influence in the selection of seating and wheel mobility system. 2. Explore and discuss with the client the features of the seating and wheeled mobility required to carry out their activities of daily living. Record the discussion and proposed features. 3. List the environmental factors that will determine the features required in wheeled mobility. 	
Agreed features required in seating and wheeled mobility:	

NSW State Spinal Cord Injury Service	
Spinal Seating Professional Development Project	Assessment form part 1
Living arrangement: <input type="checkbox"/> High level residential care <input type="checkbox"/> Low level residential care <input type="checkbox"/> Respite <input type="checkbox"/> Home Others:	
Social support: eg, paid and unpaid carer	
Functional Issues:	
Self-maintenance:	
Personal care:	
Domestic tasks:	
Mobility, transfers and positioning:	
Type	
<input type="checkbox"/> Hoist	<input type="checkbox"/> slide board
<input type="checkbox"/> standing transfer	<input type="checkbox"/> rail
<input type="checkbox"/> self lift	<input type="checkbox"/> walking frame
Others:	
Rest:	
Leisure:	
Productivity:	
Environment	
Access:	
Terrain:	
Transport:	
Summary of issues or needs discussed:	
Agreed features required in seating and wheeled mobility:	







NSW State Spinal Cord Injury Service	
Spinal Seating Professional Development Project	Assessment form part 1
<p>Living arrangement:</p> <input type="checkbox"/> High level residential care <input type="checkbox"/> Low level residential care <input type="checkbox"/> Respite <input type="checkbox"/> Home Others:	
Social support: eg, paid and unpaid carer	
Functional Issues:	
<p>Self-maintenance:</p> <p>Personal care:</p> <p>Domestic tasks:</p> <p>Mobility, transfers and positioning:</p> <p>Type</p> <input type="checkbox"/> Hoist <input type="checkbox"/> slide board <input type="checkbox"/> self lift Others: <input type="checkbox"/> standing transfer <input type="checkbox"/> rail <input type="checkbox"/> walking frame	
Rest:	
Leisure:	
Productivity:	
Environment	
<p>Access:</p> <p>Terrain:</p> <p>Transport:</p>	
Summary of issues or needs discussed:	
Agreed features required in seating and wheeled mobility:	

POSTURE IN CURRENT SEATING SYSTEM					
ASSESSMENT FOR:			DATE:	Problems /Comments	
Pelvis	<i>Tilt (Side view)</i> <input type="checkbox"/> Neutral <input type="checkbox"/> Posterior <input type="checkbox"/> Anterior		<i>Obliquity (Frontal View)</i> <input type="checkbox"/> Neutral <input type="checkbox"/> Left Lower <input type="checkbox"/> Right Lower Lowered by:		<i>Rotation (Top view)</i> <input type="checkbox"/> Neutral <input type="checkbox"/> Left Forward <input type="checkbox"/> Right Forward
	Trunk	<i>Anterior / posterior</i> <input type="checkbox"/> Neutral <input type="checkbox"/> Thoracic Kyphosis <input type="checkbox"/> Lumbar Lordosis <input type="checkbox"/> lumbar C-curve flattening		<i>Scoliosis (Frontal View)</i> <input type="checkbox"/> Neutral <input type="checkbox"/> Convex Left <input type="checkbox"/> Convex Right Apex at:	
Hips		<i>Thigh to Trunk angle:</i> Left: _____ Right: _____ Degrees Degrees		<i>Position (Frontal View)</i> <input type="checkbox"/> Neutral <input type="checkbox"/> ABduct ⁿ <input type="checkbox"/> ADDuct ⁿ L / R L / R <input type="checkbox"/> External rotation : L / R <input type="checkbox"/> Internal rotation: L / R	
	Knees and Feet	<i>Thigh to lower leg angle :</i> Left _____ Right _____ Degrees Degrees		<i>Lower leg to foot angle:</i> Left _____ Right _____ Degrees Degrees <input type="checkbox"/> Plantar-flex <input type="checkbox"/> Plantar-flex. <input type="checkbox"/> Dorsi-flex <input type="checkbox"/> Dorsi-flex	
Head and neck		<i>Cervical curve (side view)</i> <input type="checkbox"/> Neutral <input type="checkbox"/> flexion <input type="checkbox"/> extension <input type="checkbox"/> cervical hyperextension (Chin poke)		<i>Neck position (Frontal View)</i> <input type="checkbox"/> Midline <input type="checkbox"/> Lat flexion: L / R <input type="checkbox"/> Rotation: L / R	
	Upper Limbs	<i>Shoulder positioning</i> <input type="checkbox"/> Level <input type="checkbox"/> asymmetry		<i>Elbow and forearm position</i> <input type="checkbox"/> arm support <input type="checkbox"/> no support	
			<i>Wrist and handgrip</i>		

Summary / comments:

Photo taken
 Consent obtained







Produced by NSW State Spinal Cord Injury Service, Spinal Seating Professional Development Program (<http://www.health.nsw.gov.au/gmct/spinal/education.asp>)
 Illustrations used with permission from Babinec, Michael, 2004 and Zollar, Jean Anne, 1996, adapted by Turnbull, Charisse, in 2008.
http://www.health.nsw.gov.au/resources/gmct/spinal/sspd/m03_mat_basic.pdf

SUPINE MAT ASSESSMENT																					
ASSESSMENT FOR:			DATE:		Problems /Comments																
Pelvis	<p>Tilt</p>  <p> <input type="checkbox"/> Neutral <input type="checkbox"/> Posterior <input type="checkbox"/> Anterior <input type="checkbox"/> fixed <input type="checkbox"/> flexible <input type="checkbox"/> corrects with effort (to neutral / partial correction) </p>		<p>Obliquity</p>  <p> <input type="checkbox"/> Neutral <input type="checkbox"/> Left Lower <input type="checkbox"/> Right Lower Lowered by: <input type="checkbox"/> fixed <input type="checkbox"/> flexible <input type="checkbox"/> corrects with effort (to neutral / partial correction) </p>		<p>Rotation</p>  <p> <input type="checkbox"/> Neutral <input type="checkbox"/> Left forward <input type="checkbox"/> Right forward <input type="checkbox"/> fixed <input type="checkbox"/> flexible <input type="checkbox"/> corrects with effort (to neutral / partial correction) </p>		Comments														
	Trunk	<p>Anterior / posterior</p>  <p> <input type="checkbox"/> Neutral <input type="checkbox"/> Thoracic Kyphosis <input type="checkbox"/> Lumbar Lordosis <input type="checkbox"/> lumbar C-curve flattening <input type="checkbox"/> fixed <input type="checkbox"/> flexible <input type="checkbox"/> corrects with effort (to neutral / partial correction) </p>		<p>Scoliosis</p>  <p> <input type="checkbox"/> Neutral <input type="checkbox"/> Convex Left <input type="checkbox"/> Convex Right Apex at: <input type="checkbox"/> fixed <input type="checkbox"/> flexible <input type="checkbox"/> corrects with effort (neutral/partial) </p>		<p>Rotation</p>  <p> <input type="checkbox"/> Neutral <input type="checkbox"/> Left forward <input type="checkbox"/> Right forward Forwarded by: <input type="checkbox"/> fixed <input type="checkbox"/> flexible <input type="checkbox"/> corrects with effort (to neutral / partial correction) </p>															
Lower extremities		Angles	<p>Range of motions or report observations:</p> <table border="1"> <thead> <tr> <th>LEFT</th> <th>Right</th> <th>Normal ROM</th> <th>Fixed / Flexible / Corrects with effort, Tone / Spasm that may impact on seating posture:</th> </tr> </thead> <tbody> <tr> <td></td> <td></td> <td>Simulate to 90°</td> <td></td> </tr> <tr> <td></td> <td></td> <td>30 to 180</td> <td></td> </tr> <tr> <td></td> <td></td> <td>30 -135</td> <td></td> </tr> </tbody> </table>		LEFT	Right	Normal ROM		Fixed / Flexible / Corrects with effort, Tone / Spasm that may impact on seating posture:			Simulate to 90°				30 to 180				30 -135	
	LEFT	Right	Normal ROM	Fixed / Flexible / Corrects with effort, Tone / Spasm that may impact on seating posture:																	
			Simulate to 90°																		
			30 to 180																		
		30 -135																			
<p>Trunk to thigh angle: Flex hip to 90° or a lesser angle till ASIS rolls / pelvic tilts</p> <p>Thigh to lower leg angle: with hip flex° at 90° or the trunk to thigh angle, extend knee from flexion till pelvis tilt / ASIS rolls.</p> <p>Lower leg to foot angle:</p>	<p>Hip Abduction / Adduction:</p>		<p>Hip external / internal rotation:</p>		<p>Foot inversion/ eversion:</p>																
<p>Cervical curve: Resting posture: <input type="checkbox"/> Neutral <input type="checkbox"/> Cervical Flexion <input type="checkbox"/> cervical hyperextension</p>	<p>Lateral flexion: Resting posture: <input type="checkbox"/> Neutral <input type="checkbox"/> left <input type="checkbox"/> right <input type="checkbox"/> fixed <input type="checkbox"/> flexible <input type="checkbox"/> corrects with effort</p>		<p>Rotation: Resting posture: <input type="checkbox"/> Neutral <input type="checkbox"/> left <input type="checkbox"/> right <input type="checkbox"/> fixed <input type="checkbox"/> flexible <input type="checkbox"/> corrects with effort</p>																		
<p>Shoulder PROM <input type="checkbox"/> Level <input type="checkbox"/> asymmetry</p>	<p>Elbow and forearm PROM</p>		<p>Wrist and hand Description:</p>																		

Summary / comments:

	<input type="checkbox"/> Photo taken
<input type="checkbox"/>	Consent obtained

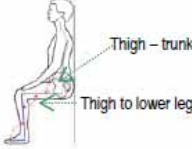







Produced by NSW State Spinal Cord Injury Service, Spinal Seating Professional Development Program (<http://www.health.nsw.gov.au/gmct/spinal/education.asp>) 2
 Illustrations used with permission from Babinec, Michael, 2004 and Zollar, Jean Anne, 1996, adapted by Turnbull, Charisse, in 2008.
http://www.health.nsw.gov.au/resources/gmct/spinal/ssdpdp/m03_mat_basic_pdf.asp

SITTING MAT ASSESSMENT				
ASSESSMENT FOR:		DATE:		SIMULATION & OUTCOME: (Describe direction and location of forces applied)
Balance: <input type="checkbox"/> Hands- free sitter <input type="checkbox"/> Hands dependant sitter <input type="checkbox"/> *Propped sitter*		(* for advance skill clinician / specialist only)		
Pelvis	Tilt (Side view)  <input type="checkbox"/> Neutral <input type="checkbox"/> Posterior <input type="checkbox"/> Anterior	Obliquity (Frontal View)  <input type="checkbox"/> Neutral <input type="checkbox"/> Left Lower <input type="checkbox"/> Right Lower Lowered by:	Rotation (Top view)  <input type="checkbox"/> Neutral <input type="checkbox"/> Left forward <input type="checkbox"/> Right forward	Accommodations / corrections: Outcomes:
	Trunk	Anterior / posterior  <input type="checkbox"/> Neutral <input type="checkbox"/> Thoracic Kyphosis <input type="checkbox"/> Lumbar Lordosis <input type="checkbox"/> lumbar C-curve flattening <input type="checkbox"/> fixed <input type="checkbox"/> flexible <input type="checkbox"/> corrects with effort (to neutral / partial correction)	Scoliosis (Frontal View)  <input type="checkbox"/> Neutral <input type="checkbox"/> Convex Left <input type="checkbox"/> Convex Right Apex at: <input type="checkbox"/> fixed <input type="checkbox"/> flexible <input type="checkbox"/> corrects with effort (neutral/partial)	
Lower extremities		Initial sitting angles  Thigh – trunk: Thigh to lower leg:	Position (Frontal View)  <input type="checkbox"/> Neutral <input type="checkbox"/> ABduct ⁿ <input type="checkbox"/> ADduct ⁿ L / R L / R <input type="checkbox"/> External rotation : L / R <input type="checkbox"/> Internal rotation: L / R	Windswept (Frontal View)  <input type="checkbox"/> Neutral <input type="checkbox"/> Left <input type="checkbox"/> Right
	Head and neck	Cervical curve (side view)	Neck position (Frontal View)	Control
Upper Extremities		Shoulder positioning <input type="checkbox"/> Level <input type="checkbox"/> asymmetry Describe:	Elbow and forearm position Describe:	Hand and wrist positioning Describe:

Summary / comments:





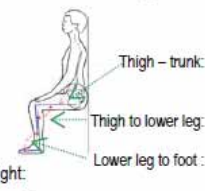
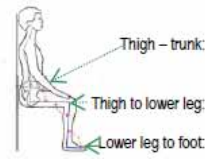

	<input type="checkbox"/> Photo taken
<input type="checkbox"/>	Consent obtained

Produced by NSW State Spinal Cord Injury Service, Spinal Seating Professional Development Program (<http://www.health.nsw.gov.au/gmct/spinal/education.asp>) 3
 Illustrations used with permission from Babinec, Michael, 2004 and Zollar, Jean Anne, 1996, adapted by Turnbull, Charisse, in 2008.
http://www.health.nsw.gov.au/resources/gmct/spinal/sspd/m03_mat_basic_pdf.asp

POSTURE IN CURRENT SEATING SYSTEM				Problems /Comments																																				
ASSESSMENT FOR:		DATE:																																						
Pelvis	Tilt (Side view)  <input type="checkbox"/> Neutral <input type="checkbox"/> Posterior <input type="checkbox"/> Anterior Describe:	Obliquity (Frontal View)  <input type="checkbox"/> Neutral <input type="checkbox"/> Left Lower <input type="checkbox"/> Right Lower Lowered by:	Rotation (Top view)  <input type="checkbox"/> Neutral <input type="checkbox"/> Left Forward <input type="checkbox"/> Right Forward Forwarded by:																																					
	Trunk	Anterior / posterior  <input type="checkbox"/> Neutral <input type="checkbox"/> Thoracic Kyphosis <input type="checkbox"/> Lumbar Lordosis <input type="checkbox"/> Lumbar C-curve flattening	Scoliosis (Frontal View)  <input type="checkbox"/> Neutral <input type="checkbox"/> Convex Left <input type="checkbox"/> Convex Right Apex at:		Rotation (Top view)  <input type="checkbox"/> Neutral <input type="checkbox"/> L forward <input type="checkbox"/> R forward																																			
	Hips	Thigh to Trunk angle: Left: _____ Degrees Right: _____ Degrees	Position (Frontal View)  <input type="checkbox"/> Neutral <input type="checkbox"/> ABduct ^a <input type="checkbox"/> ADduct ^a L / R L / R <input type="checkbox"/> External rotation : L / R <input type="checkbox"/> Internal rotation: L / R		Windswept (Top View)  <input type="checkbox"/> Neutral <input type="checkbox"/> Left <input type="checkbox"/> Right		Left: <u>Angles</u>  Right: 																																	
Knees and Feet	Thigh to lower leg angle: Left _____ Degrees Right _____ Degrees	Lower leg to foot angle: Left _____ Degrees Right _____ Degrees <input type="checkbox"/> Plantar-flex <input type="checkbox"/> Plantar-flex. <input type="checkbox"/> Dorsi-flex <input type="checkbox"/> Dorsi-flex	Foot position: Left <input type="checkbox"/> WFL <input type="checkbox"/> Inversion <input type="checkbox"/> Eversion Right <input type="checkbox"/> WFL <input type="checkbox"/> Inversion <input type="checkbox"/> Eversion																																					
Head and neck	Cervical curve (side view) <input type="checkbox"/> Neutral <input type="checkbox"/> flexion <input type="checkbox"/> extension <input type="checkbox"/> cervical hyperextension (Chin poke)	Neck position (Frontal View) <input type="checkbox"/> Midline <input type="checkbox"/> Lat flexion: L / R <input type="checkbox"/> Rotation: L / R	Control <input type="checkbox"/> independent head control / and full ROM <input type="checkbox"/> restricted head control <input type="checkbox"/> restricted ROM: <input type="checkbox"/> absent head control																																					
Upper Limbs	Shoulder positioning <input type="checkbox"/> Level <input type="checkbox"/> asymmetry <table border="1"> <tr> <td></td> <td>Left</td> <td>Right</td> </tr> <tr> <td>Elevated</td> <td><input type="checkbox"/></td> <td><input type="checkbox"/></td> </tr> <tr> <td>Depressed</td> <td><input type="checkbox"/></td> <td><input type="checkbox"/></td> </tr> <tr> <td>Retracted</td> <td><input type="checkbox"/></td> <td><input type="checkbox"/></td> </tr> <tr> <td>Subluxed</td> <td><input type="checkbox"/></td> <td><input type="checkbox"/></td> </tr> <tr> <td>Ext rotation</td> <td><input type="checkbox"/></td> <td><input type="checkbox"/></td> </tr> <tr> <td>Int.rotation</td> <td><input type="checkbox"/></td> <td><input type="checkbox"/></td> </tr> </table>		Left	Right	Elevated	<input type="checkbox"/>	<input type="checkbox"/>	Depressed	<input type="checkbox"/>	<input type="checkbox"/>	Retracted	<input type="checkbox"/>	<input type="checkbox"/>	Subluxed	<input type="checkbox"/>	<input type="checkbox"/>	Ext rotation	<input type="checkbox"/>	<input type="checkbox"/>	Int.rotation	<input type="checkbox"/>	<input type="checkbox"/>	Elbow and forearm position <input type="checkbox"/> arm support <input type="checkbox"/> no support Elbow flexion: (0°- 150°) Left: _____ Right: _____ Supination: (0°-90°) Left: _____ Right: _____ Pronation: (0°-90°) Left: _____ Right: _____ Position Description:	Wrist and handgrip Wrist position: L R Flexion / extension: <input type="checkbox"/> <input type="checkbox"/> Deviation (ulnar/ radial): <input type="checkbox"/> <input type="checkbox"/> <table border="1"> <tr> <td>Hand grip</td> <td>left</td> <td>right</td> </tr> <tr> <td>Palmer /gross grip</td> <td><input type="checkbox"/></td> <td><input type="checkbox"/></td> </tr> <tr> <td>Lateral pinch</td> <td><input type="checkbox"/></td> <td><input type="checkbox"/></td> </tr> <tr> <td>Tripot pinch</td> <td><input type="checkbox"/></td> <td><input type="checkbox"/></td> </tr> <tr> <td>Nil grip</td> <td><input type="checkbox"/></td> <td><input type="checkbox"/></td> </tr> </table>	Hand grip	left	right	Palmer /gross grip	<input type="checkbox"/>	<input type="checkbox"/>	Lateral pinch	<input type="checkbox"/>	<input type="checkbox"/>	Tripot pinch	<input type="checkbox"/>	<input type="checkbox"/>	Nil grip	<input type="checkbox"/>	<input type="checkbox"/>	
	Left	Right																																						
Elevated	<input type="checkbox"/>	<input type="checkbox"/>																																						
Depressed	<input type="checkbox"/>	<input type="checkbox"/>																																						
Retracted	<input type="checkbox"/>	<input type="checkbox"/>																																						
Subluxed	<input type="checkbox"/>	<input type="checkbox"/>																																						
Ext rotation	<input type="checkbox"/>	<input type="checkbox"/>																																						
Int.rotation	<input type="checkbox"/>	<input type="checkbox"/>																																						
Hand grip	left	right																																						
Palmer /gross grip	<input type="checkbox"/>	<input type="checkbox"/>																																						
Lateral pinch	<input type="checkbox"/>	<input type="checkbox"/>																																						
Tripot pinch	<input type="checkbox"/>	<input type="checkbox"/>																																						
Nil grip	<input type="checkbox"/>	<input type="checkbox"/>																																						







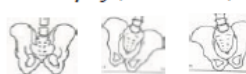

Produced by NSW State Spinal Cord Injury Service, Spinal Seating Professional Development Program
 (<http://www.health.nsw.gov.au/gmct/spinal/education.asp>)
 Illustrations used with permission from Babinec, Michael, 2004 and Zollar, Jean Anne, 1996, adapted by Turnbull, Charisse, in 2008.

	<input type="checkbox"/> Photo taken
<input type="checkbox"/>	Consent obtained

SUPINE ASSESSMENT																																																						
ASSESSMENT FOR:			DATE:	Problems /Comments																																																		
Pelvis	Tilt  <input type="checkbox"/> Neutral <input type="checkbox"/> Posterior <input type="checkbox"/> Anterior <input type="checkbox"/> fixed <input type="checkbox"/> flexible <input type="checkbox"/> corrects with effort (to neutral / partial correction)		Obliquity  <input type="checkbox"/> Neutral <input type="checkbox"/> Left Lower <input type="checkbox"/> Right Lower Lowered by: <input type="checkbox"/> fixed <input type="checkbox"/> flexible <input type="checkbox"/> corrects with effort (to neutral / partial correction)		Rotation  <input type="checkbox"/> Neutral <input type="checkbox"/> Left forward <input type="checkbox"/> Right forward Forwarded by: <input type="checkbox"/> fixed <input type="checkbox"/> flexible <input type="checkbox"/> corrects with effort (to neutral / partial correction)	Comments																																																
	Trunk	Anterior / posterior  <input type="checkbox"/> Neutral <input type="checkbox"/> Thoracic Kyphosis <input type="checkbox"/> Lumbar Lordosis <input type="checkbox"/> lumbar C-curve flattening <input type="checkbox"/> fixed <input type="checkbox"/> flexible <input type="checkbox"/> corrects with effort (to neutral / partial correction)		Scoliosis  <input type="checkbox"/> Neutral <input type="checkbox"/> Convex Left <input type="checkbox"/> Convex Right Apex at: <input type="checkbox"/> fixed <input type="checkbox"/> flexible <input type="checkbox"/> corrects with effort (to neutral / partial correction)			Rotation  <input type="checkbox"/> Neutral <input type="checkbox"/> Left forward <input type="checkbox"/> Right forward Forwarded by: <input type="checkbox"/> fixed <input type="checkbox"/> flexible <input type="checkbox"/> corrects with effort (to neutral / partial correction)																																															
Lower extremities		Range of motions or report observations: <table border="1"> <thead> <tr> <th></th> <th>LEFT</th> <th>Right</th> <th>Normal ROM</th> </tr> </thead> <tbody> <tr> <td>A Hip flexion with knee extension</td> <td></td> <td></td> <td>0-90</td> </tr> <tr> <td>B Maximum hip flexion with knee bent relaxed</td> <td></td> <td></td> <td>0-130</td> </tr> <tr> <td>C Trunk to thigh angle: Flex hip to 90° or a lesser angle when ASIS rolls / pelvic tilts</td> <td></td> <td></td> <td>Simulate to 90°</td> </tr> <tr> <td>D Thigh to lower leg angle: with hip flexⁿ at 90° or as in C, extend knee from flexion till pelvis tilt / ASIS rolls.</td> <td></td> <td></td> <td>30 to 180</td> </tr> <tr> <td>F Hip Abduction in position C&D</td> <td></td> <td></td> <td>0-45</td> </tr> <tr> <td>F Hip Adduction in position C&D</td> <td></td> <td></td> <td>0-30</td> </tr> <tr> <td>G Hip External Rotation in position C&D</td> <td></td> <td></td> <td>0-45</td> </tr> <tr> <td>H Hip Internal Rotation in position C&D</td> <td></td> <td></td> <td>0-45</td> </tr> <tr> <td>I Lower leg to foot angle: positioned in C & D</td> <td></td> <td></td> <td>30-135</td> </tr> <tr> <td>J Foot inversion in position C&D</td> <td></td> <td></td> <td></td> </tr> <tr> <td>K Foot eversion in position C&D</td> <td></td> <td></td> <td></td> </tr> </tbody> </table>				LEFT	Right	Normal ROM	A Hip flexion with knee extension			0-90	B Maximum hip flexion with knee bent relaxed			0-130	C Trunk to thigh angle: Flex hip to 90° or a lesser angle when ASIS rolls / pelvic tilts			Simulate to 90°	D Thigh to lower leg angle: with hip flex ⁿ at 90° or as in C, extend knee from flexion till pelvis tilt / ASIS rolls.			30 to 180	F Hip Abduction in position C&D			0-45	F Hip Adduction in position C&D			0-30	G Hip External Rotation in position C&D			0-45	H Hip Internal Rotation in position C&D			0-45	I Lower leg to foot angle: positioned in C & D			30-135	J Foot inversion in position C&D				K Foot eversion in position C&D				report observations: Fixed / Flexible / Corrects with effort, Tone / Spasm that may impact on seating posture:	
		LEFT	Right	Normal ROM																																																		
	A Hip flexion with knee extension			0-90																																																		
	B Maximum hip flexion with knee bent relaxed			0-130																																																		
	C Trunk to thigh angle: Flex hip to 90° or a lesser angle when ASIS rolls / pelvic tilts			Simulate to 90°																																																		
	D Thigh to lower leg angle: with hip flex ⁿ at 90° or as in C, extend knee from flexion till pelvis tilt / ASIS rolls.			30 to 180																																																		
	F Hip Abduction in position C&D			0-45																																																		
	F Hip Adduction in position C&D			0-30																																																		
	G Hip External Rotation in position C&D			0-45																																																		
	H Hip Internal Rotation in position C&D			0-45																																																		
	I Lower leg to foot angle: positioned in C & D			30-135																																																		
J Foot inversion in position C&D																																																						
K Foot eversion in position C&D																																																						
Head and neck	Cervical curve: Resting posture: <input type="checkbox"/> Neutral <input type="checkbox"/> Cervical Flexion <input type="checkbox"/> cervical hyperextension AROM Flex ⁿ _____ Ext ⁿ _____		Lateral flexion: Resting posture: <input type="checkbox"/> Neutral <input type="checkbox"/> left <input type="checkbox"/> right <input type="checkbox"/> fixed <input type="checkbox"/> flexible <input type="checkbox"/> corrects with effort AROM Left: _____ Right: _____		Rotation: Resting posture: <input type="checkbox"/> Neutral <input type="checkbox"/> left <input type="checkbox"/> right <input type="checkbox"/> fixed <input type="checkbox"/> flexible <input type="checkbox"/> corrects with effort AROM Left: _____ Right: _____																																																	
	Upper extremities	Shoulder PROM <input type="checkbox"/> Level <input type="checkbox"/> asymmetry PROM L R Flexion (to 90°) Extension Abduction Adduction Ext rotation Int rotation		Elbow and forearm PROM Elbow flex ⁿ : PROM (0°- 150°) Left: _____ Right: _____ Supination: PROM (0°-90°) Left: _____ Right: _____ Supination: PROM (0°-90°) Left: _____ Right: _____ Description:		Wrist and hand Description:																																																

Produced by NSW State Spinal Cord Injury Service, Spinal Seating Professional Development Program
 (<http://www.health.nsw.gov.au/gmct/spinal/education.asp>)
 Illustrations used with permission from Babinec, Michael, 2004 and Zollar, Jean Anne, 1996, adapted by Turnbull, Charisse, in 2008.

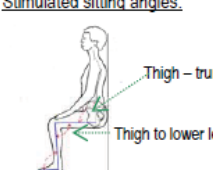
 Photo taken
 Consent obtained

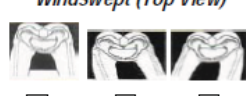
SITTING ASSESSMENT ON PLINTH				
ASSESSMENT FOR:		DATE:		SIMULATION & OUTCOME: (Describe direction and location of forces applied)
Balance: <input type="checkbox"/> Hands- free sitter <input type="checkbox"/> Hands dependant sitter <input type="checkbox"/> *Propped sitter* <small>(* for advance skill clinician / specialist only)</small>				
Pelvis	Tilt (Side view)  <input type="checkbox"/> Neutral <input type="checkbox"/> Posterior <input type="checkbox"/> Anterior <input type="checkbox"/> fixed <input type="checkbox"/> flexible <input type="checkbox"/> corrects with effort: (to neutral / partial correction)	Obliquity (Frontal View)  <input type="checkbox"/> Neutral <input type="checkbox"/> Left Lowered <input type="checkbox"/> Right Lowered Lowered by: <input type="checkbox"/> fixed <input type="checkbox"/> flexible <input type="checkbox"/> corrects with effort: (to neutral / partial correction)	Rotation (Top view)  <input type="checkbox"/> Neutral <input type="checkbox"/> Left Forward <input type="checkbox"/> Right Forward Forwarded by: <input type="checkbox"/> fixed <input type="checkbox"/> flexible <input type="checkbox"/> corrects with effort: (to neutral / partial correction)	Accommodations / corrections: Outcomes:
	Trunk	Anterior / posterior  <input type="checkbox"/> Neutral <input type="checkbox"/> Thoracic Kyphosis <input type="checkbox"/> Lumbar Lordosis <input type="checkbox"/> lumbar C-curve flattening <input type="checkbox"/> fixed <input type="checkbox"/> flexible <input type="checkbox"/> corrects with effort: (to neutral / partial correction)	Scoliosis (Frontal View)  <input type="checkbox"/> Neutral <input type="checkbox"/> Convex Left <input type="checkbox"/> Convex Right Apex at: <input type="checkbox"/> fixed <input type="checkbox"/> flexible <input type="checkbox"/> corrects with effort: (to neutral / partial correction)	Rotation (Top view)  <input type="checkbox"/> Neutral <input type="checkbox"/> L forward <input type="checkbox"/> R forward Forwarded by: <input type="checkbox"/> fixed <input type="checkbox"/> flexible <input type="checkbox"/> corrects with effort: (to neutral / partial correction)
Lower extremities	Initial sitting angles  Thigh – trunk: Thigh to lower leg: Stimulated sitting angles:  Thigh – trunk: Thigh to lower leg:	Position (Frontal View)  <input type="checkbox"/> Neutral <input type="checkbox"/> ABduct* <input type="checkbox"/> ADduct* L / R..... L / R <input type="checkbox"/> External rotation : L / R <input type="checkbox"/> Internal rotation: L / R <input type="checkbox"/> fixed <input type="checkbox"/> flexible <input type="checkbox"/> corrects with effort: (to neutral / partial correction)	Windswept (Top View)  <input type="checkbox"/> Neutral <input type="checkbox"/> Left <input type="checkbox"/> Right <input type="checkbox"/> fixed <input type="checkbox"/> flexible <input type="checkbox"/> corrects with effort: (to neutral / partial correction)	Accommodations / corrections: Outcomes:
	Head and neck	Cervical curve (side view) <input type="checkbox"/> Neutral <input type="checkbox"/> flexion <input type="checkbox"/> extension <input type="checkbox"/> cervical hyperextension (Chin poke) <input type="checkbox"/> fixed <input type="checkbox"/> flexible <input type="checkbox"/> corrects with effort: (to neutral / partial correction)	Neck position (Frontal View) <input type="checkbox"/> Midline <input type="checkbox"/> Lat flexion: L / R <input type="checkbox"/> Rotation: L / R <input type="checkbox"/> fixed <input type="checkbox"/> flexible <input type="checkbox"/> corrects with effort: (to neutral / partial correction)	Control <input type="checkbox"/> independent head control / and full ROM <input type="checkbox"/> restricted head control <input type="checkbox"/> restricted ROM: <input type="checkbox"/> absent head control
Upper Extremities	Shoulder positioning <input type="checkbox"/> Level <input type="checkbox"/> asymmetry Describe:	Elbow and forearm position Describe:	Hand and wrist positioning Describe:	Accommodations / corrections: Outcomes:

Produced by NSW State Spinal Cord Injury Service, Spinal Seating Professional Development Program
 (<http://www.health.nsw.gov.au/gmct/spinal/education.asp>)
 Illustrations used with permission from Babinec, Michael, 2004 and Zollar, Jean Anne, 1996, adapted by Turnbull, Charisse, in 2008.

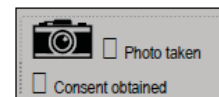

Body Measurement

Drawing used with permission from
Jean Anne Zollar, 1996,
adapted by
Charisse Turnbull 2008.

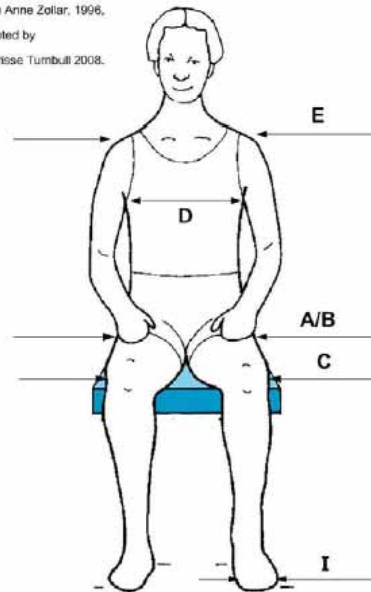

✓ : Usefulness for this type of wheeled mobility

Please also refer to Module 5 – description of seating and wheeled mobility for terminology used in the column “purposes”.

Purposes of and prompts for Body Measurements				
Body measurements are conducted on the client with:				
Trunk to thigh angle: (based in MAT outcome)		Thigh to lower leg angle:		
	Linear body measurements:	MWC	PWC	Purposes: To assist in determining:
A	Hip width:	✓	✓	cushion width, seat width or width between side hip supports
B	GT width:			cushion size for “GT- loading” type of cushion such as Jay 2 and Jay deep
C	External knee width/ Width across knees	✓	✓	seat width and footplate hanger style
D	Chest width:	✓	✓	- distance between thoracic lateral support if required - width between tall back cane/ back support to ensure free upper limb movement for MWC propulsion
E	Shoulder width	✓	✓	minimum distance between arm supports if upper limb positioning and arm supports are required
I	Foot width: (also consider shoe width for tapered frame)	✓		minimum width for tapered frame/ single foot support size. (X2 for left and right)

Produced by NSW State Spinal Cord Injury Service, Spinal Seating Professional Development Program (<http://www.health.nsw.gov.au/gmct/spinal/education.asp>)

Illustrations used with permission from Zollar, Jean Anne, 1996, adapted by Turnbull, Charisse, in 2008.

http://www.health.nsw.gov.au/resources/gmct/spinal/ssdp/m04_body_measurement_form_prompt.pdf

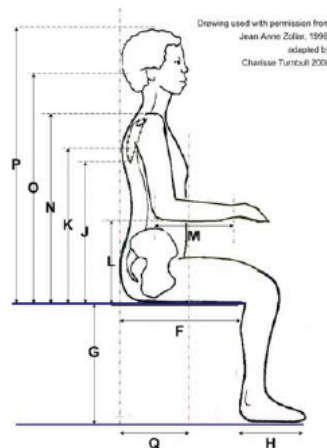

✓ : Usefulness for this type of wheeled mobility

F	Thigh depth: (rearrest point / scarum to popliteal fossa)	✓	✓	seat depth by deducting: - 25mm if thigh to lower leg angle is $>90^\circ$ - 50mm if thigh to lower leg angle is $<90^\circ$ (prevent seat base digging into calf muscles)
G	Lower leg length: (Popliteal fossa to heel)	✓	✓	foot support to seat base length by: - deducting front cushion height - add shoe heel height
H	Foot depth: (heel to toe & with shoe)	✓	✓	- foot support (footplate) style/size/ accessories required considering the castor spins and footplate location
I	Foot width: (also consider shoe width for tapered frame)	✓		minimum width for tapered frame/ single foot support size. (X2 for left and right)
J	Scapula height: (Seat surface to inferior angle of scapula) For hands free / hands dependent sitter only	✓		maximum back cane/ back support height from seat surface for free scapulae movement in MWC propulsion
K	Axilla height: (Seat surface to axilla)	✓	✓	thoracic lateral support height from seat surface. Maximum height allowed should be 25mm less of this measurement to prevent impingement of axillary nerve.
L	Elbow height: (Seat surface to hanging elbow)	✓	✓	arm support height or lap tray from seat surface
M	Forearm Depth:	✓	✓	armrest pad size and approximate joystick mounting position.
N	Shoulder height: (Seat surface to shoulder)		✓	- approximate backrest height from seat surface for those who use tilt in space for pressure management. - minimum backrest height from seat surface for chest harness to provide effective line of pull.
O	Occipital height: (Seat surface to occipital ridge)		✓	Head & neck support height from seat surface, particularly important for those with weak /no head control
P	Maximum sitting height: (Seat surface to top of head)	✓	✓	if the wheeled mobility system can access transport/ vehicles. Overall head to floor height = P + cushion height at ITs + seat base to floor height
Q	Trunk depth: (for backrest style & thoracic laterals)			depth of thoracic lateral support required to provide optimum support. It should be 2/3 of trunk depth for 'hands dependant sitters'.

Produced by NSW State Spinal Cord Injury Service, Spinal Seating Professional Development Program (<http://www.health.nsw.gov.au/gmct/spinal/education.asp>)
Illustrations used with permission from Zollar, Jean Anne, 1996, adapted by Turnbull, Chansse, in 2008.
http://www.health.nsw.gov.au/resources/gmct/spinal/ssdp/m04_body_measurement_form_prompt.pdf.asp

2

NSW SSCIS NSW State Spinal Cord Injury Service
Spinal Seating Professional Development Project

Drawing used with permission from:
 Jean Anne Zollar, 1996,
 adapted by
 Charisse Turnbull, 2008.

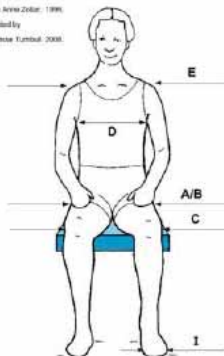

Assessment form part 3: body measurement

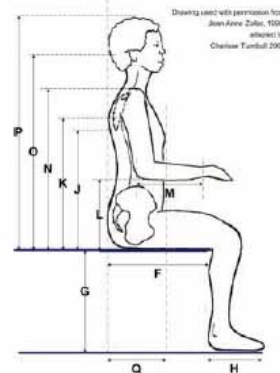

BODY MEASUREMENTS					
Assessment for:			Date:		
Body measurements are conducted on the client with:					
Trunk to thigh angle:			Thigh to lower leg angle:		
	Linear body measurements	MVC	PVC	Dimensions: (State in centimetres and/or inches)	
A	Hip width:	✓✓	✓✓		
B	GT width: (for GT width specific cushion)				
C	External knee width/ Width across knees	✓	✓		
D	Chest width:	✓✓	✓✓		
E	Shoulder width	✓	✓		
F	Thigh depth: (rear-rest point / sacrum to popliteal fossa)	✓✓	✓✓	L:	R:
G	Lower leg length: (Popliteal fossa to heel of the foot) <i>Note foot wear heel height:</i>	✓✓	✓✓	L:	R:
H	Foot depth: (heel to toe & with shoe)	✓	✓	L:	R:
I	Foot width: (also consider shoe width for tapered frame)	✓		L:	R:
J	Scapula height: (Seat surface to inferior angle of scapula) For hands free / hands dependent sitter only	✓		L:	R:
K	Axilla height: (Seat surface to axilla)	✓	✓	L:	R:
L	Elbow height: (Seat surface to hanging elbow)	✓	✓✓	L:	R:
M	Forearm Depth:	✓	✓✓	L:	R:
N	Shoulder height: (Seat surface to shoulder)		✓	L:	R:
O	Occipital height: (Seat surface to occipital ridge)		✓		
P	Maximum sitting height: (Seat surface to top of head)	✓	✓		
Q	Trunk depth: (for backrest style & thoracic laterals)				

✓: Usefulness for this type of wheeled mobility

Produced by NSW State Spinal Cord Injury Service, Spinal Seating Professional Development Program (<http://www.health.nsw.gov.au/gmct/spinal/education.asp>)

Illustrations used with permission from Zollar, Jean Anne, 1996, adapted by Turnbull, Charisse, in 2008.

http://www.health.nsw.gov.au/resources/gmct/spinal/ssdpdp/m04_body_measurement_form_pdf.asp

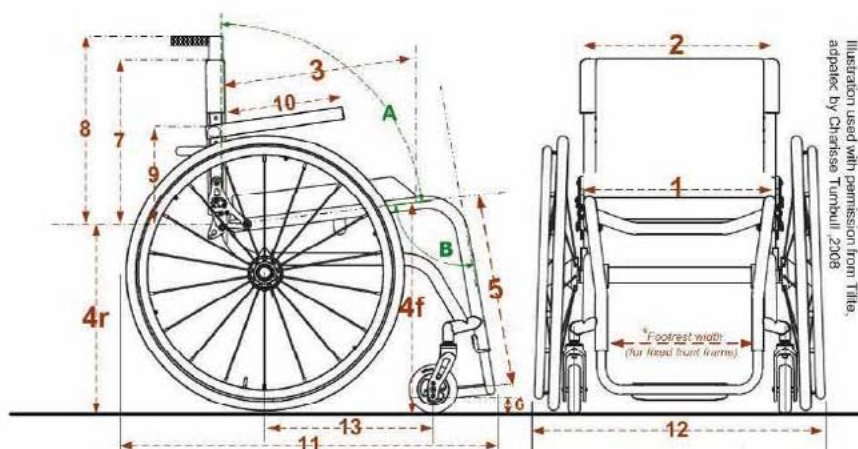

ASSESSMENT FOR:		Funding:	DATE:
Cushion/seat base:	Size & height	Age / condition:	
Back support:	Size & height	Age / condition:	
Wheelchair:	Frame type & style:	Age / condition:	
1	Seat width :	Distance between outermost parts of the seat	
2	Back support width: <i>(if different to seat width)</i>	Distance between outermost parts of back support. Including solid back support and thoracic support pads.	
3	Seat depth:	Distance between the front of the seat to the back support in the seat	
4	Seat surface height:	Height of seat above floor. Measure for front and rear.	
5	Footplate / foot support to seat:	Distance between footplate /support to seat base	
6	Footplate / foot support clearance from floor:	Height of the clear space between the lowest point of the foot support / footplates	
7	Back support height/ backrest upholstery:	Top of back support to seat base	
8	Back cane metal work height:	Top of back cane to seat base	
9	Armrest/ arm support height:	Top of armrest to seat base	
10	Armrest/ arm support length:	Back cane to the end of arm support	
11	Overall length:	Consider this measurement for access and transport	
12	Overall width	Consider this measurement for access and transport	
13	Rear wheel axle to front caster mount:	Measure the shortest distance between the rear wheel to caster when it is in a forward trailing position.	

NSW SSCIS NSW State Spinal Cord Injury Service		Spinal Seating Professional Development Project		Assessment form part 4 (MWC) - Prompts	
A	Seat to back support angle: (Degrees)	To reflect the true seat to back support angle measure from the middle of the backrest surface to seat base			
B	Leg rest to seat angle: (Degrees)	For most wheelchairs makes, "footrest hanger /front rigger angle" is calculated by 180° minus the leg rest to seat angle.			
Arm support, clothing guards: <i>single / dual mount solid/ fabric guards</i>		Leg rest & hanger type: <i>60/70/80/90 degree, centre mount, elevation, fixed /swing away</i>		*Foot support type: <i>angle adjustment, ankle huggers, heel loops</i>	
Rear wheels size and type:		Wheel release and hubs:		Casters size and type:	
Tyres:		Wheel lock / brake:		Suspension:	
Push rims:		Wheel Camber: <input type="checkbox"/> Yes <input type="checkbox"/> No Degree:		Tilt in space: <input type="checkbox"/> Yes <input type="checkbox"/> No Tilt range: ° to °	
Other seating /mobility components /devices:			Issues identified / comments		

MANUAL WHEELCHAIR AND SEATING SPECIFICATIONS			
ASSESSMENT FOR:		Funding:	DATE:
Cushion/seat base:	Size & height:	Age / condition:	
Back support:	Size & height:	Age / condition:	
Wheelchair:	<p>Illustration used with permission from Tiltite, adapted by Charisse Turnbull, 2008</p>		
Frame type & style:			
Age:			
Condition:			
1	Seat width :		
2	Back support width: <i>(if different to seat width)</i>		
3	Seat depth:		
4	Seat surface height:	Front:	Rear:
5	Footplate / foot support to seat:		
6	Footplate / foot support clearance from floor:		
7	Back support height/ backrest upholstery:		
8	Back cane metal work height:		
9	Armrest/ arm support height:	Left	Right
10	Armrest/ arm support length:	Left	Right
11	Overall length:		
12	Overall width		
13	Rear wheel axle to front caster mount:		
A	Seat to back support angle:	Degrees:	
B	Leg rest to seat surface angle:	Degrees:	
Arm support, clothing guards:	Leg rest & hanger type:	*Foot support type:	
Rear wheels size and type:	Wheel release and hubs:	Casters size and type:	
Tyres:	Wheel lock / brake:	Suspension:	
Push rims:	Wheel Camber: <input type="checkbox"/> Yes <input type="checkbox"/> No Degrees:	Tilt in space: <input type="checkbox"/> Yes <input type="checkbox"/> No Tilt range: ° to °	
Other seating /mobility components /devices:		Issues identified / comments	

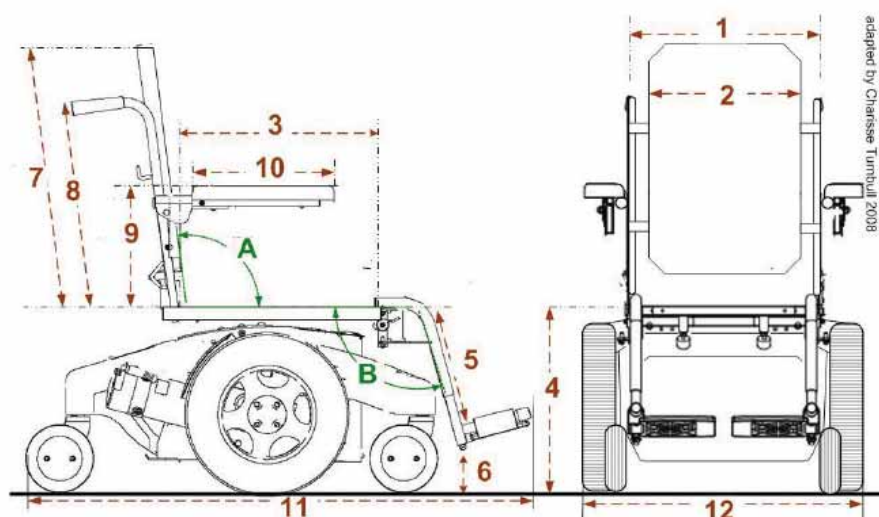

ASSESSMENT FOR:		Funding:	DATE:
Cushion/seat base:	Size & height	Age / condition:	
Back support:	Size & height	Age / condition:	
Wheelchair:	Power base & motor:	Age / condition:	
1	Seat width :	Distance between outermost parts of the seat	
2	Back support width: <i>(if different to seat width)</i>	Distance between outermost parts of back support. Including solid back support and thoracic support pads.	
3	Seat depth:	Distance between the front of the seat to the back support in the seat	
4	Seat surface height:	Height of seat above floor. Measure for front and rear.	
5	Footplate / foot support to seat:	Distance between footplate /support to seat base	
6	Footplate / foot support clearance from floor:	Height of the clear space between the lowest point of the foot support / footplates	
7	Back support height/ backrest upholstery:	Top of back support to seat base	
8	Back cane metal work height:	Top of back cane to seat base	
9	Armrest/ arm support height:	Top of armrest to seat base	

10	Armrest/ arm support length:	Back cane to the end of arm support
11	Overall length:	Consider this measurement for access and transport
12	Overall width	Consider this measurement for access and transport
A	Seat surface to back support angle:	To reflect the true seat to back support angle measure from the middle of the backrest surface to seat base
B	Leg rest to seat surface angle:	For most wheelchairs makes, "footrest hanger /front rigger angle" is calculated by 180° minus the leg rest to seat angle.
Arm support: <i>removable, flip up, desk, adjustable, single / dual mount</i>		Leg rest & hanger type: <i>60/70/80/90 degree, centre mount, elevation, fixed /swing away</i>
Rear wheels size and type:		Foot support type: <i>angle adjustment, ankle huggers, heel loops</i>
Casters size and type:		Head support and mounting:
Electronics: <i>Dynamics, Penny and Giles, Invacare Mk series, ASL, Quantum Rehab Q-Logic, Quickie® iQ™ s</i>		Others switches /modules: <i>Switches, attendant control, display units, ECU</i>
Input devices / controller: <i>Joystick, sip-n-puff, chin control, head arrays, mini / compact joystick – note mounting position and type.</i>		
Recline: <input type="checkbox"/> Yes <input type="checkbox"/> No Range: ° to °	Elevating Legrest: <input type="checkbox"/> Yes <input type="checkbox"/> No Range: ° to °	Tilt in space: <input type="checkbox"/> Yes <input type="checkbox"/> No Tilt range: ° to °
Other seating /mobility components /devices:		Issues identified / comments

POWER WHEELCHAIR AND SEATING SPECIFICATIONS			
ASSESSMENT FOR:		Funding:	DATE:
Cushion/seat base:	Size	Age / condition:	
Back support:	Size	Age / condition:	
Wheelchair:			
Power base type:			
Motor:			
Battery:			
Age:			
Condition:			
1	Seat width :		
2	Back support width: <i>(if different to seat width)</i>		
3	Seat depth:		
4	Seat surface height:	Front:	Rear:
5	Footplate / foot support to seat:		
6	Footplate / foot support clearance from floor:		
7	Back support height/ backrest upholstery:		
8	Back cane metal work height:		
9	Armrest/ arm support height:	Left	Right
10	Armrest/ arm support length:	Left	Right
11	Overall length:		
12	Overall width		
A	Seat surface to back support angle:	Degrees:	
B	Leg rest to seat surface angle:	Degrees:	
Arm support:		Leg rest & hanger type:	Foot support type:
Rear wheels size and type:		Casters size and type:	Head support and mounting:
Electronics:		Input devices / controller:	Others switches /modules:
Recline: <input type="checkbox"/> Yes <input type="checkbox"/> No Range: ° to °		Elevating Legrest: <input type="checkbox"/> Yes <input type="checkbox"/> No Range: ° to °	Tilt in space: <input type="checkbox"/> Yes <input type="checkbox"/> No Tilt range: ° to °
Other seating /mobility components /devices:		Issues identified / comments	

RESOURCES

Chapter 11, Appendix 4. B. *Therapeutic Support Surfaces Selection Tool*

Chapter 11, Appendix 4. C. *Reactive Support Surface Selection Tool*

Chapter 11, Appendix 4. D. *Active Support Surface Selection Tool*

Chapter 11, Appendix 5. *Perform a skin check prior to sitting at all times/Perform a skin check post sitting at all times*

Chapter 11, Appendix 6: *Levine Method For Wound Swab For Culture And Sensitivity*

Chapter 11. Appendix 7. *Mobilization Protocol After Flap Surgery*

Chapter 11. Appendix 8. A. *Physiotherapy Assessment Form*

Chapter 11. Appendix 8. B. *Pressure Management Assessment Tool*

Chapter 11. Appendix 8. C. *Seating Assessment, Winnipeg Health Sciences Centre*

Chapter 11. Appendix 8. D: *New South Wales State Spinal Cord Injury Service, Spinal Seating Professional Development Project*

TABLES

Introduction, Table 1: *RNAO levels of evidence*

Chapter 1, Table 1. *Pressure Ulcer Risk and Protective Factors in Chronic Spinal Cord Injury Stage*

Chapter 1, Table 2. *Risk Assessment Tools: Summary of Psychometric Properties*

Chapter 3. Table 1. *Differentiation of Iron-deficiency Anemia and Anemia of Chronic Disease*

Chapter 5, Table 1. *Overview of Bed Support Surfaces*

Chapter 9, Table 1. *Interdisciplinary Approach to Surgical Management of Pressure Ulcers in Individuals with Spinal Cord Injury*

Chapter 9, Table 2. *Complication, Reoperation, and Recurrence Rates after Surgical Pressure Ulcer Repair*

FIGURES

Chapter 2, Figure 1. *Visual skin check with mirror*

Chapter 2, Figure 2. *Common sites for pressure ulcers in a) prone, b) supine, c) side-lying and d) sitting*

Chapter 5, Figure 1. *Using hand to check areas of high pressure or bottoming out in supine position.*

Chapter 5, Figure 2. *Areas vulnerable to pressure damage in the supine position*

Chapter 5, Figure 3. *Elevating the heels with a wedge*

Chapter 5, Figure 4 *Protecting the heels using the end of the bed*

Chapter 5, Figure 5. *Recommended 30° side-lying position*

Chapter 5, Figure 6. *Areas vulnerable to pressure damage in the side lying position*

Chapter 5, Figure 7 *Areas vulnerable to pressure damage in prone position*

Chapter 5, Figure 8. *Recommended prone positioning*

Chapter 5, Figure 9. *Friction and shear with head of the bed elevated*

Chapter 5, Figure 10 *Areas vulnerable to pressure damage in sitting position*

Chapter 6, Figure 1. *Correct posture and postural changes seen in people with spinal cord injury*

Chapter 6, Figure 2. *Areas vulnerable to pressure damage in sitting position.*

Chapter 6, Figure 3. *Checking for bottoming out in sitting position.*

Chapter 7, Figure 1. *Transitional movements a) High sitting, b) Long sitting, c) Tailor sitting*

Chapter 7. Figure 2. *Transfers. Leg down lateral lift*

Chapter 7. Figure 3. *Transfer. Sliding board transfer*

Chapter 7. Figure 4. *Transfer. Standing pivot transfer*

Chapter 7. Figure 5. *Weight Shift. Push up using a) wheel and b) arm rest*

Chapter 7. Figure 6. *Weight Shift. Lateral shift using a) wheel and b) arm rest*

Chapter 7. Figure 7. *Weight Shift. Leaning forward*

Chapter 7. Figure 8. *Weight Shift. Leg lift*

Chapter 11, Appendix 1, Figure 1. *Relation between spinal cord segments, vertebral bodies, and spinal nerve roots.*

Chapter 11, Appendix 2, Figure 2. *Dermatomes: sensory innervation*

Chapter 11, Appendix 2, Figure 2. *Myotomes*

Summary of Recommendations

CHAPTER 1

Pressure ulcer prevention and the interprofessional team

1.1 Spinal cord injury interprofessional team (Page10)

Develop an interprofessional spinal cord injury team that includes, at a minimum, a physiatrist (or physician with spinal cord injury training), occupational therapist, physiotherapist, wound care clinician, nurse, psychologist, social worker, and dietitian. Include additional members as local resources allow. Ensure that all team members have knowledge of spinal cord injury and pressure ulcer prevention and care.

RECOMMENDATION LEVEL III

1.2: Rapid admission to specialized care (Page 11)

Admit people with spinal cord injury as soon as possible to a specialized spinal cord injury unit staffed by an experienced interprofessional team.

RECOMMENDATION LEVEL III

1.3: Community phase: outpatient services (Page12)

Provide adequate outpatient services where people with spinal cord injury who are living in the community can access an interprofessional team of clinicians with expertise in the management of individuals with spinal cord injury. Ensure that routine follow-up appointments provide preventive care to reduce secondary complications and improve quality of life.

RECOMMENDATION LEVEL III

1.4: Risk assessment tools (Page18)

Use the Waterlow Scale, the Braden Scale, or the Spinal Cord Injury Pressure Ulcer Scale (SCIPUS) tool to assess pressure ulcer risk in people with spinal cord injury.

RECOMMENDATION LEVEL IIA

1.5: Risk factor management (Page18)

Use the results of a comprehensive and systematic assessment of pressure ulcer risk factors to select and implement risk management strategies in individuals with spinal cord injury.

RECOMMENDATION LEVEL IV

1.6: Risk factor reassessment (Page18)

Reassess risk factors on a routine basis, as determined by the healthcare setting, institutional guidelines, and changes in the individual's health status.

RECOMMENDATION LEVEL IV

1.7: Assess deep tissue injury (Page20)

Consider ultrasound imaging of the tissue overlying the ischial tuberosity in suspected deep tissue injury.

RECOMMENDATION LEVEL III

CHAPTER 2

Human factors affecting pressure ulcer prevention

2.1: Prevention of skin damage (Page 26)

If skin irritation due to moisture develops or persists, pursue a consultation with a nurse with continence training for evaluation, topical treatment, and review of the bowel and bladder program.

RECOMMENDATION LEVEL III

2.2: Prevention during prehospital and acute care (Page 26)

As soon after spinal cord injury as emergency medical and spinal stabilization status allow, review individual risk factors and implement appropriate pressure ulcer prevention strategies that:

RECOMMENDATION LEVEL

- | | |
|--------------------------------------------------------|-----|
| ▪ Avoid prolonged immobilization whenever possible | lb |
| ▪ Limit the time a person is on a spinal board. | la |
| ▪ Employ intraoperative pressure reduction strategies. | llb |

2.3: Skin inspection (Page 27)

Conduct comprehensive daily visual and tactile skin inspections during rehabilitation and initial community reintegration, paying special attention to the areas that are most vulnerable to pressure ulcer development.

RECOMMENDATION LEVEL IV

2.4: Assess quality of life, pain, and depression (Page 30)

Assess the following as part of the comprehensive evaluation of people with spinal cord injury:

RECOMMENDATION LEVEL

- | | |
|-------------------|-----|
| ▪ Quality of life | IV |
| ▪ Pain | III |
| ▪ Depression | III |

Specific rating scales cannot yet be recommended.

2.5: Psychosocial interventions (Page 32)

Identify potential psychosocial factors that could increase the risk of pressure ulcers in people with spinal cord injury. Identify the psychosocial impact of pressure ulcers in people with spinal cord injury and pressure ulcers. Refer individuals to appropriate resources for problem resolution, including:

- Vocational rehabilitation services
- Peer counselling and support groups
- Formal psychotherapy/counselling and/or family therapy

RECOMMENDATION LEVEL IV

2.6: Ongoing structured education (Page 39)

Provide individuals who have spinal cord injury, their families, significant others, and healthcare professionals with structured education about effective strategies for the prevention and treatment of pressure ulcers. Be sure to deliver education at a grade 3 to 6 level using a variety of methods.

RECOMMENDATION LEVEL III

2.7: Individualize education (Page 39)

Provide education specific to the individual after each assessment and reassessment. This education should include:

- *Potential causes and risks of pressure ulcer development*
- *Methods of self-monitoring*
- *Reduction of pressure ulcer risks as part of the prevention plan*

RECOMMENDATION LEVEL III

2.8: Promote self-management (Page 41)

Promote self-management for people with spinal cord injury. Help them learn, consistently apply, and incorporate into their daily lives effective and appropriate pressure ulcer prevention strategies.

RECOMMENDATION LEVEL IV

CHAPTER 3

Body weight, nutrition, and hematologic and biochemical parameters of healing

3.1: Nutritional deficiency and dehydration (Page 51)

Consider nutritional deficiencies and dehydration as risk factors for pressure ulcer development in a person with spinal cord injury until these factors have been ruled out.

RECOMMENDATION LEVEL IV

3.2: Assessment by a registered dietitian (Page 51)

Ensure that a registered dietitian who is part of the interprofessional team caring for the person with spinal cord injury performs the nutrition assessment, determines and recommends the appropriate intervention, and assesses the outcome.

RECOMMENDATION LEVEL IV

3.3: Components of nutritional assessment (Page 52)

Assess nutritional status of all spinal cord–injured individuals who are at risk of developing a pressure ulcer, or present with a pressure ulcer on admission, with each change in condition and when the pressure ulcer is not healing at the expected rate. This assessment should include the following:

	RECOMMENDATION LEVEL
■ Anthropometric measurements	IV
■ Dietary intake and losses	IIb
■ Nutrition- and hydration-related blood work	III
■ Ability to self-feed or dependence on others for eating and drinking	IV
■ Other barriers to optimal food and fluid intake	IV

3.4: Serial weight measurement (Page 52)

Perform serial body weight measurements at least every 30 days to identify recent weight loss as an indicator of nutritional deficiency and pressure ulcer risk.

RECOMMENDATION LEVEL IV

3.5: Monitor hydration (Page 55)

Assess people with spinal cord injury for clinical signs and symptoms of dehydration.

RECOMMENDATION LEVEL IV

3.6: Nutritional intake and support (Page 56)

Implement early nutritional support measures if dietary intake is inadequate or if an individual is nutritionally compromised.

RECOMMENDATION LEVEL IV

3.7: Daily caloric intake (Page 56)

Provide 30 to 35 kcal/kg energy daily for people with pressure ulcers.

RECOMMENDATION LEVEL III

3.8: Daily protein intake (Page 57)

Provide 1.0 to 2.0 g/kg protein daily for people at risk of developing pressure ulcers.

Provide a daily protein intake at the higher end of the range for people with severe pressure ulcers.

RECOMMENDATION LEVEL IA

3.9: Provide adequate fluids (Page 57)

Estimate fluid requirements, based on 1 mL/kcal food consumed, and provide adequate fluids to maintain hydration.

RECOMMENDATION LEVEL IV

3.10: Arginine supplementation (Page 58)

Consider supplementing arginine to promote more rapid pressure ulcer healing if no contraindications exist.

RECOMMENDATION LEVEL III

3.11: Vitamin and mineral supplementation (Page 58)

Consider supplementing vitamins and minerals in people with known deficiencies to improve pressure ulcer healing. Use clinical judgment and the results of a thorough nutritional assessment to determine the need for nutrient supplementation in the absence of definitive tests for deficiencies.

RECOMMENDATION LEVEL IV

3.12: Vitamin E supplementation (Page 59)

Avoid vitamin E supplementation, as it may delay healing of pressure ulcers.

RECOMMENDATION LEVEL IV

3.13: Contraindications and precautions to supplementation (Page 60)

Identify all conditions that may be precautions or contraindications to supplementation, such as renal insufficiency, before implementing micronutrient, protein, or fluid supplementation.

RECOMMENDATION LEVEL IV

3.14: Enteral and total parenteral nutrition (Page 60)

Provide enteral nutrition to support pressure ulcer healing, if indicated, when the gastrointestinal tract is intact but dietary intake is inadequate and/or barriers to oral intake exist.

Provide total parenteral nutrition, if indicated, to people with pressure ulcer and gastrointestinal dysfunction or disease.

RECOMMENDATION LEVEL IV

3.15: Recommended blood work to help identify underlying barriers to healing (Page 61)

Screen for common conditions, such as anemia, inflammation, diabetes, and hypothyroidism, which are known to delay healing, to ensure appropriate treatment. Perform the following tests:

- *Complete blood count, including hemoglobin, hematocrit, white blood cell count, absolute lymphocyte count, and description of red blood cell morphology*
- *Iron profile, including ferritin, serum iron, percentage saturation, and total iron binding capacity*
- *Inflammatory markers: C-reactive protein and erythrocyte sedimentation rate*
- *Endocrine factors, including fasting or random blood glucose, hemoglobin A1C and thyroid function tests*

RECOMMENDATION LEVEL III

CHAPTER 4

Principles of pressure management

4.1: Assessment of pressure and other sources of external force (Page 70)

Ensure that occupational therapy and/or physiotherapy members of the interprofessional team, who have combined specialized training and experience working with people with spinal cord injury and in seating and positioning, perform a comprehensive pressure management assessment, in consultation with other interprofessional team members.

RECOMMENDATION LEVEL IV

4.2: 24-hour approach to pressure ulcer risk management (Page 70)

Perform a comprehensive assessment of posture and positioning to evaluate pressure ulcer risk. Consider all surfaces in both recumbent and sitting positions that a person uses to participate in daily activities over the entire 24-hour period.

RECOMMENDATION LEVEL IV

4.3: Pressure mapping (Page 75)

Use pressure mapping results in conjunction with clinical findings and the individual's preference to select appropriate support surfaces and to optimize the type and duration of position changes.

RECOMMENDATION LEVEL IV

4.4 Intervention: Pressure-redistribution strategies (Page 76)

Use a variety of pressure-redistribution strategies that are individualized to meet the person's needs and lifestyle. Provide timely and targeted education and reinforce effective pressure management strategies at every opportunity.

RECOMMENDATION LEVEL IV

4.5: Reassessment (Page 77)

Reassess pressure management using a 24-hour approach every 2 years, or more often if a pressure ulcer develops or there is a significant change in health status — including weight changes or functional ability — or if there are changes in living situation or a deterioration in the support surface/equipment.

RECOMMENDATION LEVEL IV

CHAPTER 5

Beds, mattresses, and recumbent positioning

5.1: Bed positioning (Page 87)

Ensure proper bed positioning by using devices and techniques that are appropriate for the type of support surface and mattress and the individual's health status.

- Use pillows, cushions, and positioning aids to:
 - » Bridge contacting tissues, including bony prominences
 - » Unload bony prominences
 - » Protect pressure ulcers and vulnerable areas of skin
- Do not use closed cut-outs in mattresses or donut-type cushions.

RECOMMENDATION LEVEL IV

5.2: Supine position (Page 88)

Use supine positioning to stretch and oppose sitting postures to maintain flexibility and skeletal alignment and reduce spasticity.

RECOMMENDATION LEVEL IV

5.3: Heel ulcers (Page 89)

Consider a universal prevention program to protect the heels of all people with spinal cord injury while supine or reclined, especially people undergoing surgical procedures.

RECOMMENDATION LEVEL IV

5.4: Side-lying position (Page 90)

Use a side-lying position at a 30° angle from supine that does not position the person directly on either hip.

RECOMMENDATION LEVEL IV

5.5: Prone position (Page 91)

Use prone positioning to stretch the hips and trunk while offloading the buttock region, including the ischial tuberosities, sacrum, and coccyx.

RECOMMENDATION LEVEL IV

5.6: Elevating the head of the bed (Page 92)

Avoid elevating the head of the bed above 30°. If raising the head of the bed is medically necessary, limit the amount of time in this position as much as possible.

RECOMMENDATION LEVEL IV

5.7: Sitting in bed (Page 93)

Avoid sitting in bed. Transfer the person to a sitting surface that is designed to distribute pressures properly in the seated position.

RECOMMENDATION LEVEL IV

5.8: Repositioning schedule (Page 94)

If the person's medical condition allows, turn and reposition individuals who require assistance at least every 2 hours, initially. Adjust the repositioning schedule based on the individual's skin response, determined by frequent skin checks, until an appropriate repositioning schedule is established.

RECOMMENDATION LEVEL IV

5.9: Repositioning techniques (Page 95)

Use repositioning techniques that prevent injury to the caregiver and reduce friction and shear of soft tissues when individuals are moved.

RECOMMENDATION LEVEL IV

5.10: Bed rest for pressure ulcer treatment (Page 96)

Avoid prolonged use of full-time bed rest to treat pressure ulcers in individuals with spinal cord injury. Use bed rest, if necessary, to offload pressure completely for a specific and limited time, such as after surgical repair of pressure ulcers.

RECOMMENDATION LEVEL IV

5.11: Sitting schedules for pressure ulcer treatment (Page 97)

Evaluate the individual's postural alignment, weight distribution, balance, stability, and pressure-redistributing capability to establish an appropriate sitting schedule.

RECOMMENDATION LEVEL IV

5.12: Support surfaces (Page 101)

Use a support surface with advanced pressure-redistributing properties, compared with a standard hospital foam mattress, to minimize peak pressure areas around bony prominences and protect soft tissue from bruising and injury.

RECOMMENDATION LEVEL IV

5.13: Reactive support surfaces (Page 101)

Select a reactive support surface for individuals who can be positioned without weight bearing on an ulcer and without bottoming out on the support surface.

RECOMMENDATION LEVEL IV

5.14: Active support surfaces (Page 101)

Select an active support surface if the individual cannot be positioned without pressure on an ulcer, when a reactive support surface bottoms out, if there is no evidence of ulcer healing or if new ulcers develop.

RECOMMENDATION LEVEL IV

5.15: Mattress Replacement (Page 101)

Replace the existing mattress with a support surface that provides better pressure redistribution, shear reduction and microclimate control in the following situations:

- *Pressure ulcers on multiple turning surfaces*
- *Compromised control of microclimate in the presence of deep tissue injury*
- *Person cannot be positioned off the ulcer*
- *They are a high risk of developing additional ulcers*
- *Failure to heal or wound deterioration*
- *Bottoms out on the existing support surface*

RECOMMENDATION LEVEL IV

5.16: Reassessment of support surfaces (Page 102)

Re-evaluate the suitability of the support surface for pressure ulcer prevention and treatment at least every 4 years, and sooner if the person's medical condition changes.

RECOMMENDATION LEVEL IV

5.17: Microclimate management (Page 103)

Select smooth, low-friction, breathable fabrics for bedding and clothing to optimize microclimate control and minimize friction.

RECOMMENDATION LEVEL IV

CHAPTER 6

Wheelchairs and other seating

6.1: Comprehensive seating assessment (Page 109)

Provide sitting support surfaces, such as wheelchairs and seating systems, based on the results of the comprehensive specialized interprofessional team assessment, according to individualized anthropometric, ergonomic, musculoskeletal, and functional principles and the individual's personal choices, lifestyle, and living environments.

RECOMMENDATION LEVEL IV

6.2: Principles of sitting posture and positioning for pressure management (Page 112)**RECOMMENDATION LEVEL**

- Address pelvic asymmetry, postural instability, kyphosis, and spasticity, using postural management and support surfaces. III
- Evaluate the effects of posture, deformity, and movement on interface pressure distribution and the influence of subdermal tissue loads on sitting support surfaces III
- Consider the effects of clothing, shoes, and additional layers on the surface's microclimate, friction, shear and pressure-redistributing properties. IV

6.3: Sitting support surfaces (Page 113)

Consider the characteristics and adjustability of the support surface to meet postural, functional, comfort, and pressure management needs.

RECOMMENDATION LEVEL IV

6.4: Trial equipment (Page 113)

Recommend support surfaces and equipment based on observations and client and caregiver feedback during the sitting simulation and trial.

Implement a trial of at least 24 hours and preferably several days to ensure the equipment both addresses pressure and microclimate issues and meets functional and lifestyle needs.

RECOMMENDATION LEVEL IV

6.5: Specialized seating clinics (Page 115)

When possible, use specialized seating clinics with an interprofessional team of clinicians who have expert training and experience working with people with spinal cord injury to assess and recommend wheelchairs and other sitting support surfaces.

RECOMMENDATION LEVEL IIA

6.6: Wheelchair prescription (Page 117)

Provide an individually prescribed wheelchair and pressure-redistributing seating system in collaboration with the person who will be using the equipment.

Ensure wheelchair configuration, postural supports, and sitting surfaces facilitate optimal wheelchair positioning and function.

RECOMMENDATION LEVEL IIA**6.7: Back support selection (Page 119)**

Select the back support in conjunction with the cushion. Choose a back support for trunk alignment and pelvic control to manage pressure, considering its impact on functional tasks and mobility of the trunk, shoulder girdle, and arms.

RECOMMENDATION LEVEL IV**6.8: Back support angle (Page 119)**

If the person tends toward a posterior pelvic tilt sitting posture, angle the back support to:

- *Support the posterior superior iliac spine or sacrum to increase pelvic stability and prevent gradual drift into more posterior pelvic tilt, which increases pressure on the coccyx and causes friction and shear*
- *Accommodate hip flexion limitations if the hip cannot be flexed to 90° to prevent the pelvis from sliding forward*
- *Accommodate hamstring tightness if not achieved through foot positioning*
- *Support the trunk over the pelvic base of support and strive for even pressure distribution across both buttocks*

RECOMMENDATION LEVEL IV**6.9: Wheelchair cushions (Page 120)**

Consider a variety of factors for comprehensive pressure management when selecting a wheelchair cushion:

- *Influence of cushion characteristics, including weight, on wheelchair performance*
- *Pressure-redistributing or -offloading characteristics at bony areas*
- *Positioning capabilities for postural management in resting and dynamic positions*
- *Maintenance of a supported and symmetrical resting posture to prevent postural deterioration over time*
- *Adequate stability for function and prevention of long-term postural deterioration*
- *Microclimate management*
- *Shear and friction reduction at the user-cushion interface*
- *Comfort*

RECOMMENDATION LEVEL III**6.10: Cushion maintenance (Page 120)**

Teach the individual with spinal cord injury and the caregiver to:

- *Care for and maintain the wheelchair cushion*
- *Monitor the cushion for signs of wear at an appropriate frequency*
- *Set up the cushion properly, including orientation and monitoring for bottoming out*
- *Replace the cushion if it is deteriorating*
- *Avoid placing additional layers on top of the cushion unless deemed essential*

RECOMMENDATION LEVEL IV**6.11: Dynamic weight-shifting (Page 122)**

Consider power weight-shifting technology when other methods, such as active pressure redistribution or pressure redistribution through functional movements, are not effective or not possible.

RECOMMENDATION LEVEL IV

6.12: Power weight-shifting and pressure management (Page 123)

Encourage use of power weight-shifting technology, such as tilt, recline, and stand, frequently throughout the day to reduce the effects of sitting pressure on bony prominences of the buttocks.

Individualize these strategies for each person using pressure mapping, palpation, and skin response. Start with a position change that can be maintained for 2 minutes, at least once every 15 minutes.

RECOMMENDATION LEVEL IV**6.13: Power tilt (Page 123)**

Add full tilt gradually where possible to increase blood flow over the ischial tuberosities. A minimum of 30° tilt is required to adequately redistribute pressure and increase blood flow.

RECOMMENDATION LEVEL IIA**6.14: Other sitting surfaces (Page 124)**

Assess and prescribe options for other seating needs and provide recommendations for transfers and repositioning as part of the seating assessment to ensure that these surfaces and their use do not cause pressure ulcers. These needs may include:

- *Bathroom surfaces, such as a commode, toilet, shower bench, or other surface*
- *Seating options for travel*
- *Sports wheelchairs and seating for recreational and other activities*
- *Any other surface the person may use other than the wheelchair*

RECOMMENDATION LEVEL IV**6.15: Bowel routine (Page 124)**

Consider using a pressure-redistributing surface on the commode or toilet to minimize pressure ulcer risk.

Optimize the bowel care routine to minimize time using the commode, and reassess the bowel program if more than 1 hour is required.

Consider a tilt commode if postural instability results in sliding or uneven pressure distribution on the sitting surface.

Consider customized surfaces if necessary.

RECOMMENDATION LEVEL IV**6.16: Equipment options for travel (Page 126)**

Advise the individual with spinal cord injury about equipment options and appropriate preventive strategies during travel. Educate the person and provide written information to minimize the risk of a pressure ulcer during travel.

RECOMMENDATION LEVEL IV**6.17: Education about the need for regular reassessment (Page 127)**

Educate the individual with spinal cord injury to monitor the condition of seating equipment and support surfaces regularly to ensure the equipment remains effective for pressure management.

RECOMMENDATION LEVEL IV**6.18: Schedule for periodic reassessment (Page 127)**

Establish a mechanism for regular reassessment of performance of sitting support surfaces specific to pressure ulcer prevention and treatment. Schedule reassessment at least every 2 years, or sooner if any of the following occurs:

- *Health status changes, including weight or medical changes*
- *Changes in functional status*
- *Equipment wear or disrepair*
- *Pressure ulcer development*
- *Changes in living situation*

RECOMMENDATION LEVEL IV

6.19: Replacement of pressure management equipment (Page 127)

Replace seating equipment and support surfaces according to manufacturer's recommendations, or sooner if equipment demonstrates any signs of deterioration, including but not limited to wear, cracking, and allowing bottoming out.

RECOMMENDATION LEVEL IV

CHAPTER 7

Mobility, activity, and conditioning

7.1: Mobility assessment (Page 134)

Ensure that a skilled therapist who is part of the interprofessional spinal cord injury team performs a comprehensive assessment of mobility, including evaluation of physical impairments, gross motor skills, and movement quality.

RECOMMENDATION LEVEL IV

7.2: Pressure ulcer risks associated with mobility and activity (135)

Evaluate pressure ulcer risks associated with movement during the mobility assessment, including the following:

- *Adequacy of postural support in all positions to reduce the risk of shear due to sliding*
- *Protection of vulnerable bony prominences from trauma at rest and during movement*
- *Amount of lift off different surfaces achieved by the individual during movement to minimize friction*
- *Safety of environmental configuration to minimize the risk of trauma and falls, including maintaining all transfer surface heights as equal as possible*
- *Level of attention the individual gives to movement quality*
- *Identification of factors that interfere with movement quality or safety*

RECOMMENDATION LEVEL IV

7.3: Reassessment (Page 136)

Reassess gross motor skills abilities and current pressure management strategies if gross motor function declines or a pressure ulcer develops.

RECOMMENDATION LEVEL IV

7.4: Gross motor skills training (Page 136)

Include gross motor skills-specific training in the plan of care for bed mobility, transfers, wheelchair mobility, and ambulation, as appropriate.

RECOMMENDATION LEVEL IV

7.5: Pressure management and bed mobility (Page 137)

Optimize independent bed mobility skills and encourage the person with spinal cord injury to change positions regularly throughout the day to offload and redistribute pressure.

Consider training for bed mobility skills through the long-sitting position for individuals who cannot perform active pelvic and leg adjustments.

RECOMMENDATION LEVEL IV

7.6: Transfers (Page 138)

Select and train transfer techniques to all surfaces necessary for daily activities to ensure safe repositioning and minimize skin and tissue damage during movement.

Teach transfers to all surfaces necessary for daily activities, as risks and abilities are context dependent.

Consider alternative transfers if commonly used transfers cannot adequately support independence and pressure ulcer prevention.

RECOMMENDATION LEVEL IV**7.7: Wheelchair skills (Page 140)**

Integrate controlled simulations into a formalized wheelchair skills training program.

RECOMMENDATION LEVEL IB**7.8: Individualizing weight-shift strategies (Page 141)**

Individualize pressure-redistributing strategies using a variety of weight-shifting approaches including automatic pressure redistribution with functional movement, active lifting or shifting, and dynamic weight shifts (tilt and recline) with and without power-assist.

Base the duration, frequency, and amount of active or power-assisted weight-shifting on the individual skin response and the effectiveness of the strategy across the full day.

RECOMMENDATION LEVEL III**7.9: Evaluating pressure-redistributing movements (Page 141)**

Use manual palpation, observation, and pressure mapping, as appropriate, to evaluate the effectiveness of weight-shifting strategies.

Incorporate information about effective use of weight-shifting strategies, including demonstrations, into the individual's pressure management plan.

RECOMMENDATION LEVEL IV**7.10: Automatic pressure redistribution with functional movements (Page 141)**

Ensure that an individual who does not use active or dynamic intentional weight shifts to redistribute pressure performs more frequent skin checks if activities or daily routines change.

Balance the benefits of frequent functional movements performed throughout the day while in the wheelchair with the potential risk of injury due to friction and shear.

RECOMMENDATION LEVEL IV**7.11: Active weight shifting: leaning forward and to the side (Page 142)**

Encourage leaning forward or to the side, as this produces more complete and prolonged pressure reductions than lifting vertically.

Educate people with spinal cord injury about the risks and benefits of active weight-shifting (intentional pressure redistribution) techniques. Work with the individual to select a technique (lifting or leaning) and frequency that best meets that person's needs.

RECOMMENDATION LEVEL IV**7.12: Standing (Page 145)**

Consider individual risks of standing and encourage appropriate individuals to stand with a support, such as a standing frame or alternative device.

RECOMMENDATION LEVEL III

7.13: Walking (Page 145)

Encourage walking in appropriate individuals where appropriate footwear and leg support can be provided.

RECOMMENDATION LEVEL III

7.14: Exercise for pressure ulcer prevention (Page 146)

Encourage the person with spinal cord injury to participate in regular exercise that is consistent with Canadian physical activity guidelines to optimize muscle strength and endurance, encourage postural alignment, improve cardiovascular endurance, and prevent fatigue and deconditioning.

RECOMMENDATION LEVEL III

7.15: Maintenance of range of motion and flexibility (Page 146)

Use active or active-assisted movements to maintain joint range of motion and muscle flexibility, when possible.
Use conventional passive range-of-motion programs for individuals without motor function.

RECOMMENDATION LEVEL IV

7.16: Functional activities (Page 147)

Integrate daily exercise routines into functional activities to support recovery and maintain physical and functional abilities.

RECOMMENDATION LEVEL IV

7.17: Electrical stimulation (Page 147)

Consider the use of electrical stimulation to decrease ischial pressure and increase blood flow to tissues.

RECOMMENDATION LEVEL IIA

CHAPTER 8

Assessment after development of a pressure ulcer

8.1: Interprofessional team assessment of the individual (Page 153)

Ensure that the interprofessional spinal cord injury team performs a prompt, comprehensive evaluation of a person with spinal cord injury who develops a pressure ulcer, including the following:

- *Investigate underlying medical conditions*
- *Identify recent changes in physical or mental status*
- *Evaluate nutritional status*
- *Evaluate microclimate management*
- *Assess all support surfaces, lifts, and transfers*
- *Review pressure redistribution strategies, repositioning schedules, and skin checks*
- *Review posture and positioning in sitting and recumbency to identify changes and needs*
- *Review current preventive strategies*

RECOMMENDATION LEVEL IB

8.2: Assessing the pressure ulcer (Page 155)

Use a validated tool to assess the pressure ulcer, including the wound base, edges, and periwound skin.

RECOMMENDATION LEVEL IB

8.3: Identify infection (Page 156)

Evaluate the pressure ulcer for clinical signs of superficial or deep infection.

Investigate for bone infection if infection persists or the wound fails to progress in the expected time frame.

RECOMMENDATION LEVEL III

8.4: Pressure ulcer monitoring (Page 158)

Monitor and assess the pressure ulcer consistently and regularly to determine the adequacy of the plan of care:

Monitor the pressure ulcer at each dressing change.

Review and document pressure ulcer status at least monthly and every time the condition of the pressure ulcer or the individual changes.

Consider individual factors when evaluating the healing rate of pressure ulcers.

RECOMMENDATION LEVEL IV

8.5: Objective assessment of healing (Page 158)

Evaluate the progress of healing using an instrument or quantitative measure that has been shown responsive to change in wound status, such as acetate tracing, the Photographic Wound Assessment Tool (PWAT) or the Pressure Ulcer Scale for Healing (PUSH).

RECOMMENDATION LEVEL IB

8.6: Regular reassessment (Page 158)

Assess people who have experienced a pressure ulcer, through the interprofessional spinal cord injury team, every 12 to 24 months to evaluate posture, positioning, pressure redistribution strategies, microclimate factors (temperature and moisture), and equipment. Follow people experiencing continuing difficulties more frequently.

RECOMMENDATION LEVEL IV

CHAPTER 9

Pressure ulcer treatment

9.1: Interprofessional team for pressure ulcer treatment (Page 163)

Ensure timely referral to the interprofessional spinal cord injury team in treating pressure ulcers in this population.

RECOMMENDATION LEVEL IV

9.2: Sitting schedules for pressure ulcer treatment (Page 166)

Evaluate the individual's postural alignment, weight distribution, balance, stability, and pressure-redistributing capability to establish an appropriate sitting schedule.

RECOMMENDATION LEVEL IV

9.3: Beds and mattresses (Page 166)

Consider replacing the recumbent support surface with one that provides better pressure redistribution, offloading capabilities, shear reduction, and microclimate control for individuals who:

Cannot be positioned off the ulcer

- *Have pressure ulcers on at least two turning surfaces*
- *Fail to heal or demonstrate ulcer deterioration despite appropriate comprehensive care*
- *Have a high risk of developing additional ulcers*
- *Bottom out on the existing support surface*

RECOMMENDATION LEVEL IV

9.4: Assess support surfaces for treatment (Page 167)

Assess the suitability of existing sitting support surfaces for treatment in a person with a pressure ulcer.

Evaluate the current sitting surface or cushion to determine if an alternative choice would better meet the person's needs during treatment of the ulcer.

RECOMMENDATION LEVEL IV**9.5 Dressings (Page 169)**

Select a dressing(s) that provides the optimal moisture level to the wound base of superficial pressures ulcers.

Ensure the dressing meets the needs of the individual and is modified as individual goals and/or wound status change.

Avoid using daily dressing changes if at all possible by using absorbent dressings that manage exudate and odour and remain in place for as long as possible.

RECOMMENDATION LEVEL IB**9.6: Consider antimicrobial dressings (Page 170)**

Consider the use of antimicrobial dressings if signs of infection are present.

RECOMMENDATION LEVEL IV**9.7: Electrical stimulation to speed closure of pressure ulcers (Page 170)**

Use electrical stimulation combined with standard wound care interventions to promote closure of stage III or IV pressure ulcers.

RECOMMENDATION LEVEL IA**9.8: Other adjunctive therapies for nonsurgical treatment of pressure ulcers (Page 171)**

Consider adding the following adjunctive therapies to a standard wound care program to speed healing of stage II, III, or IV pressure ulcers.

	RECOMMENDATION LEVEL
▪ Electromagnetic energy	Ib
▪ Ultraviolet-C light	Ib
▪ Noncontact nonthermal acoustic therapy	III
▪ Topical oxygen	III
▪ Maggot therapy	III
▪ Topical recombinant growth factors	III
▪ Recombinant erythropoietin	III
▪ Anabolic steroids	III
▪ Activated factor XIII	III
▪ Tension therapy	IV
▪ Hyperbaric oxygen	IV

9.9: Preoperative evaluation (Page 175)

Assemble an interprofessional team to ensure optimal management of the person and the ulcer before, during, and after surgery, including:

- *Selecting appropriate surgical candidates*
- *Performing a comprehensive assessment*
- *Implementing appropriate preoperative management*
- *Selecting the best surgical option and implementing it with expertise*
- *Planning and implementing optimal postoperative care*

RECOMMENDATION LEVEL IV

9.10: Surgical referral (Page 175)

Refer appropriate individuals with complex, deep, stage III pressure ulcers, which may include ulcers with undermining or sinus tracts, and those with stage IV pressure ulcers for surgical evaluation.

RECOMMENDATION LEVEL IIA

9.11: Negative pressure wound therapy (Page 177)

Consider the utility of negative pressure wound therapy in preparing pressure ulcers for surgical closure.

RECOMMENDATION LEVEL III

9.12: Nutrition (Page 177)

Involve a registered dietitian to assess nutritional status and correct preoperatively nutritional imbalances that are anticipated to have a significant effect on the success of surgical repair.

RECOMMENDATION LEVEL III

9.13: Surgical pressure ulcer management (Page 180)

Follow these tenets of surgical treatment when surgery is indicated:

- *Debriding the wound, including excising the ulcer, surrounding scar, bursa, soft tissue calcification, and underlying necrotic or infected bone, possibly using dye-assisted debridement*
- *Filling dead space*
- *Enhancing the vascularity of the healing wound*
- *Redistributing pressure off the bone*
- *Resurfacing with a large regional pedicle flap, with the suture line away from the area of direct pressure and from adjacent flap territories, preserving options for potential future repairs*

RECOMMENDATION LEVEL IIA

9.14: Flap selection (Page 181)

Consider the location of the wound, potential flaps, and optimal location-specific techniques for reconstruction when determining the surgical technique for a specific ulcer repair procedure.

RECOMMENDATION LEVEL IIB

9.15: Amputation and salvage surgery (Page 184)

Perform amputation when pressure ulcers have proven refractory to surgery, to manage spasticity associated with chronic ulceration, or to remove a flail limb.

Perform salvage surgery in situations where it is lifesaving.

RECOMMENDATION LEVEL III

9.16: Postoperative management (Page 185)

Know and implement appropriate postoperative care after all pressure ulcer surgical repair:

- *Assess and manage pain.*
- *Evaluate support surfaces.*
- *Position the individual to keep pressure off the surgical site.*
- *Consider using an active bed surface when pressure on the surgical flap is unavoidable.*
- *Arrange a seating and postural assessment at the appropriate time during the postoperative mobilization period.*
- *Progressively and gradually mobilize the individual to a sitting position over at least 4 to 8 weeks to prevent re-injury of the ulcer or surgical site.*
- *Provide education on pressure management and skin inspection.*

RECOMMENDATION LEVEL IV

9.17: Identify complications (Page 185)

Identify, prevent, and manage potential complications of surgical intervention on an individual basis, including:

Hemorrhage

Wound dehiscence or wound separation

Delayed infection and abscess

Hematoma and seroma

Recurrence

RECOMMENDATION LEVEL IIB

CHAPTER 10

Telerehabilitation

10.1: Telerehabilitation (Page 193)

Consider telerehabilitation as a potentially useful approach for prevention and management of pressure ulcers in people with spinal cord injury.

RECOMMENDATION LEVEL IV